

## AN *IN SITU* DEVICE FOR SENSING AND COLLECTING MICROPLANKTON

EDWARD D. SCURA<sup>1</sup>

National Oceanic and Atmospheric Administration  
National Marine Fisheries Service  
Southwest Fisheries Center  
La Jolla, California 92038

### ABSTRACT

This report describes a simple system that was developed to search for and collect "patches" of microzooplankton at sea. It consists of a shipboard diaphragm pump, 50 meters of vacuum hose, and an *in situ* particle sensor attached to the influent end of the hose. This system was used to collect water at discrete depths while the particle concentration of the water was continuously monitored as it entered the pump hose.

Laboratory tests showed no significant avoidance by live microzooplankton of the particle sensor or the collecting device. There appeared to be no difference in the mortalities of organisms that were pumped through the system compared with those that did not pass through the system. In addition, laboratory tests indicate that small, high-density patches of microzooplankton can be collected with minimal smearing of the sample.

The device was tested in several sea trials off the southern California coast, in the New York Bight, and in the Austnesfjorden near Lofoten, Norway. In Austnesfjorden, a water sample was collected that contained 0.6 micronauplii/ml. This is believed to be the highest concentration of micronauplii ever collected.

### RESUMEN

En este trabajo se describe un mecanismo sencillo, ideado para encontrar y recolectar en el mar, concentraciones de micro-zooplancton. Se utiliza a bordo una bomba de diafragma con 50 metros de tubo de vacío y un sensor de partículas *in situ* adaptado a la extremidad del tubo. Este sistema fue usado para recoger agua a ciertas profundidades, controlando continuamente las partículas que entraban con el agua.

Los análisis en el laboratorio no indicaron que los integrantes vivos del micro-zooplancton escapasen al sensor de partículas o al dispositivo de recolección. No se observó diferencia en la mortalidad de organismos obtenidos mediante este sistema y los que no sufrieron la acción del mismo. Los análisis de laboratorio indican además, que los organismos ex-

perimentan una fricción mínima al ser obtenidos de pequeñas zonas en el mar donde aparecían con densidad de población elevada.

El dispositivo mencionado se probó repetidas veces en el mar, cerca de la costa sur de California, en la bahía de Nueva York y en Austnesfjorden cerca de Lofoten (Noruega). En Austnesfjorden se tomaron muestras de agua que contenían 0.6 micro-nauplios por ml., y se considera que esta concentración es la máxima obtenida hasta la fecha.

### INTRODUCTION

Although it is widely recognized that the distribution of marine plankton is not random (Boyd 1973), little is known about the microstructure of the upper mixed layer because of the limitations of conventional collecting devices. Plankton nets sample large volumes of water and therefore lack the resolution necessary to detect the small-scale structure of planktonic communities. Fisheries biologists, in particular, need to study the microdistribution of marine plankton because of an apparent contradiction in many investigations of larval fish survival at sea. Several laboratory studies with pelagic fish larvae indicate that the concentration of appropriate food organisms required for moderate growth and survival is generally higher than the density of analogous organisms found in the spawning grounds (May 1974). Most observers agree that this discrepancy results from the inadequacies of conventional plankton-sampling schemes; that is, although plankton nets give mean densities of plankton in a scale of thousands of cubic meters, this information can be misleading because microzooplankton densities can vary by more than 2 or 3 times in a scale of less than a meter (Owen 1981). Since the searching volume of a fish larva is generally less than 100 liters per day (Blaxter 1966; Rosenthal and Hempel 1970; Hunter 1972) it is obvious that a description of plankton distribution on the meter scale or less is necessary to understand the feeding dynamics of fish larvae.

Recently developed *in situ* particle counters can detect the number and sizes of individual plankters with spatial resolution in the scale of centimeters (Boyd and Johnson 1969; Maddux and Kanwisher 1965). Although these instruments are useful for studying the microstructure of planktonic com-

<sup>1</sup>Present Address:  
Aquatic Farms Ltd.  
49-139 Kamehameha Highway  
Kaneohe, Hawaii 96744

[Manuscript received January 29, 1982.]

munities, they do not collect discrete samples of monitored water. I found this to be a serious limitation for my work on larval fish survival at sea. Fish larvae are selective predators, and feeding success depends on a number of factors including the type, density, and size of the prey (Lasker 1975; Scura and Jerde 1977). Also the food selected by fish larvae can differ in nutritional value (Lasker et al. 1970; Scura and Jerde 1977). To study these relationships and their effect on larval survival one must collect discrete samples of seawater from various locations within the spawning grounds so that the densities, size frequency distributions, and species of the prey can be determined.

If seawater samples can be collected without injuring the prey or altering their concentration, then feeding experiments can be conducted by introducing laboratory-produced fish larvae into the seawater samples. This technique can be used to determine feeding thresholds and prey preferences of fish larvae at various developmental stages.

Lasker (1975) established feeding criteria for first-feeding anchovy larvae (*Engraulis mordax*) in waters collected from the chlorophyll maximum layers off the southern California coast. He used an *in situ* pump in conjunction with a shipboard fluorometer to find aggregations of the naked dinoflagellate *Gymnodinium splendens* that were rich enough to initiate feeding in early post-yolk-sac anchovy larvae. Although *G. splendens* is a good food for first-feeding anchovy larvae, older larvae require larger particles (e.g., copepod nauplii) to meet their energy needs (Hunter 1972). Lasker was unable to find aggregations of microzooplankton rich enough to support substantial feeding by anchovy larvae because his fluorometric technique was only useful for detecting phytoplankton. Although zooplankton may aggregate in or near chlorophyll maxima (Mullin and Brooks 1972), Lasker had no way of monitoring zooplankton concentrations other than by random discrete sampling, which was found to be ineffective.

In this report I describe a simple system to search for and collect "patches" of microzooplankton. It consists of a shipboard diaphragm pump that samples water from discrete depths and a particle sensor that continuously monitors the particle concentration of the water as it enters the pump hose.

This system has been used in several sea trials off the southern California coast, in the New York Bight, and in the Austnesfjorden in the Lofoten area of Norway.

## DESCRIPTION OF THE DEVICE

The system for sensing and collecting microplankton is made up of two components: (1) a ship-

board diaphragm pump (Jabsco Model #34600) capable of pumping 25 to 30 liters of water per minute through 50 meters of 2.5-cm. I.D. vacuum hose (Gemline light duty) and (2) a particle-detecting system that consists of an *in situ* continuous-flow particle sensor that independently samples water from a point adjacent to the influent end of the pump hose. The particle sensor is connected to a shipboard Coulter Counter Model A by a shielded cable, which is taped along the length of the pump hose. The Model A was modified by connecting an integrator buffer gain control as illustrated in the circuit diagram in Figure 1. The output from the integrator connects to a multiple-voltage range recorder. The impulses from the particle sensor are integrated so that increases in counting rate (i.e., higher particle concentration) deflect the recorder pen from the baseline. The response is proportional to the counting rate, so knowledge of the flow rate through the particle sensor can be used to calibrate the instrument to give the concentration of particles in the water. However, I did not rely on the instrument for precise particle counts because of the possibility of erroneous counts due to electrical interference, air bubbles, or nonliving particles. This instrument was designed as a searching and collecting device. If the detector response indicated a region with high particle concentration, it was easy to collect the water from the pump effluent for detailed shipboard examination with either a microscope or a Coulter Counter Model T<sub>A</sub>, or for preservation for later laboratory analysis.

The particle sensor operates on the Coulter Counter principle. Seawater passes through a 3-mm tube containing two electrodes separated by a 1-mm aperture (Figure 2). The seawater acts as the electrolyte, and a current is induced between the electrodes. As a particle passes through the aperture, the resistance between the electrodes is changed proportionally to the volume and impedance of the particle.

The particle sensor was machined from a 1.9-cm-diameter solid Lexan rod (Figure 2). The electrodes consisted of 2-cm squares of platinum foil that were welded to the leads from the shielded cable. Prior to welding, the leads were passed through the electrode component and out the particle sensor end of the 3-mm passage by way of a small hole drilled in the side of the electrode component (Figure 2). After welding, the foil was rolled into a cylinder and fitted into the 3-mm passage of the electrode component by pulling back on the lead from the shielded cable. The length of exposed lead from the shielded cable to the electrode component was then imbedded in a flexible urethane resin to insulate against electrical leakage. The electrode components were removable so that the sensor could be disassembled in case the aperture became

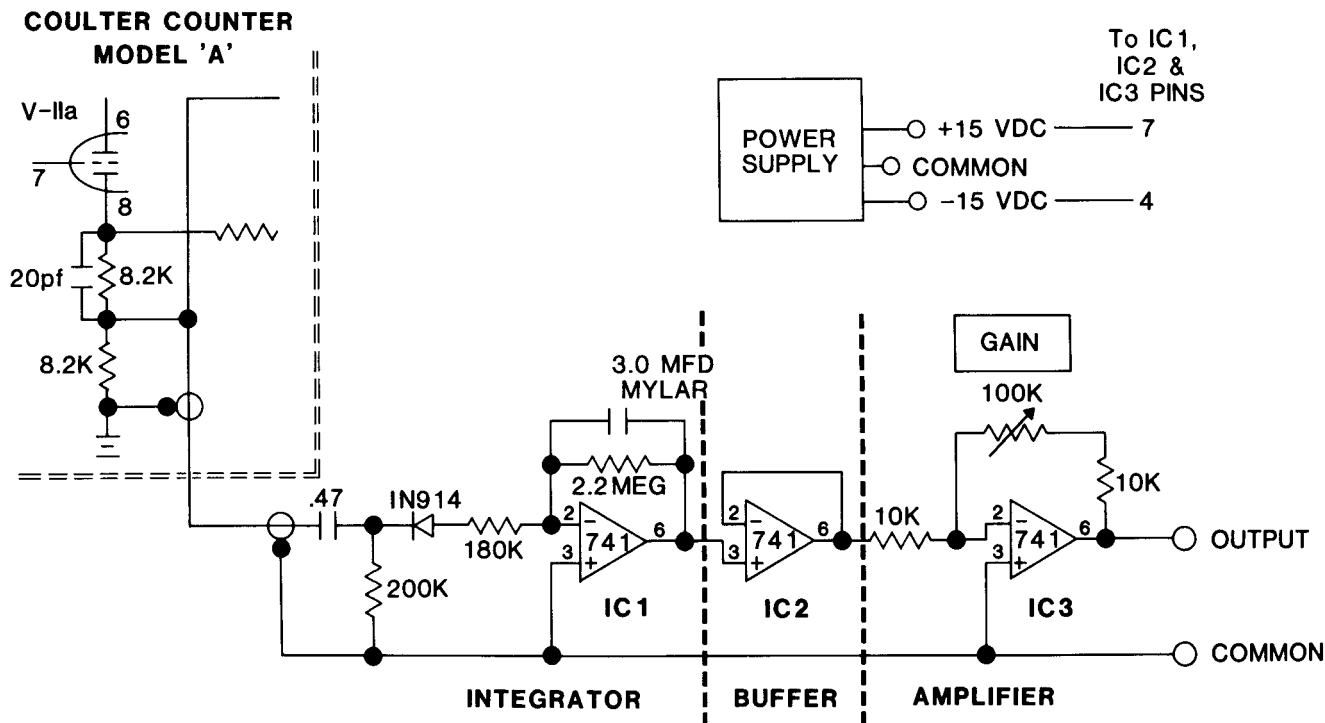

Figure 1. Circuit diagram for modified Coulter Counter Model A particle counter.

clogged (something that has not happened during 45 days of sea trial).

Water is pumped through the sensor at a rate of  $200 \pm 10$  ml/minute by a vacuum created from connecting the effluent end of the particle sensor to the intake of the pump hose as illustrated in Figure 3. This connection was made with a 2-M-by-3-mm I.D. tygon tube to insure that the electrical resistance through the aperture between the electrodes is much less than by any

other route. For the same reason, the intake for the particle detector was connected to a 30-cm-by-3-mm I.D. tygon tube. The connections between electrodes and the shielded cable (that transmitted the signal to the ship) were imbedded in a flexible urethane resin to insulate against electrical leakage.

### OPERATION

To operate the system, the sample probe, which consists of the influent end of the pump hose with attached particle sensor, is attached to a weighted (20 kilos) hydrowire and slowly lowered through the water column with the pump and the particle detector in operation. Depths are taken from the winch-metering device and called out to the operator, who records them on the chart paper adjacent to the corresponding response on the recorder. Using this technique, it is possible to get a vertical profile of the particle distribution to a depth of 35 m. Longer lengths of hose could be used to study the particle distribution to greater depths, but it was not needed for our work.

The detector responds to the particle concentration in the water within 2 seconds after the water enters the pump hose; it takes 60 seconds for the water to pass through the hose to the deck of the ship. It is therefore a simple matter for the operator to collect a discrete water sample at the effluent end of the pump system 58 seconds after observing an interesting response on the recorder. Occasionally particle sizes overlap,

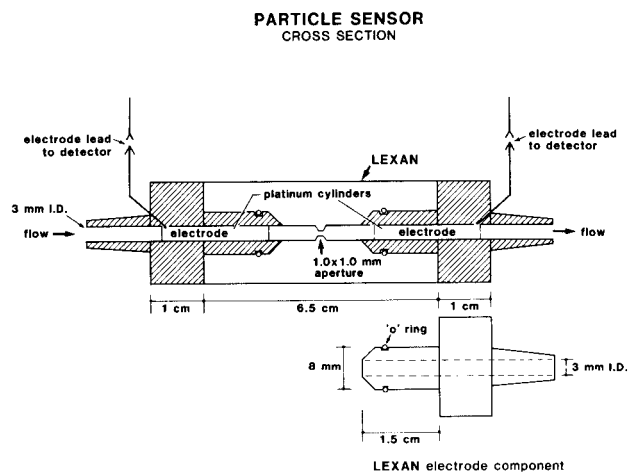

30 cm x 3 mm I.D. tube connected to inlet  
 2 M x 3 mm I.D. tube connected to effluent

Figure 2. Particle sensor.

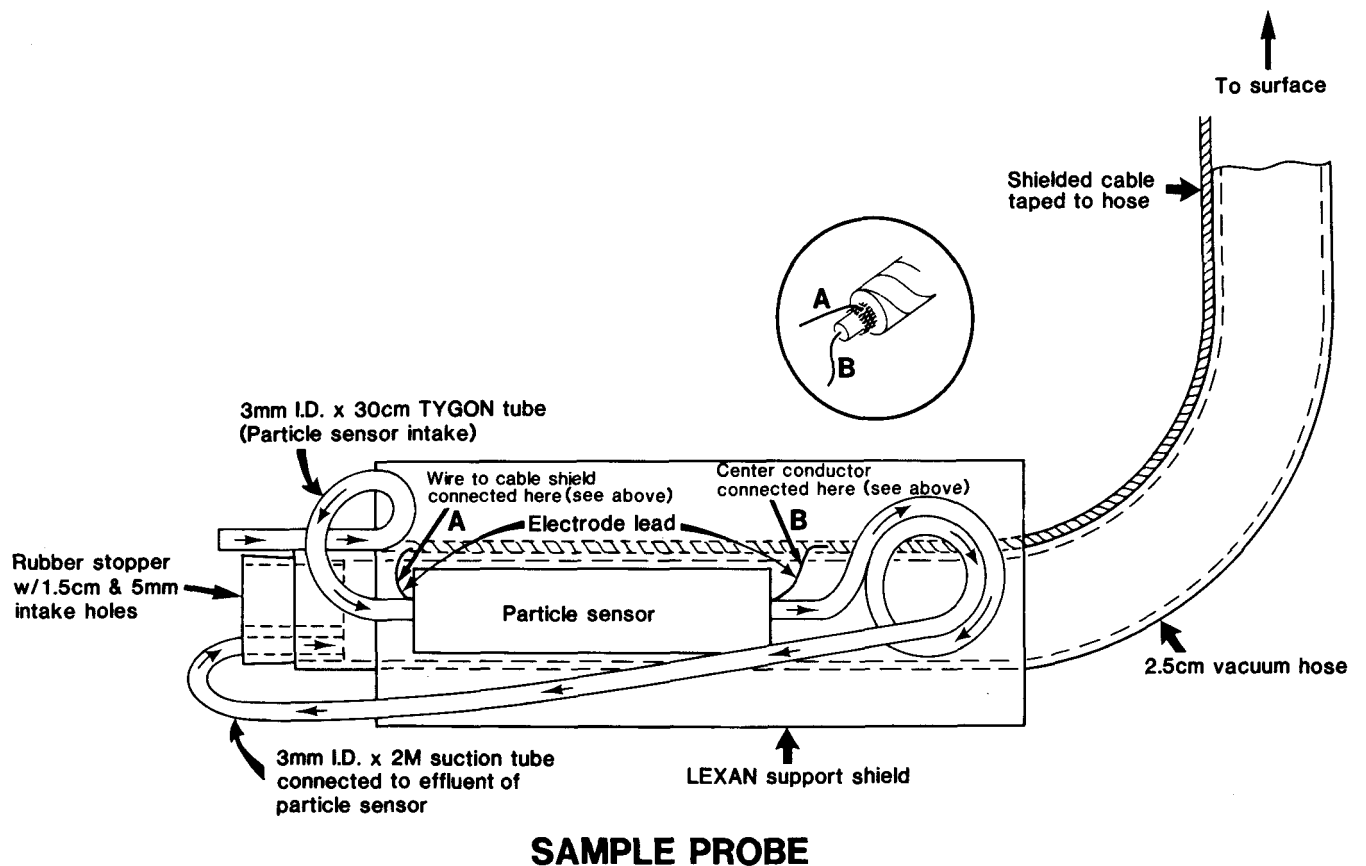

Figure 3.

making it difficult to detect the smaller microneuplii. Such is the case when the concentration of larger phytoplankton (e.g., *Ceratium sp.*) is sufficiently high to mask the presence of the less-concentrated microzooplankton. Careful manipulation of the instrument's threshold adjustment is important at such times.

The particle sensor operates on direct current so that the polarity of the electrodes must be reversed approximately every minute to prevent a change in sensitivity due to plating of the electrodes. This is easily accomplished on the Coulter Counter Model A by tripping the reset switch.

### PERFORMANCE

With any plankton-collecting device, there is always the question of avoidance. This system has two separate components that sample plankton. One is the diaphragm pump, which samples at a rate of 25 to 30 l/min through a 1.5-cm orifice; the other is the particle sensor, which samples at a rate of 90 to 210 ml/min through a 3-mm orifice. Although larger zooplankters are likely to avoid such slow influent currents, this system was designed to collect microzooplankton

smaller than 600  $\mu\text{m}$ . To test for this, wild plankton were collected off La Jolla, California, in a 42- $\mu\text{m}$  plankton net.

Back in the laboratory, the plankton were filtered through a 560- $\mu\text{m}$  screen and collected on a 64- $\mu\text{m}$  screen. The plankton were allowed to settle for 2 hours to eliminate those killed by handling. Then they were added to a tank containing 400 liters of filtered seawater to make a final concentration of  $0.8 \pm 0.3$  organisms/ml ( $\pm 2$  S.D.). This concentration was chosen because it is within the range that might be expected in a plankton patch at sea. The particle-pumping system was started in a separate tank containing filtered seawater, and once normal pumping was established, the sample probe was transferred into the tank containing the microplankton. Pumping was resumed for 2 minutes, and after 70 seconds, six 1-liter samples were collected and the plankton concentration determined. If plankton in the 64 to 560- $\mu\text{m}$  size range are capable of avoiding the influent current of the particle-pumping system, then the concentration of particles in the pumped water should have been less than in the tank. The mean  $\pm 2$  S.D. for the pumped samples was  $0.7 \pm 0.3$  organisms/ml, which was not

significantly different from the water in the tank (0.8 organisms/ml).

To test for microzooplankton's avoidance of the particle sensor, a 3-mm I.D. tube was connected to a peristaltic pump set at a flow rate of 200 ml/min. The influent end of the tube was placed in a 4-liter beaker filled with seawater containing microzooplankton (64-560  $\mu\text{m}$ ) at a concentration of  $1.5 \pm 0.4$  organisms/ml ( $\pm 2$  S.D.). Four 10-ml samples were collected over a 2-minute period, and the particle concentration was determined. The mean  $\pm 2$  S.D. for the pumped water was  $1.7 \pm 0.6$  organisms/ml. This test was repeated with seawater containing  $0.5 \pm 0.2$  organisms/ml, and the pumped water contained  $0.5 \pm 0.1$  organisms/ml.

### INJURY

If this system is to be used to collect seawater for feeding experiments with fish larvae, it is important that the prey organisms not be injured. A diaphragm pump was selected for this system in the belief that it would be less harmful to plankton than a centrifugal pump. To test for injury to microzooplankton during collection, seawater containing 0.8 organisms/ml (the same organisms that were collected for the avoidance experiments) was pumped through the system and collected in two 2-liter separatory funnels. Identical but unpumped seawater was also collected in two 2-liter separatory funnels. The 4 funnels were left undisturbed for 4 hours in a temperature-controlled room at  $17 \pm 1^\circ\text{C}$ . Then 25 ml of the seawater were drawn from the bottom and the number of organisms counted. After 24 hours, another 25 ml were collected and counted from the same funnels. There appeared to be no difference in the mortalities of organisms that were pumped through the system compared to those that did not pass through the system (Table 1). The high number of mortalities during the first 4 hours was probably due to injuries resulting from the excessive handling required to capture the zooplankton and separate out the 64-to-560- $\mu\text{m}$  size range.

### SMEARING

If the distribution of plankton is highly contagious in a region, then the sample probe might quickly pass from high-particle-density seawater to lower density. Depending on the flow characteristics through the hose and pump, the sampled water can smear during the collecting process so that it is difficult to collect seawater with representative plankton concentrations.

To test for smearing, normal pumping was established with the sample probe immersed in a tank of filtered seawater. A 1-liter "square wave" of high-particle-density seawater was introduced into the

TABLE 1  
 Comparison of Microplankton Mortality in Water Passed and Not Passed through a Diaphragm Pump

	<i>Pump</i>		<i>No pump</i>	
	Number of organisms/25 ml		Number of organisms/25 ml	
	Funnel #1	Funnel #2	Funnel #1	Funnel #2
4 hours	344	295	300	252
24 hours	27	41	35	43

pumping system with an underwater connection between the sample probe and a 1.5-cm I.D. tube connected to a graduated cylinder containing seawater with 135 rotifers/ml (*Brachionus plicatilis*). No air bubbles were introduced into the pumping system using this technique. (Air bubbles would disrupt the flow characteristics in the pump and hose.) Normal pumping of the filtered seawater was resumed after the 1 liter of seawater containing the rotifers was introduced. Fifteen 1-liter samples were collected in sequence from the pump effluent starting at 40 seconds after the rotifers were sampled, and the concentration of rotifers in each 1-liter sample was determined. There was minimal smearing: 94 percent of the rotifers introduced in 1 liter were recovered in 3 liters of discharge water.

### FIELD TRIALS

The device for sensing and collecting microplankton was tested in several sea trials off the southern California coast, in the New York Bight, and in the Austnesfjorden in the Lofoten area of Norway. The system was tested by comparing the particle concentration in discrete samples of seawater collected from the pump to the corresponding response of the detector. A good correlation was found between the response of the detecting system and the actual concentration of particles in the sampled water as determined by direct microscopic counts.

Figure 4 depicts the chart recordings of the vertical distribution of particles at one station in Austnesfjorden, Norway, on two separate days. Discrete samples were collected from the pump at various depths, and the concentrations of nauplii were determined by microscopic counts. At 2230 hours on May 15, 1977, we found a concentration of 0.6 nauplii/ml near the surface. The mean carapace length of the nauplii was  $250 \mu\text{m}$  S.D.  $\pm 48 \mu\text{m}$  ( $n = 50$ ). To our knowledge, this is the highest concentration of micronauplii ever collected at sea. It is interesting to note the contagious nature of the particle distribution. For instance, within 3 meters of the surface, the nauplii concentration had dropped by a factor of ten. Also, on May 10, 1977, the concentration of nauplii at the same station was low.

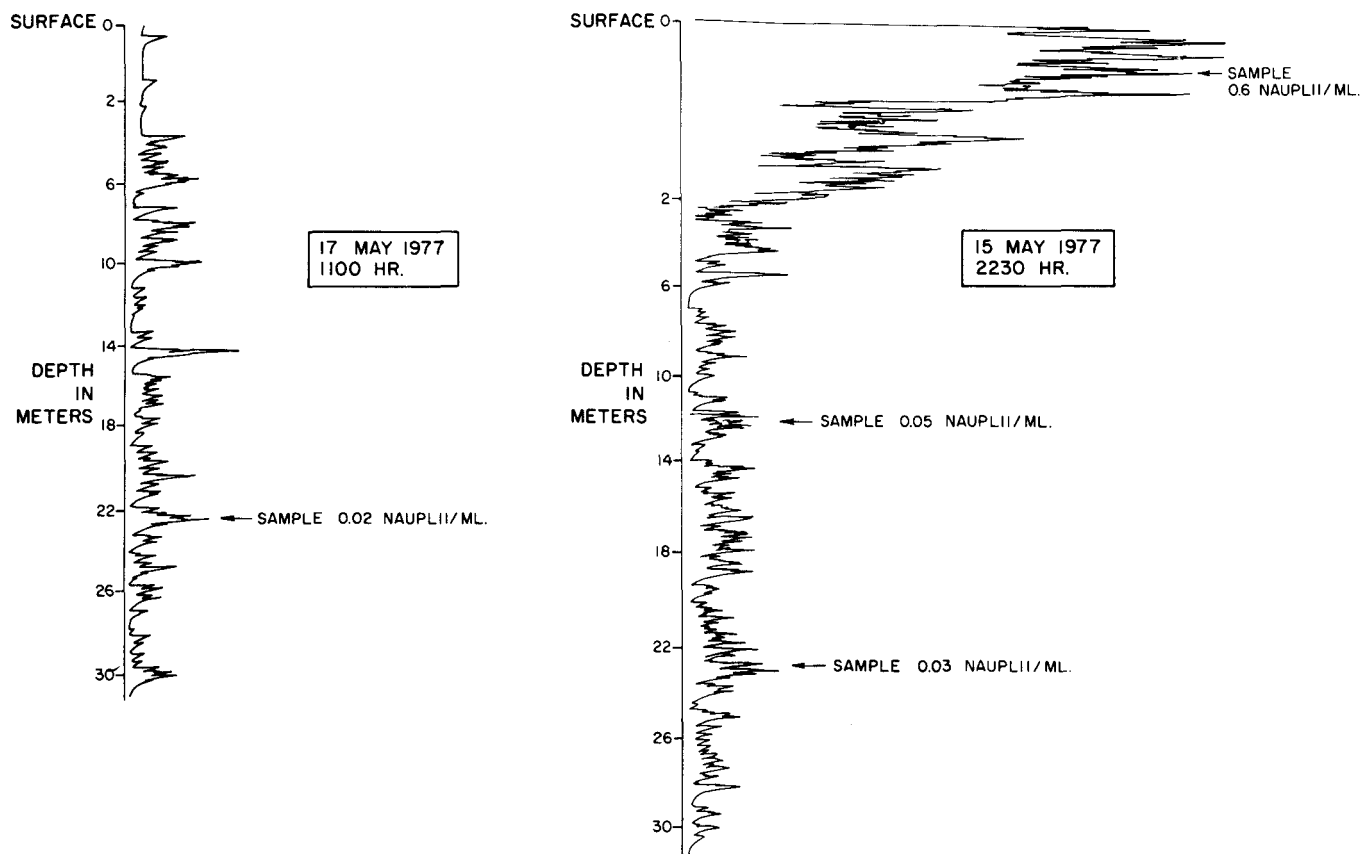

Figure 4. Chart records of vertical distribution of copepod nauplii collected in Austnesfjorden, Norway, by the *in situ* device for sensing and collecting microplankton.

In Austnesfjorden, we found the device to be very effective in identifying and collecting discrete samples of seawater from regions of high plankton density. Seawater collected in this manner was used for bioassay experiments with cod larvae to determine feeding thresholds, rates, and food preferences (Ellertsen et al. 1981).

The effectiveness of this technique depends on local conditions. For instance, during two cruises in the New York Bight, rough weather hampered attempts to identify plankton patches. It is hard to assess how much this was caused by the dispersal of patches due to mixing on the upper layers, and how much was due to the ship's movement, which made it impossible to sample discrete points in the water column.

The effectiveness of the device can also be reduced by interfering particles in the water. During one cruise off the coast of Long Island, New York, high concentrations of a large phytoplankton (*Ceratium tripos*) masked the presence of microneauplii.

## SUMMARY

The device for sensing and collecting microplankton was found to be effective during 45 days of sea trials. Effectiveness depends on local conditions

such as sea state, weather, and the presence of interfering particles like large phytoplankton or detritus that can mask the presence of microneauplii.

This device has been used successfully to collect discrete samples of seawater from regions of high nauplii density for use in larval fish bioassay experiments. To our knowledge, the highest concentration of nauplii (0.6/ml) ever found at sea was collected with this device.

Laboratory tests indicate that zooplankton nauplii less than approximately 560  $\mu\text{m}$  could not avoid the influent currents of this device. Also, there was no evidence of injury to nauplii during pumping, and smearing of the sample during collection was minimal.

An old Coulter Counter Model A was modified for this application because one happened to be available. However, an inexpensive pulse height analyser could also be used for this purpose.

## LITERATURE CITED

- Blaxter, J.H.S. 1966. The effect of light intensity on the feeding ecology of herring. *Symp. Br. Ecol. Soc.* 6:393-409.
- Boyd, C.M. 1973. Small scale spatial patterns of marine zooplankton examined by an electronic *in situ* zooplankton detecting device. *Netherlands Journal of Sea Research* 7:103-111.

- Boyd, C.M., and G.W. Johnson. 1969. Studying zooplankton populations with an electronic zooplankton counting device and the LINC-8 computer. Trans. Applications of Sea Going Computers Symposium; Marine Technology Society: 83-90.
- Ellertsen, B., P. Solemdal, S. Sundby, S. Tilseth, T. Westgård, and V. Øiestad. 1981. Feeding and vertical distribution of cod larvae in relation to availability of prey organisms. Rapp. P.-v. Réun. Cons. Int. Explor. Mer. 178: 317-319.
- Hunter, J.R. 1972. Swimming and feeding behavior of larval anchovy *Engraulis mordax* Fish. Bull., U.S. 70:821-838.
- Lasker, R. 1975. Field criteria for survival of anchovy larvae: the relation between inshore chlorophyll maximum layers and successful first feeding. Fish. Bull., U.S. 73:453-462.
- Lasker, R., H.M. Feder, G.H. Theilacker and R.C. May. 1970. Feeding, growth, and survival of *Engraulis mordax* larvae reared in the laboratory. Mar. Biol. (Berl.) 5:345-353.
- Maddux, W.S., and J.W. Kanwisher. 1965. An *in situ* particle counter. Limnol. Oceanogr. 10:R162-R168.
- May, R.C. 1974. Larval mortality in marine fishes and the critical period concept. In J.H.S. Blaxter (ed.), The early life history of fish, p. 3-19. Springer-Verlag, Berlin.
- Mullin, M.M., and E.R. Brooks. 1972. The vertical distribution of juvenile *Calanus* (Copepoda) and phytoplankton within the upper 50 m of water off La Jolla, California. In A.Y. Takenouti (ed.), Biological oceanography of the northern North Pacific Ocean, p. 347-354. Idemitsu.
- Owen, R.W. 1981. Microscale plankton patchiness in the larval anchovy environment. Rapp. P.-v. Réun. Cons. Int. Explor. Mer 178: 364-368.
- Rosenthal, H., and G. Hempel. 1970. Experimental studies in feeding and food requirements of herring larvae (*Clupea harengus* L.) In J.H. Steele (ed.), Marine food chains, p. 344-364. Berkeley: Univ. Calif. Press.
- Scura, E.D., and C.W. Jerde. 1977. Various species of phytoplankton as food for larval northern anchovy, *Engraulis mordax*, and relative nutritional value of the dinoflagellates *Gymnodinium splendens* and *Gonyaulax polyedra*. Fish Bull., U.S., 75:577-583.