

THE VERTICAL DISTRIBUTION AND FEEDING HABITS OF TWO COMMON MIDWATER FISHES (*LEUROGLOSSUS STILBIUS* AND *STENOBRACHIUS LEUCOPSARUS*) OFF SANTA BARBARA

GREGOR M. CAILLIET
Moss Landing Marine Laboratories
P.O. Box 450
Moss Landing, California 95039

ALFRED W. EBELING
Department of Biological Sciences
and Marine Science Institute
University of California
Santa Barbara, California 93106

ABSTRACT

Leuroglossus stilbius (Bathylagidae) was abundant in the nearshore Santa Barbara Basin (SBB), but less so in the more offshore Santa Cruz Basin (SCB). *Stenobranchius leucopsarus* (Myctophidae) was abundant in both basins. *L. stilbius* is adapted morphologically to feed by suction and to eat smaller, less active organisms. *S. leucopsarus* is better adapted to feed by grasping, and to eat larger, faster, and more elusive prey. In the SBB, *L. stilbius* fed, mostly at night in surface waters, on larvaceans and salps all year, reflecting the seasonally consistent abundance of these prey items. In the SCB, it fed less intensely, mostly at night in surface waters, and its diet varied with the seasonal abundance of its gelatinous prey. *S. leucopsarus* fed mainly on crustaceans, and it did not exhibit a distinct feeding chronology. It ate similar prey all year in both basins, but euphausiids dominated the diet when they were most abundant. Thus *L. stilbius* is well adapted to inshore, eutrophic midwater habitats, where it can easily eat abundant larvaceans and salps, and may act as a trophic link between the shallow gelatinous zooplankton and the deep sea through its diffuse vertical migrations. Offshore, its primary food is less dense, only seasonally available, and restricted to surface waters. *S. leucopsarus* is better adapted to eat the more varied food resources offshore. Its cohesive pattern of vertical migrations takes it into the food-rich surface waters at night, where it consumes crustacean prey and trophically transports their calories to the deep sea.

RESUMEN

La abundancia de *Leuroglossus stilbius* (Bathylagidae) fue más alta en la cuenca de Santa Barbara (SBB) que en la cuenca de Santa Cruz (SCB), ubicada a mayor distancia desde la costa. La abundancia de *Stenobranchius leucopsarus* (Myctophidae) fue similar en ambas cuencas. La especie *L. stilbius* presenta

adaptaciones morfológicas que le permiten alimentarse por succión y predear sobre organismos pequeños y poco activos. A diferencia, la especie *S. leucopsarus* está mejor adaptada a una alimentación activa, predando sobre presas más grandes y más escapadizas. *L. stilbius* se alimentó principalmente de noche en aguas superficiales de la SBB. Durante todo el año el alimento consistió de apendicularias y salpas, reflejando la persistente disponibilidad de estos organismos a lo largo del ciclo anual. El régimen alimenticio fue similar en la SCB, si bien la dieta varió de acuerdo con la variación estacional en la abundancia de las presas. No se observaron diferencias cronológicas marcadas en los hábitos alimenticios de *S. leucopsarus*. La dieta estuvo compuesta principalmente por crustáceos, en especial de euphausiidos cuando éstos eran más abundantes. El alimento fue similar en ambas cuencas. Por consiguiente, *L. stilbius* es una especie adaptada al ambiente costero eutrófico donde puede alimentarse de apendicularias y salpas en abundancia, y que debido a sus migraciones verticales difusivas es probable que represente el eslabón trófico entre el zooplankton gelatinosos de aguas poco profundas y las aguas oceánicas profundas. Lejos de la costa, su alimento principal está menos densamente distribuido, y solamente disponible estacionalmente y restringido a las aguas superficiales. La especie *L. leucopsarus* está mejor adaptada a un régimen alimenticio oceánico más variado. Su patrón de migración vertical cohesivo le permite predear en aguas superficiales ricas en alimento (donde consume crustáceos) y transportar las calorías hacia las aguas profundas.

INTRODUCTION

According to Lavenberg and Ebeling (1967) "the diversity of the mesopelagic and bathypelagic faunas increases with vertical expansion of their habitats offshore." This trend is evident when one compares the fish faunas of two deep-sea basins off Santa Barbara, California (Ebeling et al. 1970a; Brown 1974). The Santa Barbara Basin (SBB), located inshore of the Channel Islands, is relatively shallow (600 m,

with a 425-m sill), generally isolated from other basins, and enriched by coastal runoff; it has a relatively simple but abundant epipelagic and upper mesopelagic fish fauna. In contrast, the offshore Santa Cruz Basin (SCB) is much deeper (>2000 m) and is outside the immediate coastal influence, in closer contact with the deeper oceanic environment; it contains a more diverse but less abundant fish fauna. Here, allochthonous species increase in relative abundance with large-scale seasonal changes in water-mass types, and bathypelagic species occur below 500 m.

Off California, evidence suggests that phytoplankton production and standing crop are highest inshore (Malone 1971), and the zooplankton diversity increases as zooplankton density decreases offshore (Longhurst 1967). The inshore SBB is regarded as highly productive (Emery 1960; Soutar and Isaacs 1969; Sholkovitz and Gieskes 1971). Ebeling et al. (1970a) reported that catch volumes of fishes were higher there, whereas volumes of invertebrate micronekton did not differ significantly between basins. The variability in the offshore catch was greatly influenced by seasonal invasions of bulky organisms like salps. If salps are eliminated from the analysis, invertebrate standing crop was also greatest in the SBB.

The California smoothtongue, *Leuroglossus stilbius*, (Bathylagidae) and northern lampfish, *Stenobrachius leucopsarus*, (Myctophidae) are the dominant fishes in the midwater community of animals that is especially abundant off southern California (Ahlgren 1969; Ebeling et al. 1970a, 1970b; Brown 1974). *L. stilbius* was ranked first, and made up 58% of all fishes sampled. Its catch rate averaged 6.1 adults per kilometer flow through an 1.8-m Isaacs-Kidd midwater trawl (IKMT) in the SBB. It ranked only third, 16%, and 0.4 km^{-1} in the SCB. Likewise, *S. leucopsarus* ranked second, and had abundances and catch rates of 33% and 5.4 km^{-1} inshore, and ranked fifth, and had values of 11% and 0.9 km^{-1} offshore. Farther offshore, the numbers of both species dwindle, but *S. leucopsarus* is a bit more abundant than *L. stilbius* (Percy 1976; Willis and Percy 1980). Although the distributional centers of both fishes occur off California, *L. stilbius* ranges from Alaska to the Gulf of California, while *S. leucopsarus* occurs all the way from the Bering Sea to the tip of Baja California (Miller and Lea 1972; Hart 1973; Eschmeyer et al. 1983).

Ebeling et al. (1970b) theorized that "among mesopelagic fishes *L. stilbius* and to a lesser extent *S. leucopsarus* may best exploit the rich inshore basins of the borderland." What, then, differentially regu-

lates the sizes of the inshore and offshore populations of these species? Of the four key factors listed by MacArthur and Connell (1966) that regulate population sizes (reproduction, migration, mortality, and food resources), we decided to evaluate the fourth. We investigated the morphological adaptations, feeding habits, and vertical migration patterns of the two fishes to determine what kinds of prey they took, how they migrated vertically relative to prey availability, how their use of available food might influence their relative success in the inshore and offshore areas, and how they might affect the vertical flux of organic material in the water column.

MATERIALS AND METHODS

Fishes were collected from 1964 through 1968 during 33 regular cruises of the R/V *Swan* off Santa Barbara, California (cf. Ebeling et al. 1970a; Brown 1974). All collections were made with a 1.8-m IKMT, which had a lining of 1-cm stretch mesh netting, followed by a standard zooplankton net and a cod-end sampler, divided into four chambers by electronically closed gates (Aron et al. 1964; Bourbeau et al. 1966). Samples of animals from particular depth intervals were thus separated by the sequentially closed gates. The trawl's spreader bar contained electronic sensors to monitor depth and water temperature. A flowmeter measured sampling effort in meters trawled. The signals from all sensors and flowmeter were transmitted simultaneously through the towing cable to shipboard recorders.

Collections were regularly made in the generally recognized major depth zones: (1) epipelagic, in the surface wind-mixed layer about 0–200 m; (2) upper mesopelagic, within the permanent thermocline, about 200–400 m; and (3) lower mesopelagic, in the dysphotic depths, below 400 m. Maximum trawl depth varied between 500 and 1000 m, depending on the area sampled. Only shallow and mid-depth samples could be taken in SBB, which lacks a bathypelagic zone. The more typically oceanic and deeper SCB has a bathypelagic zone that extends well below the depth of the lower mesopelagic. Samples were taken throughout the year at night and during the day. A total of 205 stations yielded 631 collections, 363 of which were from discrete-depth hauls whose vertical excursions were at least 50% within the 200-m depth intervals. An additional 40 samples through broader depth intervals were used to estimate seasonal abundance of potential prey, such as salps and euphausiids.

All fishes were preserved on board in 10% buffered Formalin and seawater, and subsequently

changed to 45% isopropyl alcohol ashore. Specimens of *L. stilbius* and *S. leucopsarus* were routinely identified, counted, and measured, along with other fishes and invertebrates of each trawl catch within a few months after collection (Ebeling et al. 1970a). Small fishes (less than 50 mm standard length, SL) were arbitrarily distinguished from larger fishes. Very small individuals of both species were caught but were not adequately sampled because many probably escaped through the mesh. Abundances of both species were standardized among collections by sampling effort, measured in meters but defined in units of kilometers towed.

The depth distributions of the two species, pooled for all months, were analyzed separately for four time intervals—late night (0001–0600 hrs); morning (0601–1200 hrs); afternoon (1201–1800 hrs); and early night (1801–2400 hrs)—and for five depth intervals—0–200 m, 201–400 m, and >400 m in the SBB and SCB, plus the deeper zones 600–800 m and >800 m in the SCB. Histograms of bathymetric distribution of abundances were constructed for these four categories of day and night captures in the “at-depth” hauls. The same procedure was followed for analyzing the depth distributions of two species of prey caught in the trawls. Their seasonal abundances, pooled for all years by month and season, were also analyzed for both basins.

Measurements and counts of the following alimentary structures were taken to compare the feeding abilities of the two species: jaw length; width of gape; number and size of teeth; number, size, and structure of gill rakers; and the length and general structure of the stomach, intestine, and pyloric caeca. In all, 647 *L. stilbius* and 677 *S. leucopsarus* were measured, weighed, and dissected. The lengths and weights were used to calculate a “condition factor” (Cailliet et al. 1986). The gut was exposed by opening the coelom. The entire alimentary tract was removed by cutting at the esophagus and pulling it out. The stomach was then split longitudinally from the pyloric sphincter to the esophagus.

For *L. stilbius*, which has two stomachs, the cut was made from the posterior end of the pyloric stomach, through the cardiac stomach to the esophagus. Only the contents of the pyloric stomach were analyzed for this study, since the cardiac stomach contents were more likely to reflect net feeding (Anderson 1967; Lancraft and Robison 1980).

For *S. leucopsarus*, however, there was only one stomach to analyze. Collard (1970) felt that net feeding was minimal in his study of *S. leucopsarus* feeding habits. Likewise, Hopkins and Baird (1975) reported that feeding in midwater trawls did not

significantly alter feeding habit results. However, Lancraft and Robison (1980) found simulated prey items in 23.3% of the guts of *S. leucopsarus*. Therefore, we used stomach contents with scales to estimate possible bias in this species. We compared rank orders of diets of fish with scales in their stomachs with those without scales for both basins, using Kendall's nonparametric rank correlation (Sokal and Rohlf 1969).

With contents intact, the fullness of the gut was subjectively scored as: 0 = empty; 1 = 25% full; 2 = 50% full; 3 = 75% full; and 4 = 100% full. The contents were then removed, identified to the lowest possible taxon, measured with an ocular micrometer, and counted. The percent volume contribution of each prey item was subjectively estimated. Any intestinal parasites were identified, counted, and measured.

The index of relative importance (IRI) of each prey item was estimated for food-containing fish by each time and depth category as a linear combination of its numerical importance (N), volumetric importance (V), and frequency of occurrence (FO) (Pinkas et al. 1971). The numerical importance of a particular item was the percentage ratio of its abundance to the total abundance of all items in the contents. Its volumetric importance was its average percent volume. Its percent frequency of occurrence was the percentage of fish containing at least one individual. The combination resulted in: $IRI = (N + V) \times F$, which is represented by the area of a rectangle resolved by plotting the three importance measures on a three-way graph (Cailliet et al. 1986). The value of IRI ranges from zero, when all three values are zero, to 20,000, when all three indices are 100% (a monodiet). The IRI ranks the relative importance of dietary items, and the three-way graph indicates which measures of importance were most meaningful.

Stomach contents of the two fishes were compared between basins and among oceanographic periods within basins. These periods were defined as: (I) a surface mixing period from January through April, when cold weather and stormy turbulence causes surface cooling; (II) an upwelling period of surface enrichment from May through July, when the California Current is strongest and intensifies the counterclockwise current gyre over the southern California continental borderland; and (III) a period of thermal stratification, from August through December (Brown 1974; Jones 1971; Sholkovitz and Gieskes 1971).

Possible correlations of rank hierarchies of stomach contents were tested between species, basins,

and among oceanographic periods via Kendall's tau rank correlation (Sokal and Rohlf 1969). We used the numerical importance of prey items eaten (lowest possible taxon, but not necessarily species) to calculate several diversity indices. Because all indices produced similar results, we will present only the *NM* (number of moves) indices (Fager 1972).

The differences in abundance of two of the principal food items among oceanographic periods were also estimated. We calculated the mean numbers of *Salpa fusiformis* and *Euphausia pacifica* per km trawled and compared them with the seasonal occurrence of these prey in the stomachs of *L. stilbius* and *S. leucopsarus*. This analysis could not be done for smaller or delicate items, such as larvaceans, copepods, and ostracods, because of destruction, avoidance, escape, or extrusion.

To determine recency and amount of feeding for different time and depth categories, we combined estimates of fullness and state of digestion. A 4×4 matrix of fullness by digestion for each time and depth category resolved major feeding states of (A) not recently eaten or full, including empty stomachs (i.e., fullness states 0, 1, and 2 vs. digestion states 1 and 2); (B) recent but not full (fullness states 0, 1, and 2 vs. digestion states 3 and 4); (C) recent and full (fullness states 3 and 4 vs. digestion states 3 and 4); and (D) full but not recent (fullness states 3 and 4 vs. digestion states 1 and 2). Fullness-recency histograms measured frequencies of the major feeding states for both species between basins among the four time intervals (late night, morning, afternoon, and early night) and the three depth intervals (0–200, 201–400, and >400 m).

RESULTS

Alimentary Morphology

L. stilbius has a smaller mouth than *S. leucopsarus* (figure 1). The mean ratio of upper jaw length to standard length was 6.2 ($n = 170$) for adult *L. stilbius*, but 17.3 ($n = 41$) for adult *S. leucopsarus*. The mean ratio of gape width to standard length was 5.9 for *L. Stilbius* and 8.9 for *S. leucopsarus* (figure 2). Assuming that these fishes can open their mouths to a 45° angle, the effective mouth area of *S. leucopsarus* is about four times that of *L. stilbius*.

L. stilbius has very few teeth in its mouth (figure 1). It has none on its premaxilla or tongue and few on its palatine, vomer, and dentary bones (Chapman 1943; Borodulina 1968). *S. leucopsarus*, on the other hand, has well-developed premaxillary, palatine, pterygoid, and dentary teeth (Bolin 1939; Jollie

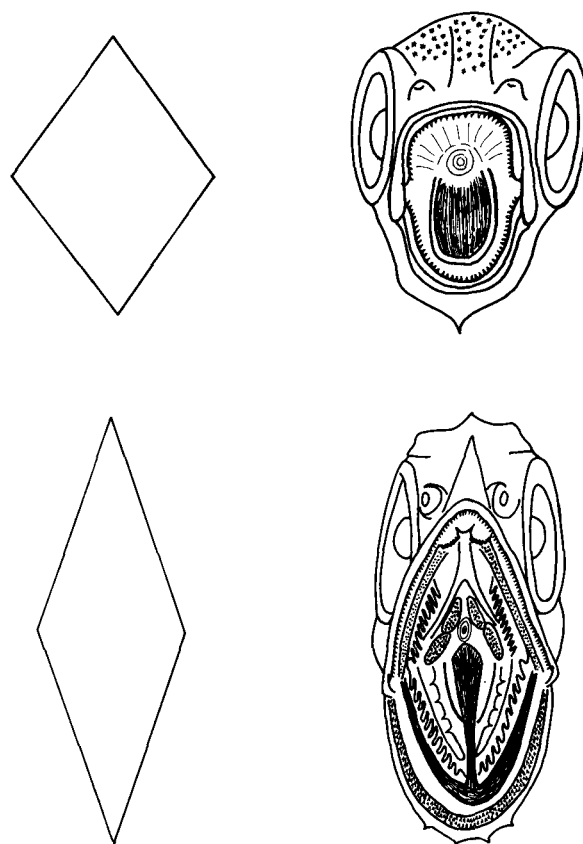

Figure 1. Mouth shape and front view of the head of *L. stilbius* (above) and *S. leucopsarus* (below).

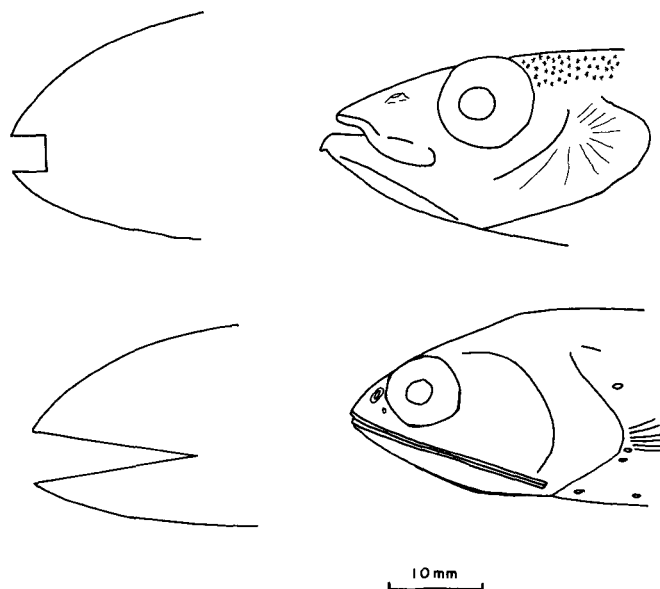

Figure 2. Side views of heads and mouths of a fish with a small mouth and *L. stilbius* (above), and a fish with a large mouth and *S. leucopsarus* (below).

1954; Berry 1964). Unlike *L. stilbius*, it has well-developed pharyngeal teeth to help move food into the gut (Jollie 1954). With more teeth, *S. leucopsarus* may better grasp and hold larger and more active prey.

L. stilbius has significantly more gill rakers on its first arch (26–29, cf. Borodulina 1968) than *S. leucopsarus* (17–19, cf. Jollie 1954; figure 3). The front edges of its rakers are smooth, not toothed like those of *S. leucopsarus*. The average distance between rakers of an individual measuring 60 mm SL was only 0.3 mm, compared with 0.7 mm for *S. leucopsarus*. Also, the gill rakers of *L. stilbius* are more broadly flattened (Borodulina 1968) and tend to close together when water is forced over them.

The stomachs of the two fishes also differ markedly. *L. stilbius* has a double stomach, with a cardiac portion preceding the pyloric portion (figures 4 and 5). The cardiac stomach is covered with a black pigment, an adaptation that may prevent light from bioluminescent prey from showing through (McAllister 1961). This stomach has a very thick wall, and its inner mucosa is made up of many posteriorly oriented rugae (figure 5). The pyloric stomach is thin-walled and flexible. In contrast, *S. leucopsarus* has only one thick-walled stomach, also covered with a black pigment (McAllister 1961). The internal mucosa is made up of typhlosole ridges that run longitudinally (figure 5).

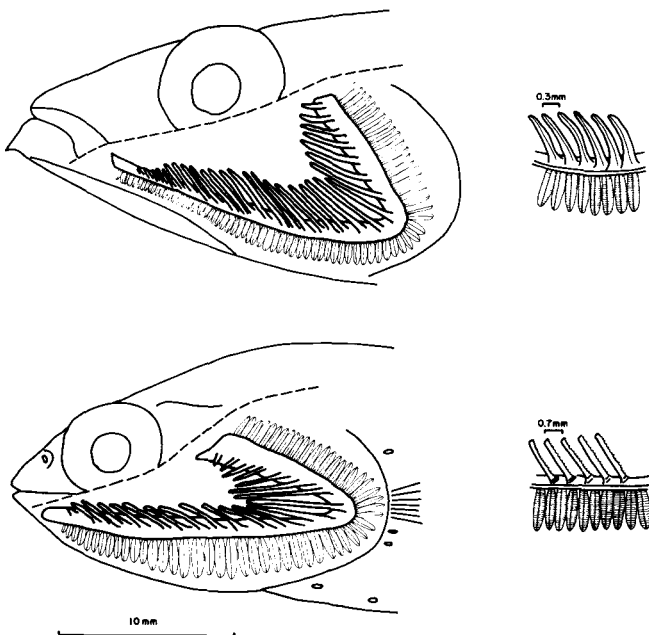

Figure 3. Lateral cutaway view of the gill arches and rakers of *L. stilbius* (above) and *S. leucopsarus* (below).

The number of pyloric caeca and relative intestinal lengths also differ considerably (figure 5). *L. stilbius* has more caeca (8–11, cf. Borodulina 1968) than *S. leucopsarus* (4–6, cf. Jollie 1954). Its intestine length averaged 50.5% of its SL ($n = 22$), compared with only 28.0% for *S. leucopsarus* ($n = 35$).

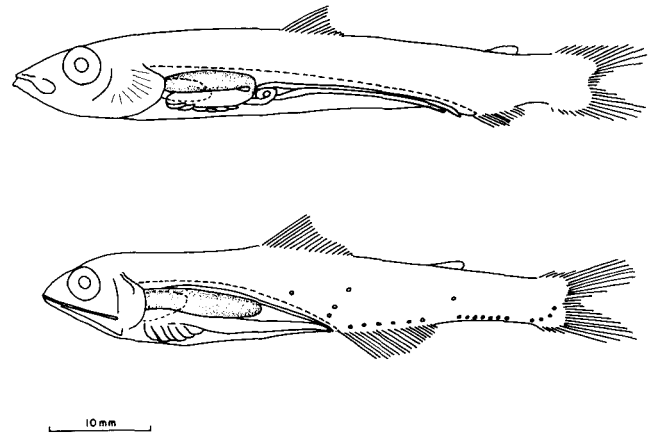

Figure 4. Lateral cutaway view of the body and alimentary tract of *L. stilbius* (above) and *S. leucopsarus* (below).

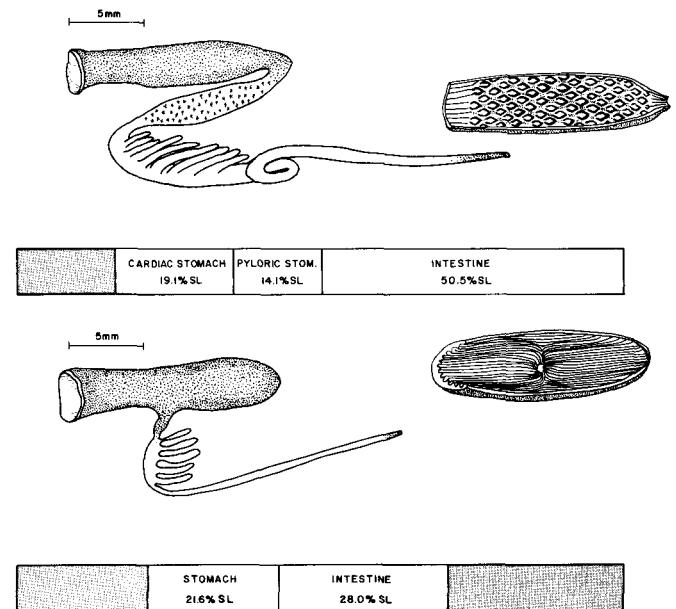

Figure 5. Internal alimentary structures of *L. stilbius* (above) and *S. leucopsarus* (below). The upper left drawing for each species is the alimentary canal, showing the stomach(s) (stippled and starred), intestinal tract, and pyloric caeca. The upper right drawing for each species shows a longitudinal cutaway of the stomach, either lined with posteriorly oriented rugae (*L. stilbius*) or typhlosole ridges (*S. leucopsarus*). Bar diagrams indicate the average lengths of stomach(s) and intestine relative to standard length for both species.

Feeding Habits

In the SBB, *L. stilbius* ate primarily larvaceans (genus *Oikopleura*) and salps (probably *Thalia democratica* and *S. fusiformis*; Berner 1957, 1967; Hubbard and Pearcy 1971; M. Silver, pers. comm.), followed, in order, by ostracods, small copepods (1–2 mm), zoea, and *E. pacifica* (figure 6). Salps, which were larger than the more numerous larvaceans, made up the greater dietary bulk. Less-important items included copepods (2–3 mm and <1 mm), chaetognaths, fish eggs, siphonophores, nauplii, and larger copepods (>3 mm).

The rank order of prey in *L. stilbius* stomachs was significantly correlated between basins (Kendall's tau = 0.51, $P < 0.01$). Even so, the SCB fish had a slightly more varied diet, which differed in minor ways. They ate relatively fewer ostracods, more nauplii, and more large copepods, with such things as amphipods (*Hyperia galba*) and shrimp (mysids and sergestids) in lesser amounts. Also, the larva-

ceans were both numerically and volumetrically important, while the salps were important only volumetrically. In both basins the prey diversity indices (Fager 1972) were low (SBB, $NM = 0.20$ and SCB, $NM = 0.11$), indicating that *L. stilbius* concentrated on only a few prey items, hence the truncated shape of the IRI diagrams (figure 6). Net feeding could not have biased these results, which were based on pyloric stomach contents only. Indeed, fish scales were never found in these stomachs.

The diet of *S. leucopsarus* was also similar between basins (tau = 0.63; $P < 0.01$) but was uncorrelated with that of *L. stilbius* (SBB: tau = 0.16, $P \sim 0.35$; SCB: tau = 0.08, $P \sim 0.64$). In the SBB, *S. leucopsarus* ate ostracods, *E. pacifica*, and a variety of "large" copepods, with no item predominating unless all size classes of copepods are pooled (figure 7). Less-important items were fish eggs, the euphausiid *Nematoscelis difficilis*, zoea, the amphipod *H. galba*, shrimp (mysids and sergestids), chaetognaths, fish larvae, siphonophores, salps, and "small" copepods (<1 mm).

The SCB *S. leucopsarus* ate relatively more euphausiids (figure 7). Like *L. stilbius*, they ate relatively fewer ostracods, and more large copepods. Amphipods were mainly *Paraphronima crassipes*. The prey diversity inshore ($NM = 0.28$) was lower than in fish offshore ($NM = 0.34$), but in both cases was higher than for *L. stilbius*, implying that *S. leucopsarus* generally ate more types of food, hence the elongated appearance of the *S. leucopsarus* IRI diagrams (figure 7).

Fish scales occurred in relatively high frequencies in *S. leucopsarus* stomachs (26.5% of SBB and 13.1%

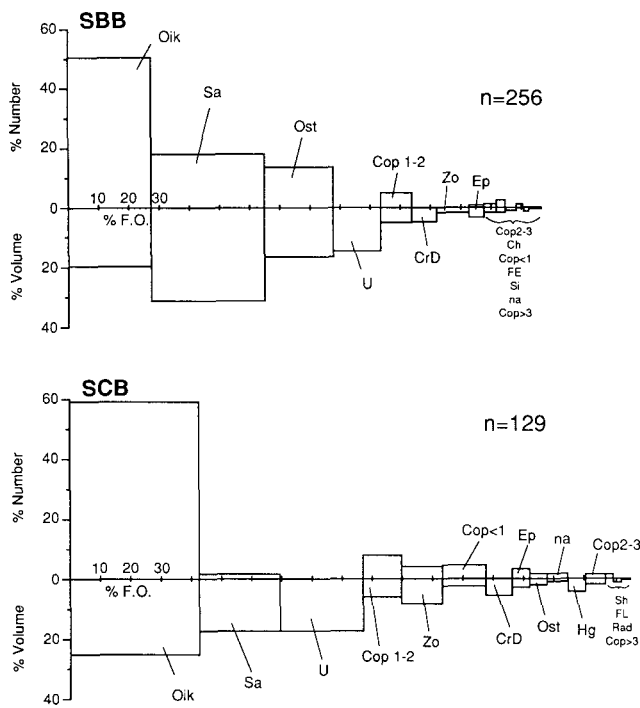

Figure 6. Percent composition of major prey items in number, volume, and frequency of occurrence (% F.O.) and ranked by the index of relative importance (IRI) from left to right for *L. stilbius* in the Santa Barbara Basin (SBB) and Santa Cruz Basin (SCB). n = the number of guts analyzed. Code of abbreviations: Ch = chaetognaths; Cop <1 = copepods smaller than 1 mm; Cop 1–2 = copepods 1–2 mm; Cop 2–3 = copepods 2–3 mm; Cop >3 = copepods larger than 3 mm; CrD = crustacean debris; Ep = *Euphausia pacifica* (euphausiid); FE = fish eggs; FL = fish larvae; FS = fish scales; Hg = *Hyperia galba* (amphipod); na = nauplii; Nd = *Nematoscelis difficilis* (euphausiid); Oik = *Oikopleura* spp. (larvacean); Ost = ostracods; Pcr = *Paraphronima crassipes* (amphipod); Rad = radiolarian; Sa = salps; Sh = shrimp (mysids and sergestids); Si = siphonophores; Zo = zoea; U = unidentifiable.

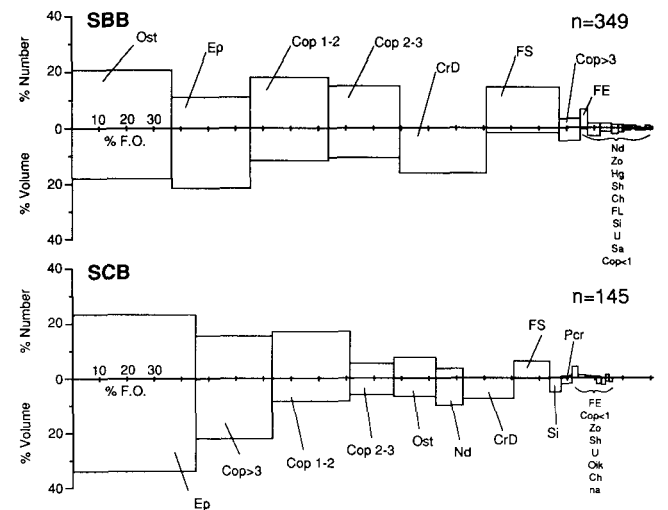

Figure 7. Percent composition of major prey items for *S. leucopsarus*. Abbreviations as for figure 6.

of SCB fish). These scales, an unlikely food, were probably ingested in the trawl net as "net feeding" (Collard 1970; Hopkins and Baird 1975; Lancraft and Robison 1980). However, "scaled" and "unscaled" diets were significantly correlated (SBB: $\tau = 0.83$, $P \ll 0.001$; SCB: $\tau = 0.92$, $P \ll 0.001$). Therefore, net feeding apparently did not systematically bias the observed dietary composition, and fish with scales in their stomachs were not eliminated from the analysis.

Seasonal Variation in Feeding Habits

In the SBB, the prey of *L. stilbius* reflected the relatively even yearly distribution of the food supply. Fish ate about the same kinds of prey all year, mostly larvaceans and salps (figure 8), and the ranks of food items were significantly correlated among seasons ($W = 0.85$, $P \ll 0.001$). Salps were equally abundant in the cold mixing (I) and upwelling (III) periods (figure 9), but were lower during the spring upwelling season (II), which may account for a slight coincident change in the fish's diet. Although larvaceans ranked first in dietary importance during periods I and II, salps ranked first during the warmer stratification season (III), when they were slightly more common in the inshore plankton. During period III, ostracods ranked second, and larvaceans third in the fish's diet. We have no way of assessing the availability of larvaceans like *Oikopleura*. Euphausiids were eaten in noticeable numbers only during period I, followed in rank by large copepods, crab zoea, and small copepods. During periods II and III, ostracods, small copepods, and large copepods completed the diet.

In the SCB, however, significant changes in the diet of *L. stilbius* seemed to reflect concomitant sea-

sonal changes in the food supply. The fish ate mostly larvaceans and salps during periods I and II, but mostly copepods during period III (figure 8). Ranks of dietary items were not significantly correlated between periods I and II ($\tau = 0.18$, $P \sim 0.4$), mainly because larvaceans did not dominate in period II and salps did not even rank in the top six during period I. Periods II and III were also not correlated ($\tau = 0.45$, $P \sim 0.02$) because copepods of all sizes were commonly eaten during period III, but larvaceans and salps were not. Of secondary rank during period I were large and small copepods, crab zoea, and chaetognaths. During period II, salps, small copepods, euphausiids, and zoea were secondary. During period III, a diversity of large and small copepods outranked zoea, larvaceans, and salps. SCB catches of *S. fusiformis* (unlike those from the SBB) decreased abruptly from period I to periods II and III (figure 9).

In the SBB, the relatively varied diet of *S. leucopsarus* did not reflect the seasonal changes in food supply. *S. leucopsarus* ate mostly small copepods and

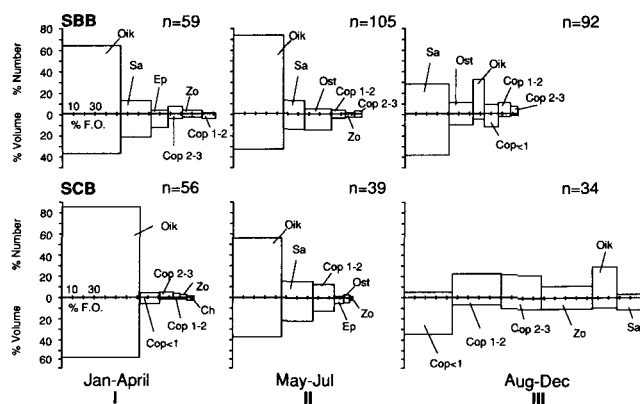

Figure 8. Percent composition of the six top-ranking prey items for *L. stilbius* for three oceanographic periods. Abbreviations as for figure 6.

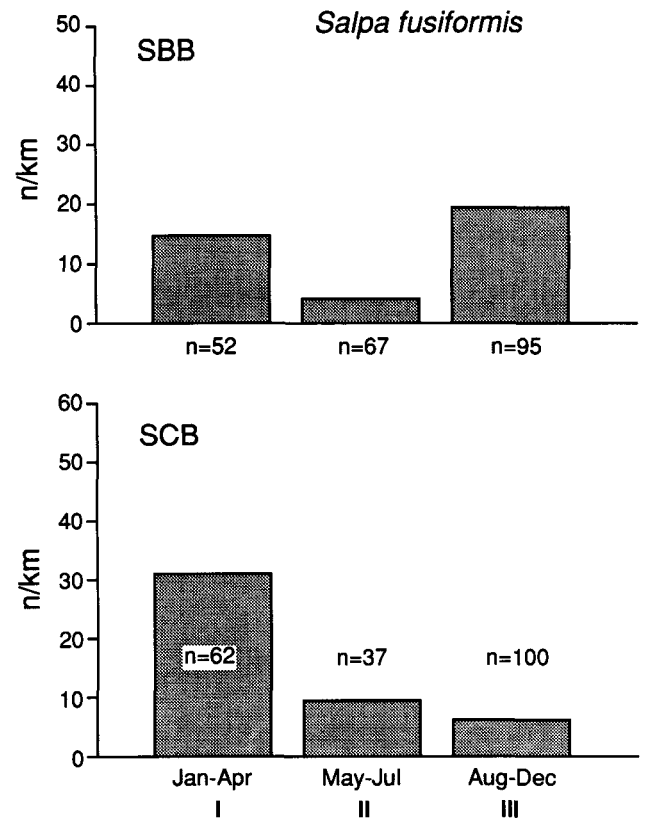

Figure 9. Changes in abundance (number per km sampled) of *Salpa fusiformis*, a major prey of *L. stilbius*, from IKMT discrete depth tows (n = sample size) in the upper 500 m of the Santa Barbara (above) and Santa Cruz (below) basins for three oceanographic periods.

ostracods during period I, but more euphausiids (*E. pacifica*) during periods II and III (figure 10). Ranks of food items differed significantly between periods I and II ($\tau = 0.37, P \sim 0.045$), but were correlated between periods II and III ($\tau = 0.45, P < 0.01$). *E. pacifica* catches were low during period I (figure 11), when the fish ate mostly copepods and ostracods. *E. pacifica* ranked first in the diet during periods II and III, but was much more abundant in catches during period II than III. The remainder of the fish's diet comprised large copepods, euphausiids, and chaetognaths during period I; large and small copepods, ostracods, and fish eggs during period II; and ostracods, small copepods, other euphausiids (*N. difficilis*), and large copepods during period III.

In the SCB, however, the dominant prey of *S. leucopsarus* were also the most abundant in midwater trawl catches. *S. leucopsarus* ate both large and small copepods during period I, when *E. pacifica* was not abundant, and *E. pacifica* during periods II and III (figure 10), when they were abundant in the plankton (figure 11). Ranks of food items differed markedly between periods I and II ($\tau = 0.20, P \sim 0.3$), and between periods II and III ($\tau = 0.49, P \sim 0.04$), even though *E. pacifica* dominated the diet in these two periods. The remainder of the diet comprised the same kinds of items eaten in the SBB.

Diel Vertical Migrations

L. stilbius migrated vertically in a diel pattern that differed somewhat between basins. In the SBB, the fish were abundant in the surface waters during the afternoon and early night, in deep waters during late night, and at mid-depth during the morning (figure 12). A significant portion of the population was

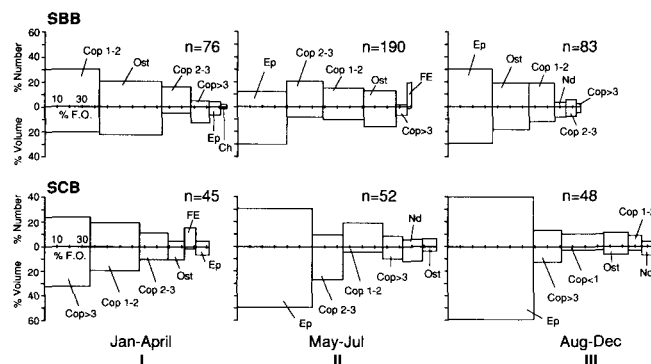

Figure 10. Percent composition of the six top-ranking prey items for *S. leucopsarus* for three oceanographic periods. Abbreviations as for figure 6.

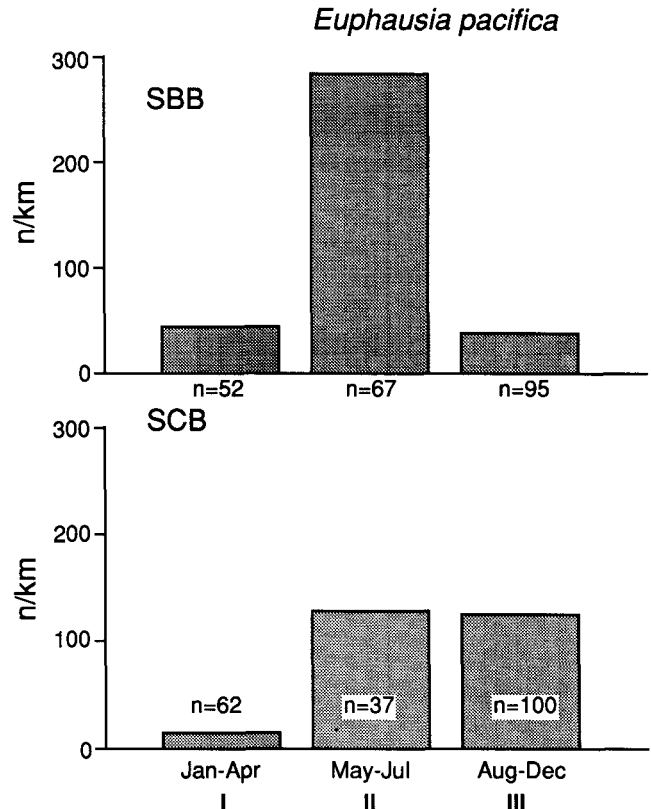

Figure 11. Changes in abundance of *Euphausia pacifica*, a major prey of *S. leucopsarus*, from IKMT discrete depth tows ($n =$ sample size) in the upper 500 m of the Santa Barbara (above) and Santa Cruz (below) basins for three periods.

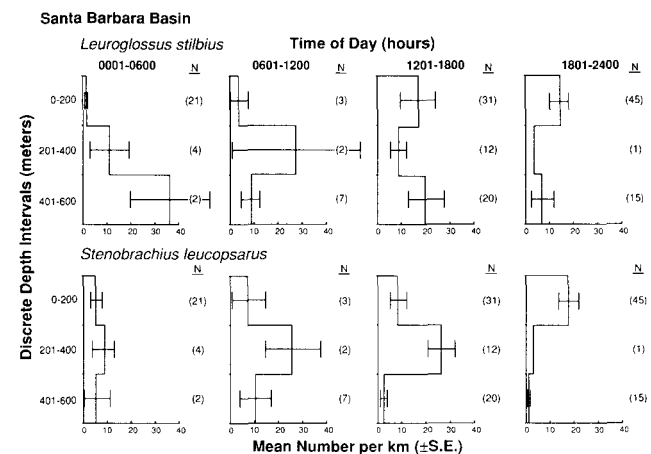

Figure 12. Diel vertical distribution patterns for *L. stilbius* and *S. leucopsarus* in the Santa Barbara Basin. Data were pooled for all months among four 6-hour time intervals and three 200-m depth intervals. The horizontal axis measures abundances, \pm standard errors, standardized by trawling effort as numbers per km flow. The numbers in parentheses represent the sample size (number of tows) for each time-depth category.

found near the bottom of this shallow basin during all periods, and the fish did not stay near the surface all night. In the deeper SCB, they had a broader vertical distribution: some of the fish were found in the surface waters in the evening, especially during the late night and early morning, and more were found in deeper water (401–600 m), especially during late night and daytime (figure 13). A significant portion of the population occurred at mid-depths (<400 m) during all periods.

The migratory pattern of *S. leucopsarus*, on the other hand, was quite predictable and similar between basins. In both the SBB and SCB, most of the population was found in the surface waters at night and at mid-depth during the day (figures 12 and 13). Consequently, the shallow SBB did not seem to compress the vertical range of *S. leucopsarus* like it did that of *L. stilbius*, nor did a significant portion of the *S. leucopsarus* population occur below 400 m in either basin.

Fullness and Recency of Feeding Relative to Vertical Migration

In the SBB, *L. stilbius* apparently fed most intensely during the night in the surface waters; it fed

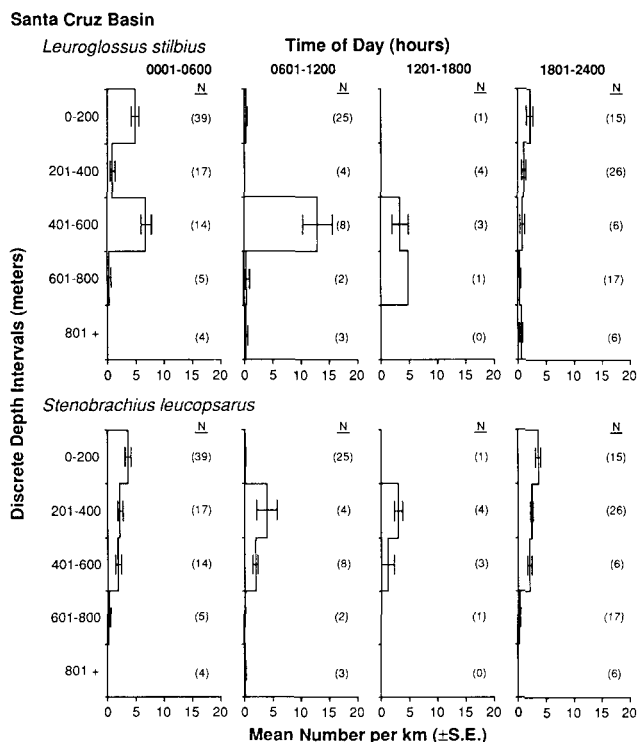

Figure 13. Diel vertical distribution patterns of the two species in the Santa Cruz Basin. Note the difference in the horizontal axis dimensions. All other details as in figure 12.

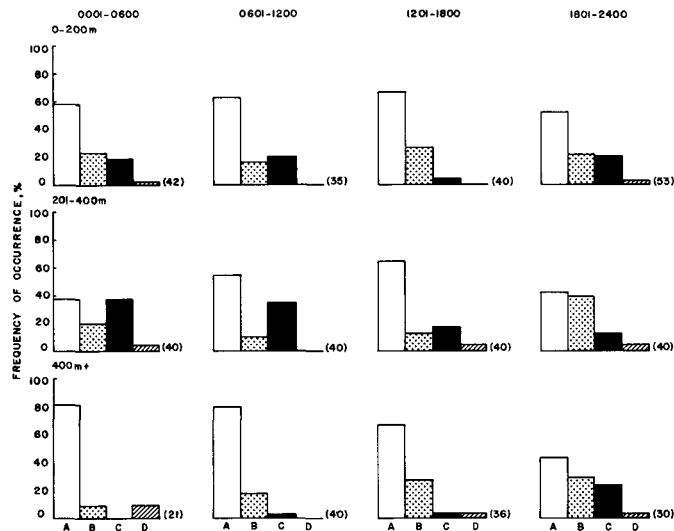

Figure 14. Fullness and recency-of-feeding histograms for *L. stilbius* in the Santa Barbara Basin pooled over all months among four 6-hour time and three depth intervals. The vertical axis measures the percent frequency of occurrence by time-depth category for fullness-recency states: A (open), not recently eaten or full; B (stippled), recent but not full; C (shaded), recent and full; and D (hatched), full but not recent. The numbers in parentheses equal the number of fish in each time-depth category.

some during both day and night at mid-depth (figure 14). Fish caught at night in the surface waters and at mid-depth had the highest percentages of “recently full” stomachs. Fish caught in the surface during the daytime, and below 400 m at all times had very high percentages of “not recent or full” stomachs, and therefore had not been actively feeding. Fish from the mid-depth during the day tended to have contents equally distributed over the fullness-digestion categories, indicating that their stomachs contained previously ingested items mixed with newly ingested ones.

In the SCB, however, *L. stilbius* generally fed less intensely, and mostly at night. Fish had relatively high percentages of “recent but not full” stomachs only during the night near the surface, and of “full and recent” stomachs only during late night and at all depths (figure 15). Few fish fed to fullness, and fish had high proportions of “not full or recent” stomachs in all time-depth categories for which there were sufficient samples.

S. fusiformis, a common prey of *L. stilbius*, was mainly limited to the upper 200 m, whenever it was collected (figure 16). In the SBB, this salp was relatively abundant in these surface waters at all times of the day. Only during the late night was it available in deeper (401–600 m) waters. In the SCB, however, these salps were caught mainly at night in the upper 200 m, and they were seldom caught during daylight hours.

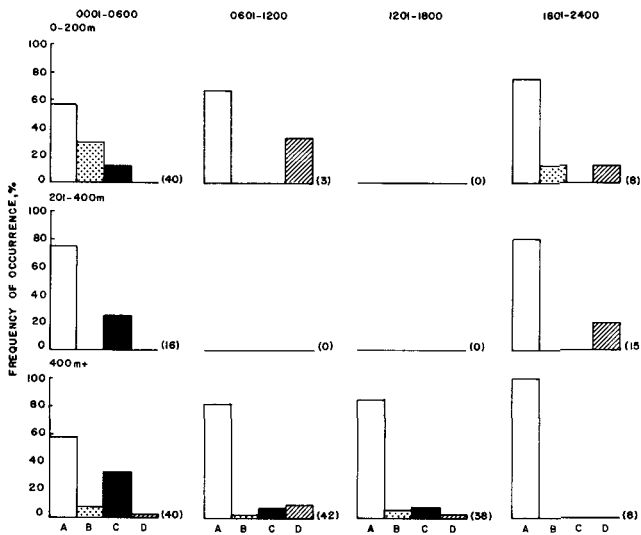

Figure 15. Fullness and recency of feeding histograms for *L. stilbius* in the Santa Cruz Basin. All details as in figure 14.

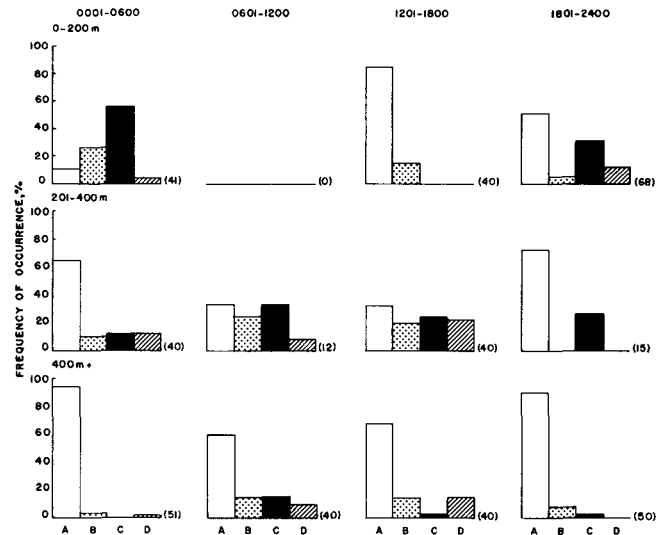

Figure 17. Fullness and recency of feeding histograms for *S. leucopsarus* in the Santa Barbara Basin. All details as in figure 14.

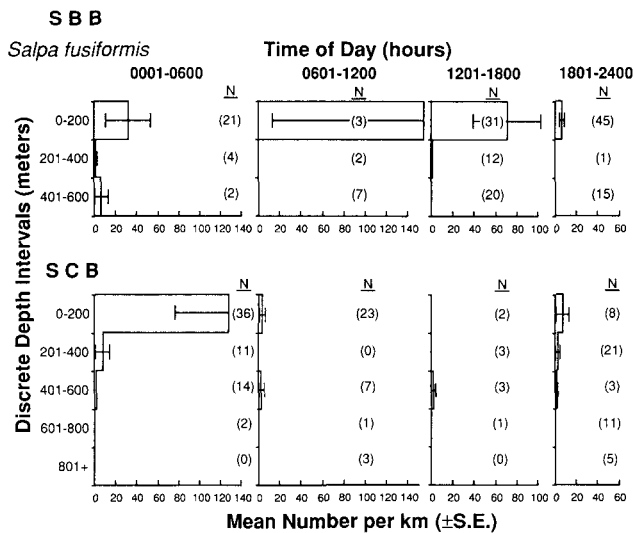

Figure 16. Diel vertical distribution of patterns of *Salpa fusiformis*, a major prey of *L. stilbius*, in the Santa Barbara (above) and Santa Cruz (below) basins. The horizontal axis measures the abundance standardized for trawling effort as numbers per km flow, \pm standard errors. Data were pooled for all months for four 6-hour time intervals and three or five 200-m depth intervals. The numbers in parentheses represent the number of IKMT tows in each time-depth category.

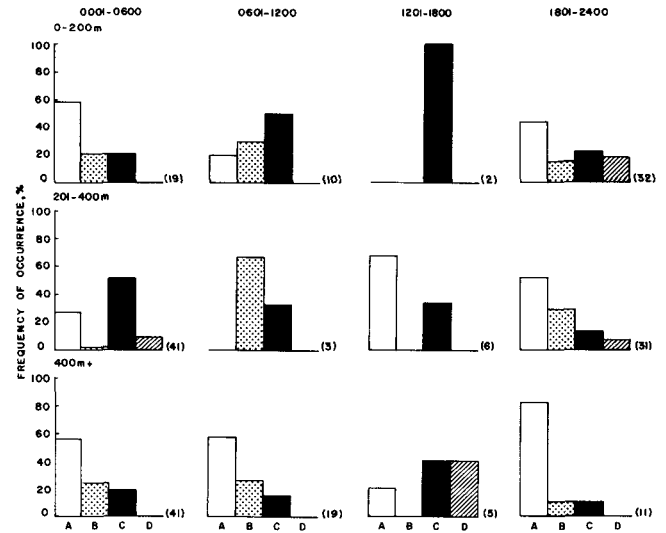

Figure 18. Fullness and recency of feeding histograms for *S. leucopsarus* in the Santa Cruz Basin. All details as in figure 14.

In both basins, *S. leucopsarus* appeared to have fed at all times and depths as the opportunity arose. It did not exhibit a distinct feeding cycle. High percentages of “recent but not full” and “full and recent” stomachs occurred in most time-depth categories (figures 17 and 18). However, the highest percentages of recent feedings were observed in fish from the upper 400 m in both basins. Fish from waters deeper than 400 m generally had high per-

centages of “not recent or full” stomachs, indicating that they had not eaten much at depth.

In both basins *E. pacifica*, a common prey of *S. leucopsarus*, exhibited a typical migration pattern of occupying the upper 200 m during the night, and dwelling mainly between 200 and 400 m during the day (figure 19). This species was abundant in both basins but did not appear in significant numbers in water deeper than 400 m. Therefore, *S. leucopsarus* must have consumed these euphausiids in the upper 400 m, no matter what time of day.

L. stilbius was more heavily parasitized inshore, whereas *S. leucopsarus* appeared equally parasitized

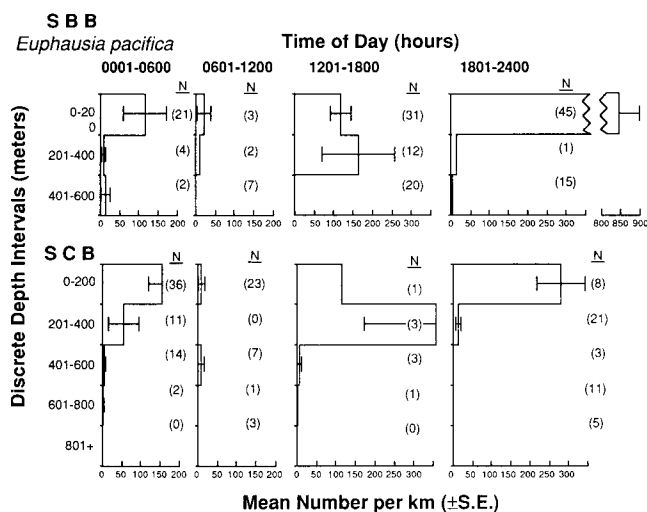

Figure 19. Diel vertical distribution patterns of *Euphausia pacifica*, a major prey of *S. leucopsarus*, in the Santa Barbara (above) and Santa Cruz (below) basins. All other details as in figure 16.

both inshore and offshore. In the SBB, 29.5% of the *L. stilbius* were parasitized by *Aponurus californicus*, but only 5.7% from the SCB were infected; 4.4% of the *S. leucopsarus* specimens from the SBB were infected by anisakine nematodes, whereas 7.8% from the SCB were infected. The coefficients of conditions (Cailliet et al. 1986) did not differ between species or basin.

DISCUSSION

Alimentary Morphology

Alexander (1967) stated that fishes with smaller mouths can better suck in their prey, whereas fishes with larger mouths can better grasp prey from the side. Therefore, *L. stilbius* would be better at sucking in abundant soft items (soft-bodied salps and larvaceans), and *S. leucopsarus* would be better at grasping a greater diversity of larger or more elusive prey (copepods and euphausiids).

The structure and behavior of soft-bodied, gelatinous prey must be considered when interpreting how *L. stilbius* captures them. Larvaceans secrete houses around themselves, which Alldredge (1976c) proposed to be a protective mechanism. Because *L. stilbius* appeared to have only the larvacean itself in its gut, either it ingested little of the house, or the house is difficult to detect in stomach contents. Underwater observations of *L. stilbius* indicate that they are relatively passive (Barham 1970). It is possible that they can slowly approach larvaceans in their

houses and locate the animal either by the beating of its tail or from bioluminescence created by organisms living on or in contact with its house. They can then suck the larvacean out, ingest the whole complex, or scare the animal away from its house and then catch it and suck it in.

Salps are patchy and seasonally common, and can exist solitarily or in strings (Berner 1967; Hubbard and Percy 1971; Silver 1975). They are probably encountered by individual fish, presumably in the surface waters and sometimes in the daytime when *L. stilbius* can see them and suck them in. Both gelatinous prey were often found in quantity in an individual gut. Thus, *L. stilbius* must feed often on patches of prey.

Yasuda (1960a,b) reasoned that a fish's gape width determines its ability to trap its prey, while its jaw length determines the size of its prey. Because the two species have similar gape widths, they should be equally adept at trapping. But *S. leucopsarus* has the longer jaw and should therefore eat larger prey, as substantiated by the studies of feeding habits.

In general, the gill rakers of most types of fishes constitute a sieve for filtering and catching food (Martin and Sandercock 1967; Yasuda 1960c; Yasuda and Hiyama 1957). Plankton feeders generally have especially well-developed gill sieves comprising many rakers and accessory processes. Obviously the rakers of *L. stilbius* make the more effective barrier for retaining smaller prey. The more widely spaced and toothed rakers of *S. leucopsarus* are probably better at retaining larger food.

Gut length and pyloric caeca may influence size and quantity of food eaten. Groot (1969) and Darnell (1970) found that fishes with relatively longer guts and many caeca tended to eat smaller prey items and more frequently. In this study *L. stilbius*, with a double stomach, a long intestine, and more caeca, usually ate large quantities of small, soft foods like salps, larvaceans, and copepods, whereas *S. leucopsarus*, with its single stomach, short intestine, and fewer caeca, more often ate single euphausiids and larger copepods. The rugae and typhlosole ridges presumably help these fishes process food through the cardiac stomachs (Kapoor et al. 1975).

All aspects of alimentary morphology, therefore, indicated that *L. stilbius* is better adapted for continuously gorging itself with abundant smaller and often gelatinous prey. In contrast, *S. leucopsarus* should feed more sporadically on smaller quantities of larger prey. Indeed, *L. stilbius* tended to have "recently full" stomachs (rather than "recent but not full"), implying that it feeds mostly to fullness. *S.*

leucopsarus tended to have more "recent but not full" stomachs, implying that it feeds more sporadically and not usually to fullness.

Feeding Habits

Previous studies of food habits of bathylagids are few and sketchy. Hopkins and Torres (1989) found that *Bathylagus antarcticus* ate, among other things, gelatinous coelenterates. Anderson (1967) found that 70% of the cardiac stomachs of *L. stilbius* examined from the San Pedro Basin contained fish eggs, 60% had copepods, and 44% had fish scales, while 40% of the pyloric stomachs contained salps, 35% had copepods, 25% had euphausiids, 20% had eggs, and 20% had larvaceans. He concluded that the prey of *L. stilbius* are less mobile than those of *Triphoturus mexicanus*, a common lanternfish off southern California. Noble (1968) found similar prey but noted the dearth of fast, active chaetognaths in *L. stilbius* stomachs. All studies indicate that *L. stilbius* eats relatively small items, although our results showed that larvaceans and ostracods are more abundant food than euphausiids, at least off Santa Barbara.

Myctophids in general have been reported to eat copepods, euphausiids, ostracods, mollusks, fish eggs and larvae, chaetognaths, larval and adult decapod shrimp, insects, siphonophores, tunicates, annelids, sipunculid and nemertine larvae, pycnogonids, and foraminifera (Beebe and Vander Pyl 1944; Aughtry 1953; Paxton 1967b; Anderson 1967; Holton 1969; Legand and Rivaton 1969; Bradbury and Abbott 1970; Nakamura 1970; Raymond 1970; Baird et al. 1975a; Gorelova 1975; Hopkins and Baird 1975; Clarke 1978; Frost and McCrone 1979; Kinzer and Schultz 1985; Young and Blaber 1986; Dalpadado and Gjosaeter 1988).

Our results generally correspond with previous studies, which found that euphausiids and calanoid copepods constitute most of the *S. leucopsarus* diet (Bary et al. 1962; Osterberg et al. 1964; Paxton 1967b; Tyler and Percy 1975; Collard 1970). However, fish from the SBB ate the shrimp *Sergestes similis* much less frequently than did fish from Monterey Bay (Barham 1957), and contained fewer amphipods than fish from Saanich Inlet, British Columbia (Bary et al. 1962). No other studies reported as high a frequency of ostracods as we found in SBB fish.

L. stilbius and *S. leucopsarus* have very different feeding habits. *L. stilbius* ingests a relatively narrow variety of prey. It eats large amounts of small, slug-like, herbivorous jellies, which are 90%–95%

water (Berner 1957) and presumably not very nutritious. Optimally, it must eat continuously and digest quickly to meet its energy requirements. *L. stilbius* eats small copepods, which may be more difficult forage, only when the larvaceans and salps dwindle in numbers. *S. leucopsarus* eats a greater size range of more nutritious prey, including large predatory crustaceans.

Comparing the feeding habits of these two fishes with their growth characteristics produces an apparent paradox. Childress et al. (1980) reported a higher growth rate for *L. stilbius* than for *S. leucopsarus*, yet *L. stilbius* consumes prey of relatively lower energy content. There are three possible explanations of this paradox. One would be that *L. stilbius* grows large faster, but has tissues that are not as densely constructed (Childress and Nygaard 1973; Childress et al. 1980). A second would be that it expends less energy than *S. leucopsarus* by not regularly migrating, and by foraging more efficiently on larvaceans and salps than *S. leucopsarus* does on the larger, more elusive and vertically migrating crustaceans. A third possibility is that *L. stilbius* is more efficient at assimilating the few calories available in its prey.

Seasonal Variations in Feeding Habits

The lack of seasonal changes in eating habits and available prey in the relatively eutrophic SBB indicates that food was not limiting there. In contrast, the seasonal decrease in food (*S. fusiformis*) available to *L. stilbius* in the SCB during the late summer thermal stratification period may have forced it to seek out copepods, which may be harder to catch. The assumed decrease in primary production during this period may have caused the coincident decline in salp (and presumably larvacean) catches in the trawls, as seen by Hubbard and Percy (1971) off Oregon. These filter-feeding organisms require high concentrations of phytoplankton, and thus flourish in replenished surface waters enriched by nutrients brought up from unstratified depths (Silver 1975).

Also, in the SBB *L. stilbius* had few potential competitors, and offshore in the SCB there were only a few more. Its more oceanic relative *Bathylagus wesethi* eats larvaceans and salps (M. Kelley, pers. comm.), but almost never enters inshore waters, and invades the SCB in noticeable numbers only during the fall thermal stratification period. Even then it is far less abundant than *L. stilbius* (cf. Brown 1974). Farther offshore, however, *Bathylagus* spp. far outnumber *L. stilbius* (A. Ebeling, unpublished data). In the SCB, *Bathylagus* spp. may compete only dur-

ing the warming season, when, coincidentally, *L. stilbius* ate more copepods and fewer jellies.

Offshore, *S. leucopsarus* is probably more abundant than *L. stilbius* because it is a generalized predator and may broaden or narrow its diet as the situation demands. Its feeding habits are much more similar between basins than those of *L. stilbius*, which may have to broaden its diet beyond optimal limits in deeper waters offshore, where its preferred salps and larvaceans are not so concentrated and evenly distributed among seasons. Although *S. leucopsarus* can eat many different items both inshore and offshore, it can also feed on either euphausiids or copepods, depending on how the food supply changes. Because *S. leucopsarus* can eat just about anything it encounters, competition for items like copepods and ostracods may be less in the SBB.

The tendency, during seasons II and III, for offshore *S. leucopsarus* to eat mostly euphausiids, also observed by Collard (1970), could be explained by competition or prey availability. During these periods, myctophid competitors belonging to an "offshore fish group" (cf. Ebeling et al. 1970a) become seasonally abundant and may force *S. leucopsarus* to restrict its diet. An alternate explanation is that euphausiids may become more abundant. *S. leucopsarus* may broaden its diet to include more copepods during the cold winter season when the offshore fishes dwindle in numbers.

Diel Vertical Migrations

Even though fish abundances were standardized by trawling effort, abundances varied considerably among collections. For either species, this variability could be a function of disjunct distributions among depth zones, areas, or seasons; differences in ability to avoid the net, which is size-specific for fishes (Aron and Collard 1968); or a tendency to occur in clumps (Percy 1964; McGowan and Fraundorf 1966; Harrison 1967; Alldredge et al. 1984). Avoidance or escape may be more important during the day than at night (Percy and Laurs 1966). However, any daytime avoidance could be negated if either species is lethargic at diurnal depths, as indicated by Barham (1970), or it may be enhanced if they are hanging there but are quite ready to flee at the approach of a predator or midwater trawl (cf. Robison 1972).

Since surface waters contain more food than deep waters (Vinogradov 1974; Marshall 1954, 1980), *L. stilbius* and *S. leucopsarus*, like many other mesopelagic fishes, should benefit from regular feeding migrations toward the surface at night. They may

retreat to deeper waters during the daytime to rest, digest, and avoid predation (cf. McLaren 1963; Paxton 1967a; Nafpaktitis 1968; Marshall 1954, 1980). Indeed, the common prey of both fishes tend to inhabit the upper 400 m, and many of them migrate vertically in a diel pattern.

Several authors have observed that *L. stilbius* concentrate at mid-depth during daytime but broaden their vertical distribution by dispersing upward at night, usually not in a distinct layer (Anderson 1967; Tucker 1951; Clarke 1970; Ebeling et al. 1970b). Other authors contend, from direct observations made off San Diego from deep submersibles, that *L. stilbius* seldom ascend above 500 m and therefore do not exhibit a daily migratory pattern, but at times they do come to the surface in large numbers (Barham 1970; Pickwell et al. 1970). This somewhat unpredictable behavior helps explain the high variability in the vertical distribution data, especially in the SBB (figure 12).

To optimize its feeding strategy, *L. stilbius* must sometimes visit the surface waters where larvaceans and salps occur. Our samples indicated that most of these fish descended before daylight, although possible laggards may avoid the trawl in sunlit waters during the daytime. Our medium-speed trawls may have caught them effectively in the dark but not during the daytime. But occasionally our trawl did catch many individuals near the surface during the day. Unfortunately, few shallow hauls were made during the day in the SCB.

Many authors have noted the diel vertical migration of *S. leucopsarus*; the fish is one component of the sonic scattering layer and tends to respond to a specific isolume (Tucker 1951; Barham 1957; Fast 1960; Bary et al. 1962; Percy and Laurs 1966; Paxton 1967a; Taylor 1968; Bary and Pieper 1970; Barham 1970; Clarke 1970; Percy and Mesecar 1970; Ebeling et al. 1970a,b). Others have also noted that not all of the population ascend toward the surface waters every night (Paxton 1967b; Barham 1970; Clarke 1970; Zahuranec and Pugh 1970).

Fullness and Recency of Feeding Relative to Vertical Migration

Prey of different species are most likely digested at varying rates under different conditions (Windell 1967). In general, the stomachs of small fishes probably empty in about 12 hours (Anderson 1967; Tyler 1970). However, since all four categories of fullness and recency of feeding occurred in both species, it should not matter how long digestion takes because the recency and fullness indices will be relative. Es-

imates of how recently a particular gut was filled, however, are not possible without data on digestion rates (Hopkins and Baird 1977).

The digestibility of the common prey of *L. stilbius* may shed some light on the fullness/recency data and the feeding cycle of this species. Shelbourne (1962) observed that soft tissues of *Oikopleura* were quickly digested after capture by larval plaice. This implies that the mostly intact larvaceans in recently full stomachs of *L. stilbius* were newly ingested. In the only other study of the feeding cycle of this species, Anderson (1967) found that the guts of *L. stilbius* in the Catalina Basin were fuller with only partially digested material at night than during the day. He suggested that *L. stilbius* feeds readily at the surface at night, but he could not determine if there was much feeding at greater depths. Our relatively high percentages of "recently full" stomachs, as compared with "recent but not full" stomachs among fish caught in the surface waters indicate that *L. stilbius* feeds to fullness whenever possible.

Existing studies of *S. leucopsarus* compare favorably with ours in that the fish were found to feed mostly at night near the surface (Anderson 1967; Holton 1969). But they were also found to feed in the morning and afternoon (Paxton 1967b; Tyler and Percy 1975). However, the digestibility of prey consumed by *S. leucopsarus* must be interpreted differently. Since this fish eats mostly crustaceans, digestion may take several hours. Therefore, relatively undigested items may persist in the stomachs of deep fish that had fed earlier in shallower waters. Like *L. stilbius*, *S. leucopsarus* never had a high percentage of "full but not recent" stomachs, implying that the fish clear their stomachs rapidly. Because many of their stomachs were empty, and because their proportion of "recent but not full" stomachs often exceeded their proportion of "full and recent" stomachs for most depths, these fish may feed whenever they can, mostly on larger, less digestible items. Thus they seldom completely fill their stomachs. Also, the primary prey of *S. leucopsarus* are found between 0 and 200 m at night and between 200 and 400 m during the day (Vinogradov 1968, 1974; Youngbluth 1976; figure 19). The ultimate resolution of this question awaits an evaluation of digestion rates of mesopelagic fishes at different temperatures (Gorelova 1975; Hopkins and Baird 1977; Young and Blaber 1986; Dalpadado and Gjo-saeter 1988; Kinser and Schultz 1985).

These two midwater fishes appear to benefit from vertical migration in different ways. *L. stilbius* can occupy surface waters, either in the afternoon or at

night, where it can use its large eyes to find salps and larvaceans, and be protected from predation by its silvery coloration. The rest of the time it can find refuge from surface predators in deeper waters. *S. leucopsarus*, on the other hand, with its photophores and large mouth, most likely migrates to deeper water to seek refuge from predation, but can feed at all times and depths on copepods and co-migrating euphausiids. Thus its regular migration to the surface is not obligatory, because the fish can consume prey at any depth. Yet vertical migrations may place these fishes in surface currents that might help them find concentrations of prey (Isaacs et al. 1974).

Factors Controlling Abundance of *L. stilbius* and *S. leucopsarus*

Several possible factors may explain why *L. stilbius* is less successful offshore than *S. leucopsarus*. Both species appear to breed successfully in both places. Analysis of egg sizes versus size of females (Childress et al. 1980) indicates that both species attain sexual maturity in the two localities. Also, larvae of the two fishes occur abundantly in both basins (Ahlstrom 1965). In the SBB, 50% of all *L. stilbius* captures and 45% of all *S. leucopsarus* captures were of young (<50 mm SL) or larvae; in the SCB, the figures were 70% for *L. stilbius* and 50% for *S. leucopsarus* (Brown 1974). Ebeling et al. (1970b) also concluded that all growth stages of these two common fishes were abundant in both places.

Even though the two species differ in seasonal abundances, there is no evidence that they enter or leave the two basins at different rates. Brown (1974) reported that the more physiographically and hydrographically isolated inshore SBB restricted faunal intrusions from the offshore oceanic environment. Ebeling et al. (1970a) defined an offshore fish group consisting of "tropical" species, which increase in numbers in the SCB and farther offshore during the summer and fall when the California Current weakens. *L. stilbius* and *S. leucopsarus* co-occur with these "offshore fishes," but both species also belong to a resident "inshore" community of midwater animals, which abound in both basins throughout the year. Their otoliths, found in bottom cores (Soutar and Isaacs 1969), indicate that both species have occupied the SBB for at least 2,000 years.

Despite differences in their parasite infection rates, both species seem equally healthy and robust in the two basins. *L. stilbius* is more heavily parasitized by trematodes in the SBB than the SCB (Noble

1968; Noble and Orias 1970). *S. leucopsarus*, on the other hand, is more heavily parasitized by cestodes in the SBB but is equally infected with nematodes in both basins (Noble and Collard 1970). Our observations of parasitism concur with the above studies, and condition factors did not significantly differ within species between basins.

Predation does not seem likely to be a key factor. The same kinds of predators, with the possible exception of relatively large, deep-sea fishes such as *Chauliodus* (Borodulina 1973), occur in both places and could eat both species. It is possible that the more bathymetrically compressed SBB habitat could concentrate more predators, but there is no evidence of this.

Deepsea smelts are reportedly eaten by rockfish (Lambert 1960), albacore (McHugh 1952), and cetaceans (Fitch and Brownell 1969). In particular, *L. stilbius* is eaten by albacore and bluefin tuna (Pinkas et al. 1971). One *Chiasmodon niger*, a predatory bathypelagic fish from the San Clemente Basin, had a large adult *L. stilbius* in its distended stomach (Borodulina 1973).

Likewise, myctophids are reportedly eaten by a variety of predators, including cephalopods; large pelagic fishes such as sharks, tunas, rockfishes, and swordfish; other deep-sea fishes; sea birds; and marine mammals (e.g., Marshall 1954; Paxton 1967b; Tyler and Percy 1975; Ainley et al. 1986). In particular, *S. leucopsarus* has been eaten by sharks (Hubbs 1917), salmon (Shimada 1948), albacore and bluefin tuna (Pinkas et al. 1971), rockfishes (Eigenmann and Eigenmann 1890; Starks and Morris 1907; Pereyra et al. 1969), and cetaceans (Fitch and Brownell 1969).

It therefore seems most probable that feeding habits best account for the differential success of these two mesopelagic fishes offshore. The way in which they use the available food resources may have a great deal to do with their relative success in different habitats.

Potential Role of These Fishes in Energy Transport to the Deep Sea

In spite of their apparent lack of nutritional value, numerous midwater fishes have been reported to feed on salps and larvaceans (e.g., Gorelova 1974, 1975; Baird et al. 1975b; Kashkina 1986; Longhurst and Harrison 1988; Hopkins and Torres 1989). How these fishes utilize the gelatinous zooplankters is still uncertain. Kashkina (1986) proposed that the tunica is only partially assimilated, if at all, and it must take considerable energy for a fish to consume sufficient material to constitute a meal. On the other

hand, because salps and larvaceans filter out small particles in the water column, including phytoplankton (Silver 1975; Alldredge 1976a), and are in turn consumed by other micronekton (Alldredge 1976b; Michaels and Silver 1988), they must provide energy throughout the open water column (Morris et al. 1988). Indeed, *L. stilbius* and *S. leucopsarus*, through their consumption of salps, larvaceans, and crustaceans, and through their vertical migrations, must play an active role in transporting energy sources from the surface to deeper water (cf. Percy et al. 1977), at least in the form of fecal matter, which sinks at several cm sec^{-1} (Robison and Bailey 1981). Research is needed to determine if these fishes influence the rates of vertical flux of organic matter in the open ocean.

ACKNOWLEDGMENTS

We thank R. W. Holmes, J. H. Connell, E. R. Noble, B. Robison, and B. Nafpaktitis for critically reviewing the original manuscript. G. S. Arita, D. W. Brown, S. B. Collard, F. A. DeWitt, Jr., H. Genthe, L. Hendrian, R. M. Ibara, M. S. Love, P. Setzer, and H. Tyler helped with the field work and laboratory data analyses. R. M. Ibara and M. Palmgren wrote computer programs that helped with the statistical analyses. The University of California, Santa Barbara Computer Center provided additional computer time. This study was supported by NSF grants GB 2867 and 4698 for ship time and GB 4669 and 7973 for the shore-based analyses. A University Fellowship, University of California, Santa Barbara, provided the senior author with one year of support.

LITERATURE CITED

- Ahlstrom, E. H. 1965. Evaluation of fishes resources of the Pt. Arguello area. Part I. Fish larvae of the Pt. Arguello area. Report AT (49-7)-2428, Division of Biology and Medicine, U.S. Atomic Energy Commission.
- . 1969. Mesopelagic and bathypelagic fishes in the California Current Region. Calif. Coop. Oceanic Fish. Invest. Rep. 13: 39-44.
- Ainley, D. G., W. R. Fraser, C. W. Sullivan, J. J. Torres, T. L. Hopkins, and W. O. Smith. 1986. Antarctic mesopelagic micronekton: evidence from sea birds that pack ice affects community structure. *Science* 232: 847-849.
- Alexander, R. M. 1967. Functional design in fishes. London: Hutchinson and Co., 164 pp.
- Allredge, A. L. 1967a. Appendicularians. *Sci. Am.* 235(1):94-102.
- . 1976b. Discarded appendicularian houses as sources of food, surface habitats, and particulate organic matter in planktonic environments. *Limnol. Oceanogr.* 21(1):14-23.
- . 1976c. Field behavior and adaptive strategies of appendicularians (Chordata: tunicata). *Mar. Biol.* 38:29-39.
- Allredge, A. L., B. H. Robison, A. Fleminger, J. J. Torres, J. M. King, and W. M. Hamner. 1984. Direct sampling and in situ observation of a persistent copepod aggregation in the mesopelagic zone of the Santa Barbara Basin. *Mar. Biol.* 80:75-81.

- Anderson, R. 1967. Feeding chronology in two deep-sea fishes off California. M. S. thesis, University of Southern California.
- Aron, W. I., and S. B. Collard. 1968. A study of the influence of net speed on catch. *Limnol. Oceanogr.* 14:242-249.
- Aron, W. I., N. Raxter, R. Noel, and W. Andrews. 1964. A description of a discrete depth plankton sampler with some notes on the towing behavior of a 6-foot Isaacs-Kidd midwater trawl and a 1-m ring net. *Limnol. Oceanogr.* 9:324-333.
- Aughtry, R. H. 1953. A note on the mass mortality of the myctophid fish *Tarletonbeania crenularis*. *Copeia* 1953(3):190-192.
- Baird, R. C., T. L. Hopkins, and D. F. Wilson. 1975a. Diet and feeding chronology of *Diaphus taaningi* (Myctophidae) in the Cariaco Trench. *Copeia* 1975(2):356-365.
- Baird, R. C., N. P. Thompson, T. L. Hopkins, and W. R. Weiss. 1975b. Chlorinated hydrocarbons in mesopelagic fishes of the eastern Gulf of Mexico. *Bull. Mar. Sci.* 25(4):473-481.
- Barham, E. G. 1957. The ecology of sonic scattering layers in the Monterey Bay area. Stanford University, Hopkins Mar. Sta. Tech. Rep. 1:1-182.
- . 1970. Deep-sea fishes: lethargy and vertical orientation. *In Proc. Internat. Symp. Biol. Sound Scattering in the Ocean*, G. B. Farquhar, ed. Maury Center Ocean Sci., Washington, D.C. No. 5, pp. 101-119.
- Bary, B. M., and R. E. Pieper. 1970. Sonic-scattering studies in Saanich Inlet, British Columbia: a preliminary report. *In Proc. Internat. Symp. Biol. Sound Scattering in the Ocean*, G. B. Farquhar, ed. Maury Center Ocean Sci., Washington, D.C. No. 5, pp. 601-611.
- Bary, B. M., W. E. Barraclough, and R. Herlinveaux. 1962. Scattering of underwater sound in Saanich Inlet, British Columbia. *Nature* 194:36-37.
- Beebe, W., and M. Vander Pyl. 1944. Eastern Pacific Expeditions of the New York Zoological Society. XXXIII. Pacific Myctophidae (fishes). *Zoologica* 29:59-95.
- Berner, L. D., Jr. 1957. Studies on the Thaliacea of the temperate north-east Pacific Ocean. Ph.D. thesis, University of California, Los Angeles.
- . 1967. Distributional atlas of Thaliacea in the California Current region. *Calif. Coop. Oceanic Fish. Invest. Atlas* (8):1-322.
- Berry, F. H. 1964. Aspects of the development of the upper jaw bones in teleosts. *Copeia* 1964(3):375-384.
- Bolin, R. 1939. A review of the myctophid fishes of the Pacific coast of the United States and of lower California. *Stanford Ichthyol. Bull.* 1:89-156.
- Borodulina, O. D. 1968. Taxonomy and distribution of the genus *Leuroglossus* (Bathylagidae, Pisces.) *Prob. Ichthyol.* 8:1-10.
- . 1973. The feeding of mesopelagic predatory fish in the open ocean. *J. Ichthyology, Acad. Sci. USSR* 12(4):692-702.
- Bourbeau, F., W. D. Clarke, and W. Aron. 1966. Improvements in the discrete depth plankton sampler system. *Limnol. Oceanogr.* 11:422-426.
- Bradbury, M. G., and D. P. Abbott. 1970. Studies on the fauna associated with the deep scattering layers in the equatorial Indian Ocean, conducted on R/V Te Vega during October and November 1964, *In Proc. Internat. Symp. Biol. Sound Scattering in the Ocean*, G. B. Farquhar, ed. Maury Center Ocean Sci., Washington, D.C. No. 5, pp. 409-452.
- Brown, D. W. 1974. Hydrography and midwater fishes of three contiguous oceanic areas off Santa Barbara, California. *Nat. Hist. Mus., Los Angeles Co., Contrib. Sci.* (261):1-30.
- Cailliet, G. M., M. S. Love, and A. W. Ebeling. 1986. Fishes: a field and laboratory manual on their structure, identification, and natural history. Belmont, California: Wadsworth Publishing Co., 194 pp.
- Chapman, W. M. 1943. The osteology and relationships of the bathypelagic fishes of the genus *Bathylagus* Gunther with notes on the systematic position of *L. stilbius* Gilbert and *Therobromus callorhinus* Lucas. *J. Wash. Acad. Sci.* 33:147-160.
- Childress, J. J., and M. H. Nygaard. 1973. The chemical composition of midwater fishes as a function of depth of occurrence off southern California. *Deep-Sea Res.* 20:1093-1109.
- Childress, J. J., S. M. Taylor, G. M. Cailliet, and M. H. Price. 1980. Patterns of growth, energy utilization and reproduction in some meso- and bathypelagic fishes off southern California. *Mar. Biol.* 61:27-40.
- Clarke, T. A. 1978. Diel feeding patterns of 16 species of mesopelagic fishes from Hawaiian waters. *Fish. Bull.* 76(3):495-513.
- Clarke, W. D. 1970. Comparison of different investigative techniques for studying the deep scattering layers. *In Proc. Internat. Symp. Biol. Sound Scattering in the Ocean*, G. B. Farquhar, ed. Maury Center Ocean Sci., Washington, D.C. No. 5, pp. 551-562.
- Collard, S. B. 1970. Forage of some eastern Pacific midwater fishes. *Copeia* 1970(2):348-354.
- Dalpadado, P., and J. Gjosaeter. 1988. Feeding ecology of the lanternfish *Benthosema pterotum* from the Indian Ocean. *Mar. Biol.* 99:555-567.
- Darnell, R. M. 1970. Evolution and the ecosystem. *Am. Zool.* 10:9-17.
- Ebeling, A. W., G. M. Cailliet, R. M. Ibara, F. A. DeWitt, Jr., and D. W. Brown. 1970a. Pelagic communities and sound scattering off Santa Barbara, California. *In Proc. Internat. Symp. Biol. Sound Scattering in the Ocean*, G. B. Farquhar, ed. Maury Center Ocean Sci., Washington, D.C. No. 5, pp. 1-19.
- Ebeling, A. W., R. M. Ibara, R. J. Lavenberg, and F. J. Rohlf. 1970b. Ecological groups of deep-sea animals off southern California. *Bull. Los Angeles Co. Mus. Nat. Hist., Science* (6):1-43.
- Eigenmann, C. H., and R. S. Eigenmann. 1890. Additions to the fauna of San Diego. *Proc. Calif. Acad. Sci.* 2(3):1-24.
- Emery, K. O. 1960. The sea off southern California. New York: John Wiley, 336 pp.
- Eschmeyer, W. N., E. S. Herald, and H. Hammann. 1983. A field guide to Pacific coast fishes of North America. Boston: Houghton Mifflin Company, 336 pp.
- Fager, E. W. 1972. Diversity: a sampling study. *Am. Nat.* 106:293-310.
- Fast, T. N. 1960. Some aspects of the natural history of *Stenobrachius leucopsarus* Eigenmann and Eigenmann. Ph.D. thesis, Stanford University.
- Fitch, J., and R. L. Brownell, Jr. 1969. Fish otoliths in cetacean stomachs and their importance interpreting feeding habits. *J. Fish. Res. Bd. Can.* 25:2561-2574.
- Frost, B. W., and L. E. McCrone. 1979. Vertical distribution, diel vertical migration, and abundance of some mesopelagic fishes in the eastern subarctic Pacific Ocean in summer. *Fish. Bull.* 76(4):717-749.
- Gorelova, T. A. 1974. Zooplankton organisms from the stomachs of lantern-fish juveniles of the family Myctophidae (in Russian; English abstract). *Okeanologia* 14(4):713-718.
- . 1975. The feeding of fishes of the family Myctophidae. *J. Ichthyol.* 15(2):208-219.
- Groot, S. J. de. 1969. Digestive system and sensorial factors in relation to the feeding behaviour of flatfish (Pleuronectiformes). *J. Conseil* 32:385-395.
- Harrison, C. M. H. 1967. On methods for sampling mesopelagic fishes. *In Symp. Zool. Soc. London*, pp. 71-126.
- Hart, J. L. 1973. Pacific fishes of Canada. *Fish. Res. Bd. Can. Bull.* (180) 740 pp.
- Holton, A. A. 1969. Feeding behavior of a vertically migrating lanternfish. *Pac. Sci.* 23:325-331.
- Hopkins, T. L., and R. C. Baird. 1975. Net feeding in mesopelagic fishes. *Fish. Bull.* 73(4):908-914.
- . 1977. Aspects of the feeding ecology of oceanic midwater fishes. *In Oceanic sound scattering prediction*, N. R. Andersen and B. J. Zahuranec, eds. New York: Plenum Press, pp. 325-360.
- Hopkins, T. L., and J. J. Torres. 1989. Midwater food web in the vicinity of a marginal ice zone in the western Weddell Sea. *Deep-Sea Res.* 36(4):543-560.
- Hubbard, L. T., and W. G. Percy. 1971. Geographic distribution and relative abundance of Salpidae off the Oregon coast. *J. Fish. Res. Bd. Can.* 28:1831-1836.
- Hubbs, C. L. 1917. A note on the food of *Squalus sucklii*, the Californian dogfish. *Copeia* 1917(3):37-38.
- Isaacs, J. D., S. A. Tont, and G. L. Wick. 1974. Deep scattering layers: vertical migration as a tactic for finding food. *Deep-Sea Res.* 21:651-656.

- Jollie, M. T. 1954. General anatomy of *Lampanyctus leucopsarus* (Eigenmann and Eigenmann). Ph.D. thesis, Stanford University.
- Jones, J. H. 1971. General circulation and water characteristics in the Southern California Bight. Rep. Calif. Coastal Water Res. Project, Los Angeles, California.
- Kapoor, B. G., H. Smit, and I. A. Verighina. 1975. The alimentary canal and digestion in teleosts. *Adv. Mar. Biol.* 13:109-239.
- Kashkina, A. A. 1986. Feeding of fishes on salps (Tunicata, Thaliacea). *Voprosy Ikhtiologii* (3):440-447. Translated in 1987 by Scripta Technica, Inc. ISSN0032-9452/86/0004-0057.
- Kinzer, J., and K. Schulz. 1985. Vertical distribution and feeding patterns of midwater fish in the central equatorial Atlantic. I. Myctophidae. *Mar. Biol.* 85:313-322.
- Lambert. 1960. The food of the redfish *Sebastes marinus* (L.) in the Newfoundland area. *J. Fish. Res. Bd. Can.* 17:235-243.
- Lancraft, T. M., and B. H. Robison. 1980. Evidence of post-capture ingestion by midwater fishes in trawl nets. *Fish. Bull.* 77(3):713-715.
- Lavenberg, R. J., and A. W. Ebeling. 1967. Distribution of midwater fishes among deep-water basins of the southern California shelf. *In Proc. Symp. Biol. Calif. Islands*, Santa Barbara Botanic Garden, R. M. Philbrick, ed. Pp. 185-201.
- Legand, M., and J. Rivaton. 1969. Cycles biologiques des poissons mesopelagiques de l'est de l'Océan Indien. Troisième note: action prédatrice des poissons micronectoniques. *Cah. ORSTOM (ser. Oceanogr.)* 7:29-45.
- Longhurst, A. R. 1967. Diversity and trophic structure of zooplankton communities in the California Current. *Deep-Sea Res.* 14:393-408.
- Longhurst, A. R., and W. G. Harrison. 1988. Vertical nitrogen flux from the oceanic photic zone by diel migrant zooplankton and nekton. *Deep-Sea Res.* 35(6):881-889.
- MacArthur, R. H., and J. H. Connell. 1966. The biology of populations. New York: John Wiley, 200 pp.
- Malone, T. C. 1971. The relative importance of nannoplankton and netplankton as primary producers in the California Current system. *Fish. Bull.* 69:799-820.
- Marshall, N. B. 1954. Aspects of deep-sea biology. London: Hutchinson, 379 pp.
- . 1980. Deep-sea biology: developments and perspectives. New York: Garland STPM Press, 566 pp.
- Martin, N. V., and F. K. Sandercock. 1967. Pyloric caeca and gill raker development in lake trout, *Salvelinus namaycush*, in Algonquin Park, Ontario. *J. Fish. Res. Bd. Can.* 24:965-974.
- McAllister, D. E. 1961. A collection of oceanic fishes from off British Columbia with a discussion of the evolution of black peritoneum. *Bull. Nat. Mus. Can.* 172:39-43.
- McGowan, J. A., and V. J. Fraundorf. 1966. The relationship between size of net used and estimates of zooplankton diversity. *Limnol. Oceanogr.* 11:456-469.
- McHugh, J. L. 1952. The food of albacore (*Germo alalunga*) off California and Baja California. *Bull. Univ. Calif. Scripps Inst. Oceanogr.* 6:161-172.
- McLaren, I. A. 1963. Effects of temperature on growth of zooplankton, and the adaptive value of vertical migration. *J. Fish. Res. Bd. Can.* 20:685-727.
- Michaels, A. F., and M. W. Silver. 1988. Primary production, sinking fluxes and the microbial food web. *Deep-Sea Res.* 35(4):473-490.
- Miller, D. J., and R. N. Lea. 1972. Guide to the coastal marine fishes of California. *Calif. Fish Game, Fish Bull.* 157:1-235.
- Morris, R. J., Q. Bone, R. Head, J. C. Braconnot, and P. Nival. 1988. Role of salps in the flux of organic matter to the bottom of the Ligurian Sea. *Mar. Biol.* 97(2):237-242.
- Nafpaktitis, B. G. 1968. Taxonomy and distribution of the lanternfishes, genera *Lobianchia* and *Diaphus*, in the North Atlantic. *Dana-Rept.* 73:1-131.
- Nakamura, E. L. 1970. Observations on the biology of the myctophid *Diaphus garmani*. *Copeia* 1970(2):374-377.
- Noble, E. R. 1968. The flagellate *Cryptobia* in two species of deep sea fishes from the eastern Pacific. *J. Parasit.* 54:720-724.
- Noble, E. R., and S. B. Collard. 1970. The parasites of midwater fishes. *In A symposium on diseases of fishes and shellfishes*, S. Sniesko, ed. Spec. Publ. Am. Fish. Soc. No. 5, p. 570-68.
- Noble, E. R., and J. D. Orias. 1970. The trematode *Aponurus californicus* n. sp. and its host, the deep-sea smelt, *Leuroglossus stilbius*. *Trans. Am. Microsc. Soc.* 89:413-417.
- Osterberg, C., W. G. Percy, and H. Curl, Jr. 1964. Radioactivity and its relationship to oceanic food chains. *J. Mar. Res.* 22:2-12.
- Paxton, J. R. 1967a. A distributional analysis for the lanternfishes (Family Myctophidae) of the San Pedro Basin, California. *Copeia* 1967(2):422-440.
- . 1967b. Biological notes on southern California lanternfishes (Family Myctophidae). *Calif. Fish Game* 53:214-217.
- Percy, W. G. 1964. Some distributional features of mesopelagic fishes off Oregon. *J. Mar. Res.* 22:83-102.
- . 1976. Seasonal and inshore-offshore variations in the standing stocks of micronekton and macrozooplankton off Oregon. *Fish. Bull.* 74(1):70-80.
- Percy, W. G., and R. M. Laurs. 1966. Vertical migration and distribution of mesopelagic fishes off Oregon. *Deep-Sea Res.* 13:153-165.
- Percy, W. G., and R. S. Mesecar. 1970. Scattering layers and vertical distribution of oceanic animals off Oregon. *In Proc. Internat. Symp. Biol. Sound Scattering in the Ocean*, G. B. Farquhar, ed. Maury Center Ocean Sci., Washington, D.C. No. 5, pp. 381-394.
- Percy, W. G., E. E. Krygier, and N. H. Cutshall. 1977. Biological transport of zinc-65 into the deep sea. *Limnol. Oceanogr.* 22(5):846-855.
- Pereyra, W. T., W. G. Percy, and F. E. Carvey, Jr. 1969. *Sebastes flavidus*, a shelf rockfish feeding on mesopelagic fauna, with consideration of the ecological implications. *J. Fish. Res. Bd. Can.* 25:2211-2215.
- Pickwell, G. V., R. J. Vent, E. G. Barham, W. E. Batzler, and I. E. Davies. 1970. Biological acoustical scattering off southern California, Baja California, and Guadalupe Island. *In Proc. Internat. Symp. Biol. Sound Scattering in the Ocean*, G. B. Farquhar, ed. Maury Center Ocean Sci., Washington, D.C. No. 5, pp. 490-507.
- Pinkas, L., M. S. Oliphant, and I. L. K. Iverson. 1971. Food habits of albacore, bluefin tuna, and bonito in California waters. *Calif. Fish Game, Fish Bull.* 152:1-105.
- Raymont, J. E. G. 1970. Problems of the feeding of zooplankton in the deep sea. *In Proc. Internat. Symp. Biol. Sound Scattering in the Ocean*, G. B. Farquhar, ed. Maury Center Ocean. Sci., Washington, D.C. No. 5, pp. 136-148.
- Robison, B. H. 1972. Distribution of the midwater fishes of the Gulf of California. *Copeia* 1972(3):448-461.
- Robison, B. H., and T. G. Bailey. 1981. Sinking rates and dissolution of midwater fish fecal matter. *Mar. Biol.* 65:135-142.
- Shelbourne, J. E. 1962. A predator-prey size relationship for plaice larvae feeding on *Oikopleura*. *J. Mar. Biol. Assn. U.K.* 42:243-252.
- Shimada, B. M. 1948. Records of lanternfish in Puget Sound. *Copeia* 1948(3):227.
- Sholkovitz, E. R., and J. M. Gieskes. 1971. A physical-chemical study of the flushing of the Santa Barbara Basin. *Limnol. Oceanogr.* 16:479-489.
- Silver, M. 1975. The habitat of *Salpa fusiformis* in the California Current as defined by indicator assemblages. *Limnol. Oceanogr.* 20(2):230-237.
- Sokal, R. R., and F. J. Rohlf. 1969. *Biometry*. San Francisco: W. H. Freeman and Co. 776 pp.
- Soutar, A., and J. D. Isaacs. 1969. History of fish populations inferred from fish scales in anaerobic sediments off California. *Calif. Coop. Oceanic Fish. Invest. Rep.* 13:63-70.
- Starks, E. C., and E. L. Morris. 1907. The marine fishes of southern California. *Univ. Calif. Publ. Zool.* 3:159-251.
- Taylor, F. H. C. 1968. The relationship of midwater trawl catches to sound scattering layers off the coast of northern British Columbia. *J. Fish. Res. Bd. Can.* 25:457-472.
- Tucker, G. 1951. Relations of fishes and other organisms to the scattering of underwater sound. *J. Mar. Res.* 10:215-238.
- Tyler, A. V. 1970. Rates of gastric emptying in young cod. *J. Fish. Res. Bd. Can.* 27:1177-1189.
- Tyler, H. R., and W. G. Percy. 1975. The feeding habits of three species of lanternfishes (Family myctophidae) off Oregon, USA. *Mar. Biol.* 32:7-11.

- Vinogradov, M. E. 1968. Vertical distribution of the oceanic zooplankton. Israel Program for Sci. Transl., Jerusalem (1970), 330 pp.
- . 1974. Depth of the nighttime rise of deep scattering layers in the central Pacific. *Oceanology* 14(6):891–895 (Translated by Scripta Technica, Inc. for the Am. Geophys. Union).
- Willis, J. M., and W. G. Percy. 1980. Spatial and temporal variations in the population size structure of three lanternfishes (Myctophidae) off Oregon, USA. *Mar. Biol.* 57:181–191.
- Windell, J. T. 1967. Rates of digestion in fishes. *In* The biological basis of freshwater fish production, S. Gerking, ed. New York: John Wiley, pp. 151–173.
- Yasuda, F. 1960a. The feeding mechanism in young fishes. *Rec. Oceanogr. Works Japan* 5:132–138.
- . 1960b. The feeding mechanisms in some carnivorous fishes. *Rec. Oceanogr. Works Japan* 5:153–160.
- . 1960c. The relationship of the gill structure and food habits of some coastal fishes in Japan. *Rec. Oceanogr. Works Japan* 5:139–152.
- Yasuda, F., and Y. Hiyama. 1957. Mechanism of utilization of plankton by some fishes. *Rec. Oceanogr. Works Japan* 3:85–91.
- Young, J. W., and S. J. M. Blaber. 1986. Feeding ecology of three species of midwater fishes associated with the continental slope of eastern Tasmania, Australia. *Mar. Biol.* 93:147–156.
- Youngbluth, M. J. 1976. Vertical distribution and diel migration of euphausiids in the central region of the California Current. *Fish. Bull.* 74(4):925–936.
- Zahuranec, B. J., and W. L. Pugh. 1970. Biological results from scattering layer investigations in the Norwegian Sea. *In* Proc. Internat. Symp. Biol. Sound Scattering in the Ocean, G. B. Farquhar, ed. Maury Center Ocean Sci., Washington, D.C. No. 5, pp. 360–380.