

---

***HMP45A&HMP45D  
HUMIDITY AND  
TEMPERATURE PROBES  
Operating Manual***

U274en-1.2  
29 September 1997  
© Vaisala 1997

© Vaisala Oy 1997

No part of this document may be reproduced in any form or by any means, electronic or mechanical (including photocopying), nor may its contents be communicated to a third party without a prior written notice of the copyright holder.

The instruction manuals may be changed without prior notice.

## 1. GENERAL

The HMP45A and HMP45D probes are designed for the measurement of relative humidity and temperature. Humidity measurement is based on the capacitive thin film polymer sensor HUMICAP®180. Temperature measurement is based on resistive platinum sensors (Pt 100 and Pt 1000). Both the humidity and temperature sensors are located at the tip of the probe and in standard version protected by a membrane filter. The HMP45A and HMP45D have a similar humidity output, but the temperature output is active in HMP45A (voltage output 0-1V) and passive in HMP45D (resistive output Pt 100).

## 2. CONNECTIONS

The cable wires are connected as shown in Figure 1.

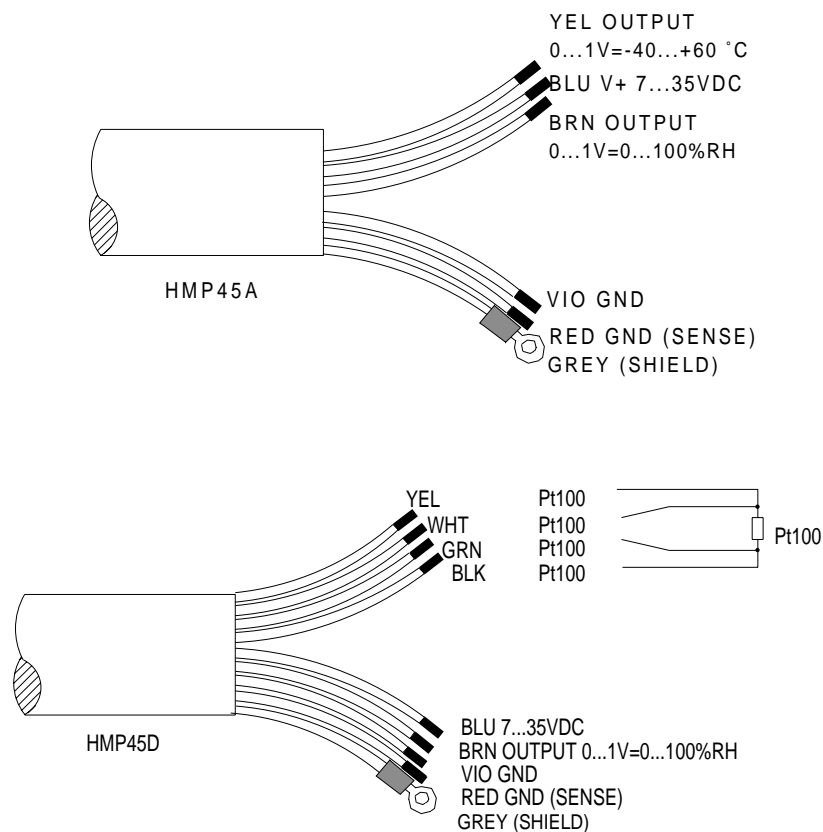

**Figure 1 Wire colours**

SIGNAL GROUND is used for output signal in a differential measurement. With SIGNAL GROUND, the cable can be extended up to 100 metres without disturbing the measurement accuracy. When outputs are not measured against SIGNAL GROUND, connect GROUND and SIGNAL GROUND to the same point.

### 3. CALIBRATION AND MAINTENANCE

Calibration and maintenance of the probes should be performed at regular intervals, depending on the conditions of use and desired accuracy. The recommended calibration interval is one year.

The HMP45A/D probes are easy to maintain and calibrate. The probe consists of a probe head and a handle with cable. All calibration electronics are in the probe head which can be disconnected from the handle without disconnecting the wires (see Figure 2). The handles of all HMP45A and HMP45 probes are fully interchangeable. If you wish to continue the measurement immediately, you can insert a calibrated probe head in place of the disconnected one; this way, the measurement is interrupted for less than a minute.

#### 3.1 Reading the outputs during calibration

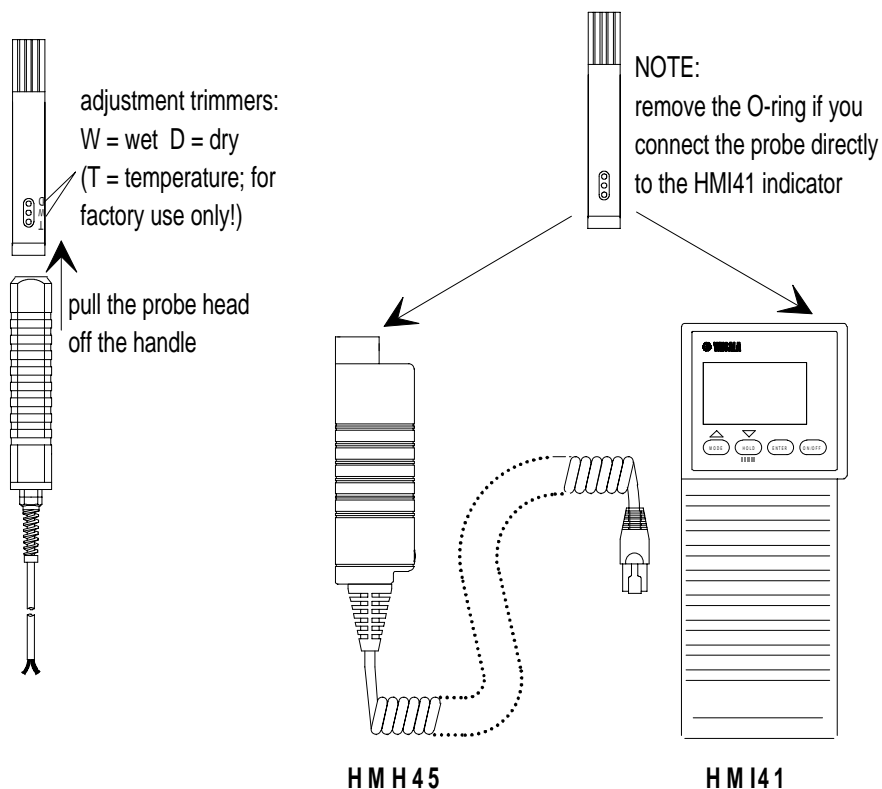

**Figure 2 Adjustment trimmers and probe head connection/disconnection**

In calibration, the HMP45A/D output is normally read from the output cables. The HMP45A probe head can also be checked with Vaisala's HMI41 indicator (see Figure 2); the probe head can be connected either to the HMH45 handle, or directly to the HMI41 indicator. However, note that if you connect the probe head directly to the HMI41, you must first remove the O-ring. Measured humidity and temperature appear on the HMI41 display.

A simple field check can also be performed when there seems to be something wrong with the measurement system. It is sufficient to compare the HMP45A

reading with the reading measured by a calibrated reference probe head. Check the ambient relative humidity and temperature level with the reference probe head, and then connect the HMP45A probe head on the HMI41 handle and check the output readings.

Prepare the HMI41 indicator for measurements with the HMP45A probe head as follows: turn the HMI41 indicator on and within 1-2 seconds press simultaneously buttons ENTER and MODE until the text **SEtUP** appears on the display.

Wait a few seconds, and the text **Unit** appears; press ENTER repeatedly until a text similar to the following appears on the display:

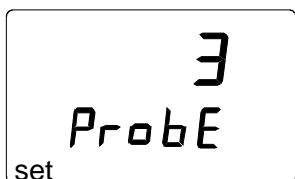

Select **PROBE TYPE 3** with buttons ▲ (number up) or ▼ (number down) and turn the indicator off. Turn it on again by pressing the ON/OFF button. After a few seconds, the relative humidity and temperature readings appear automatically on the display.

The HMP45D cannot be used with the HMI41 indicator as the passive temperature signal results in error messages on the HMI41.

### 3.2 Humidity calibration

For a high-accuracy two-point calibration use a Vaisala HMK15 or HMK13B calibrator and saturated salt solutions as described in the respective manuals.

Leave the calibrator, the HMI41 and the probe head in the same space for at least four hours so that their temperatures have time to equalize. Unscrew the plastic grid of the probe.

The calibration is done first for the dry end and then for the wet end by adjusting trimmer potentiometers marked “D” (dry, <50 %RH) and “W” (wet, >50 %RH). The potentiometers are located under a protective plug; see Figure 2. Use a ceramic screw driver with 2.5 mm blade for adjusting the potentiometers. Note: if zero point is calibrated in Nitrogen (N<sub>2</sub>), the minimum output signal of 0.008 V corresponds to a relative humidity of 0.8 %RH.

#### Greenspan’s calibration table

Temperature	°C	15	20	25	30	35
-------------	----	----	----	----	----	----

LiCl	%RH	*)	11.3	11.3	11.3	11.3
NaCl	%RH	75.6	75.5	75.3	75.1	74.9
K <sub>2</sub> SO <sub>4</sub>	%RH	97.9	97.6	97.3	97.0	96.7

\*) Do not use or store the LiCl solution in temperatures below +18°C as its humidity equilibrium may change permanently

As the D (dry) and W (wet) adjustments may affect each other, check again the humidity reading at the low end. If necessary, repeat the adjustments in both the low and the high humidity points until the reading is correct.

### 3.3 Changing the HUMICAP®180 humidity sensor

Unscrew the filter. Remove the damaged sensor and mount a new HUMICAP®180 humidity sensor in its place. Handle the sensor with care. Calibrate the probe using a two-point calibration procedure. Note that if the probe is not calibrated, the accuracy is still better than ±7 %RH.

## 4. SPARE PARTS AND ACCESSORIES

Order code	Description
HUMICAP®180	Humidity sensor
18921	Temperature sensor Pt 1000 IEC 751 1/3 Class B (HMP45A)
19159	Temperature sensor Pt 100 IEC 751 1/3 Class B (HMP45D)
2787HM	Membrane filter (standard)
6685	Sintered filter 37 µm
6686	Sintered filter 216 µm
6597	Plastic grid
HMP45ASP	HMP45A probe head
HMP45DSP	HMP45D probe head
HMH45ASP	Probe handle for HMP45A and HMP45D
HMI41	Humidity and temperature indicator
HMH45	Probe handle for HMP45A with a connector to HMI41
HMK11	Humidity Calibrator
HMK13B	Humidity Calibrator

## 5. TECHNICAL DATA

### 5.1 Humidity (HMP45A & HMP45D)

Measurement range 0.8...100 %RH  
 Output scale 0...100 %RH equals 0-1 VDC  
 Accuracy at +20 °C (including non-linearity and hysteresis):

against factory references	$\pm 1$ %RH
field calibration against references	$\pm 2$ %RH (0...90 %RH) $\pm 3$ %RH (90...100 %RH)
Typical long-term stability	better than 1 %RH per year
Temperature dependence	$\pm 0.05$ %RH/°C
Response time (90%) at +20 °C	15 s with membrane filter
Humidity sensor	HUMICAP®180

## 5.2 Temperature

### HMP45A

Measurement range	-39.2...+60 °C
Output scale	-40...+60 °C equals 0...1 VDC
Accuracy at 20°C	$\pm 0.2$ °C
Accuracy over the whole measurement range:	

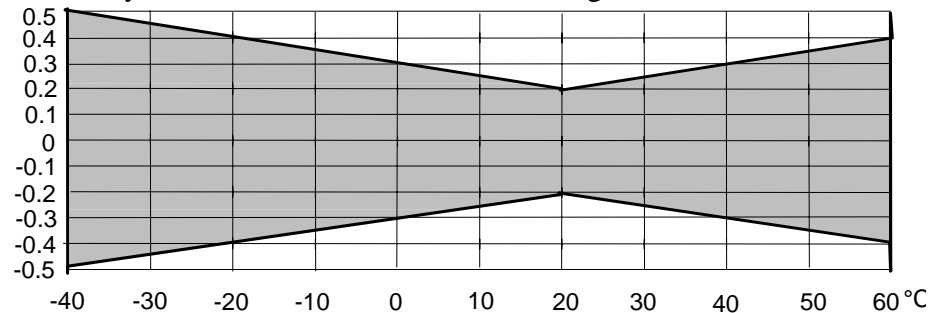

Temperature sensor	Pt 1000 IEC 751 1/3 Class B
--------------------	-----------------------------

### HMP45D

Measurement range	-40...+60 °C
Output signal	resistive four wire connection
Temperature sensor	Pt 100 IEC 751 1/3 Class B

## 5.3 General

Operating temperature range	-40...+60 °C
Storage temperature range	-40...+80 °C
Supply voltage	7...35 VDC
Settling time	500 ms
Power consumption	< 4 mA
Output load	>10 kohm (to ground)
Weight	350 g (including package)
Cable length	3.5 m
Housing material	ABS plastic
Housing classification (electronics)	IP 65 (NEMA 4)
Sensor protection (standard)	membrane filter, part no. 2787HM

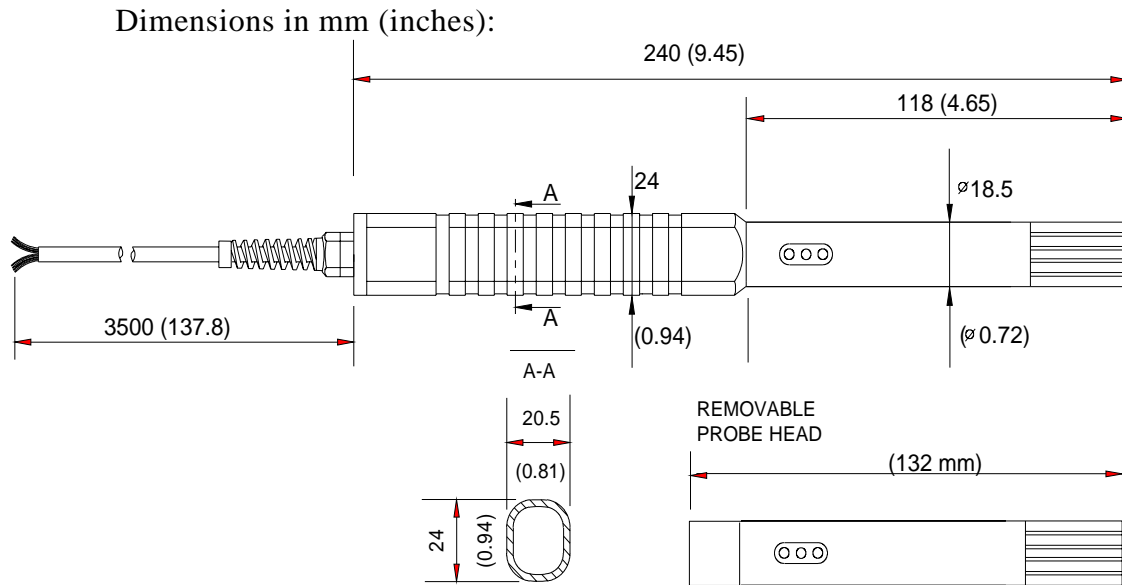

## 5.4 Electromagnetic compatibility

### 5.4.1 Emissions

Radiated interference, test setup according to EN55022

### 5.4.2 Immunity

Test:	Test setup according to:	Performance:
Radiated interference	IEC 1000-4-3	HMP45A level 1 (3V/m) HMP45D level 3 (10 V/m)
Electrostatic discharge	IEC 801-4	level 4 (HMP45A&D)



## GUARANTEE

Vaisala issues a guarantee for the material and workmanship of this product for one (1) year from the date of delivery. Damage due to exceptional operating conditions, careless handling or misapplication will void the guarantee. Detailed warranty information is given in the Warranty and the Standard Conditions of Sale of Vaisala Oy.