

### ***For high accuracy infrared radiation measurement research***

The CG4 is designed for high accuracy infrared (IR) meteorological measurement research, for both sky and surface emitted infrared radiation, from 4.5 to 42  $\mu\text{m}$

The CG4 provides a voltage output signal that is proportional to either the incoming sky, or surface emitted IR, depending on instrument mode of operation. The amount of IR can be derived through calculation, in  $\text{W}/\text{m}^2$  units. The design of the CG4 therefor employs a single YSI 10K  $\Omega$  body thermistor, in addition to the instruments thermopile sensing element.

The CG4 features a specially designed ellipse shaped solar blind silicon dome, that offers a full 180° field of view, and with good cosine response. A hard carbon (diamond) coating on the domes outer surface protects against surface oxidation and scratching.

Absorbed direct solar heat load by the dome is effectively conducted away by a unique dome ring construction. Even under direct solar load conditions, CG4 dome temperature rise (relative to ambient case temperature) is negligible. This allows for accurate daytime measurements without the use of a tracking shading disc, and eliminates the need for window heating compensation.

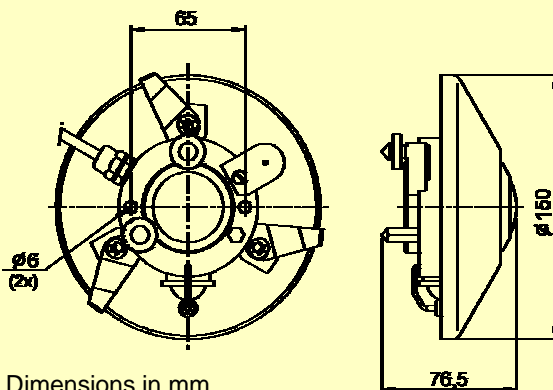

Dimensions in mm.

| <b>Specifications</b>            |   |
|----------------------------------|---|
| Sensitivity (nominal)            | 10 $\mu\text{V}/\text{Wm}^{-2}$   |
| Spectral range                   | 4.5 – 42 $\mu\text{m}$  |
| Window heating offset            | < 4 $\text{W}/\text{m}^2$ at 1000 $\text{W}/\text{m}^2$ solar radiation |
| Operating temperature            | -40°C to +80°C  |
| Response time (63%)              | less than 8 sec   |
| Thermopile output range          | -250 to +250 $\text{W}/\text{m}^2$                                      |
| Temperature dependence           | < $\pm 1\%$ (-20°C to +50°C)  |
| Zero offset due to temp. changes | < 2 $\text{W}/\text{m}^2$ (5K/h)  |
| Field of view                    | 180°  |

