

# INSTRUCTION MANUAL



## **R.M. Young Wind Monitors**

**05103, 05103-10**

**05305, 05305-10**

**05106, 05106-10**

**05106C, 05106C-10**

Revision: April 2009



Copyright © 2005-2006  
Campbell Scientific (Canada) Corp.

## WARRANTY AND ASSISTANCE

This equipment is warranted by CAMPBELL SCIENTIFIC (CANADA) CORP. ("CSC") to be free from defects in materials and workmanship under normal use and service for **twelve (12) months** from date of shipment unless specified otherwise. \*\*\*\*\* **Batteries are not warranted.** \*\*\*\*\* CSC's obligation under this warranty is limited to repairing or replacing (at CSC's option) defective products. The customer shall assume all costs of removing, reinstalling, and shipping defective products to CSC. CSC will return such products by surface carrier prepaid. This warranty shall not apply to any CSC products which have been subjected to modification, misuse, neglect, accidents of nature, or shipping damage. This warranty is in lieu of all other warranties, expressed or implied, including warranties of merchantability or fitness for a particular purpose. CSC is not liable for special, indirect, incidental, or consequential damages.

Products may not be returned without prior authorization. To obtain a Return Merchandise Authorization (RMA), contact CAMPBELL SCIENTIFIC (CANADA) CORP., at (780) 454-2505. An RMA number will be issued in order to facilitate Repair Personnel in identifying an instrument upon arrival. Please write this number clearly on the outside of the shipping container. Include description of symptoms and all pertinent details.

CAMPBELL SCIENTIFIC (CANADA) CORP. does not accept collect calls.

Non-warranty products returned for repair should be accompanied by a purchase order to cover repair costs.



**CAMPBELL SCIENTIFIC**  
C A N A D A C O R P .

11564 - 149 street - edmonton - alberta - T5M 1W7  
tel 780.454.2505 fax 780.454.2655

[www.campbellsci.ca](http://www.campbellsci.ca)

# Table of Contents

---

*PDF viewers note: These page numbers refer to the printed version of this document. Use the Adobe Acrobat® bookmarks tab for links to specific sections.*

<b>1. General Description</b> .....	1
<b>2. Specifications</b> .....	2
<b>3. Installation</b> .....	4
<b>4. Wiring</b> .....	5
<b>5. Example Programs</b> .....	6
5.1 Wind Speed .....	6
5.2 Wind Direction .....	7
5.3 Wind Vector Processing Instruction .....	8
5.4 Example Programs.....	8
5.4.1 CR10X Example Program .....	8
5.4.2 CR1000 Example Program .....	10
<b>6. Maintenance</b> .....	10
<b>7. Troubleshooting</b> .....	11
7.1 Wind Direction .....	11
7.2 Wind Speed .....	11
<b>8. References</b> .....	12

## **Figures**

3-1. Wind Monitor Mounted to a CSC Crossarm.....	4
--	---

## **Tables**

1-1. R.M. Young Wind Monitor Variations .....	1
1-2. Recommended Lead Lengths .....	1
4-1a. Connections to CSC Dataloggers (05103-10, 05305-10).....	5
4-1b. Connections to CSC Dataloggers (05106-10, 05106C-10).....	5
4-2. Connections to R.M. Young displays 05103, 05305, 05106, 05106C ...	6
5-1. Wind Speed Multiplier (with Configuration Code 21).....	7
5-2. Parameters for Wind Direction.....	7
5-3. Wiring for Example Programs .....	8

## ***Appendices***

- A. - Determining True North
- B - R.M. Young Wind Monitor Manuals
- C. - Cable and Wiring Diagrams
- D. - Exploded Views and Section Views
- E. - Calibration Accessories

# ***R.M. Young Wind Monitors***

## **1. General Description**

<b>Table 1-1. RM Young Wind Monitor Variations</b>	
<b>Model</b>	<b>Description</b>
<b>05103</b>	Standard Wind Monitor, RMY Configuration
<b>05103-10</b>	Standard Wind Monitor, CSC Configuration
<b>05106</b>	Marine Wind Monitor, RMY Configuration
<b>05106-10</b>	Marine Wind Monitor, CSC Configuration
<b>05106C</b>	Marine Wind Monitor, RMY Configuration, with Weatherproof Connectors
<b>05106C-10</b>	Marine Wind Monitor, CSC Configuration, with Weatherproof Connectors
<b>05305</b>	Air Quality Wind Monitor, RMY Configuration
<b>05305-10</b>	Air Quality Wind Monitor, CSC Configuration

The R.M. Young Wind Monitor sensors are used to measure horizontal wind speed and direction. There are several variations of the wind monitor, as presented in Table 1-1. Some models are configured for use with R.M. Young displays such as the Wind Tracker or Translator, others are configured for use with Campbell Scientific dataloggers.

Wind speed is measured with a helicoid-shaped, four-blade propeller. Rotation of the propeller produces an AC sine wave signal with frequency proportional to wind speed.

Vane position is transmitted by a 10K ohm potentiometer. With a precision excitation voltage applied, the output voltage is proportional to wind direction.

Lead length for the Wind Monitor is specified when the sensor is ordered. Table 1-1 gives the recommended lead length for mounting the sensor at the top of the tripod/tower with a crossarm.

<b>TABLE 1-2. Recommended Lead Lengths</b>							
<b>CM6</b>	<b>CM10</b>	<b>CM110</b>	<b>CM115</b>	<b>CM120</b>	<b>UT10</b>	<b>UT20</b>	<b>UT30</b>
10'	13'	13'	19'	24'	13'	24'	34'

The R.M. Young Instruction Manual for each model is also included as an appendix to this manual. Each manual includes operating principles, installation and alignment guide, and calibration information.

## 2. Specifications

	<i>05103 05103-10</i>	<i>05106 05106-10 05106C 05106C-10</i>	<i>05305 05305-10</i>
<b>Wind Speed</b>			
Range:	0-100 m/s (0-224 mph)	0-100 m/s (0-224 mph)	0-50 m/s (0-112 mph)
Accuracy:	±0.3 m/s (±0.6 mph)	±0.3 m/s (±0.6 mph)	±0.2 m/s (±0.4 mph)
Starting Threshold:	1.0 m/s (2.2 mph)	1.1 m/s (2.4 mph)	0.4 m/s (0.9 mph)
Distant Constant (63% Recovery):	2.7 m (8.9 ft)	2.7 m (8.9 ft)	2.1 m (6.9 ft)
Output:	A/C Voltage (3 pulses per revolution) 1800 RPM 90 Hz = 8.8 m/s (19.7 mph)	A/C Voltage (3 pulses per revolution) 1800 RPM 90 Hz = 8.8 m/s (19.7 mph)	A/C Voltage (3 pulses per revolution) 1800 RPM 90 Hz = 9.2 m/s (20.6 mph)
<b>Wind Direction</b>			
Range:	0-360° Mechanical, 0-355° Electrical (5° Open)	0-360° Mechanical, 0-355° Electrical (5° Open)	0-360° Mechanical, 0-355° Electrical (5° Open)
Accuracy:	±3°	±3°	±3°
Starting Threshold at 10° Displacement:	1.1 m/s (2.2 mph)	1.1 m/s (2.2 mph)	0.5 m/s (1.0 mph)
Delay Distance (50% Recovery):	1.3m (4.3 ft)	1.3m (4.3 ft)	1.2m (3.9 ft)
Damping Ratio:	0.25	0.25	0.45
Damped Natural Wavelength:	7.2m (23.6 ft)	7.2m (23.6 ft)	4.4m (14.4 ft)
Output:	Analog D/C Voltage from 10kohm Potentiometer	Analog D/C Voltage from 10kohm Potentiometer	Analog D/C Voltage from 10kohm Potentiometer
<b>Power</b>	Switched Excitation supplied by the Datalogger	Switched Excitation supplied by the Datalogger	Switched Excitation supplied by the Datalogger

	<b>05103 05103-10</b>	<b>05106 05106-10 05106C 05106C-10</b>	<b>05305 05305-10</b>
<b>Operating Temperature</b>	-50°C to 50°C, assuming non-riming conditions	-50°C to 50°C, assuming non-riming conditions	-50°C to 50°C, assuming non-riming conditions
<b>Dimensions</b>			
Overall:	37 cm H by 55 cm L (14.6 " H by 21.7 " L)	37 cm H by 55 cm L (14.6 " H by 21.7 " L)	38 cm H by 65 cm L (15.0 " H by 25.6 " L)
Main Housing Diameter:	5 cm (2.0 ")	5 cm (2.0 ")	5 cm (2.0 ")
Propeller Diameter:	18 cm (7.1 ")	18 cm (7.1 ")	20 cm (7.9 ")
Mounting Pipe:	34 mm (1.34 ") OD; Standard 1.0 " IPS Schedule 40	34 mm (1.34 ") OD; Standard 1.0 " IPS Schedule 40	34 mm (1.34 ") OD; Standard 1.0 " IPS Schedule 40
<b>Weight</b>			
Sensor:	1.5 kg (3.2 lbs)	1.5 kg (3.2 lbs)	1.1 kg (2.5 lbs)
Shipping (Approximate):	2.3 kg (5.5 lbs)	2.3 kg (5.5 lbs)	2.3 kg (5.5 lbs)
<b>Cable</b>	Supplied by CSC  Standard Length 3.3m (10 ft)  Custom Lengths Available	Supplied by RMY / CSC Standard Length 3.3m* (10 ft) Custom Lengths Available * 05106C Standard Length 1m (3.3 ft) + Custom Length (with Connectors)	Supplied by CSC Standard Length 3.3m (10 ft)  Custom Lengths Available

**NOTE**

The wind monitor is manufactured by R.M. Young (Traverse City, Michigan), and cabled by CSC. The black outer jacket of the cable is Santoprene® rubber. This compound was chosen for its resistance to temperature extremes, moisture, and UV degradation. However, this jacket will support combustion in air. It is rated as slow burning when tested according to U.L. 94 H.B. and will pass FMVSS302. Local fire codes may preclude its use inside buildings.

### 3. Installation

The Wind Monitor mounts to a standard 1" IPS schedule 40 pipe (1.34" O.D). An orientation ring is provided so that the instrument can be removed for maintenance, and reinstalled without loss of the wind direction reference.

A Campbell Scientific crossarm can be purchased to mount the Wind Monitor at a distance from the tower or tripod, so as to minimize the shadowing effect of the structure.

Install the Wind Monitor and orientation ring as follows:

Place the orientation ring followed by the Wind Monitor on the vertical mounting pipe; do not tighten the band clamps yet. Orient the junction box so that it faces South.

Using a compass, you can orient the sensor to True North or Magnetic North, depending on your requirements. For a discussion on determining True North and correcting magnetic declination see Appendix A.

Alignment of the sensor is most easily done with two people after the datalogger has been programmed to measure wind direction. Sighting down the centerline of instrument, point the nose cone to a reference point for North or True North. While holding this position, rotate the base of the sensor until the datalogger reads 0. Make sure that the indexing pin on the orientation ring is engaged with the notch in the sensor, and tighten both band clamps.

When removing the sensor for maintenance, leave the orientation ring in place to ensure proper orientation upon re-installation of the sensor.

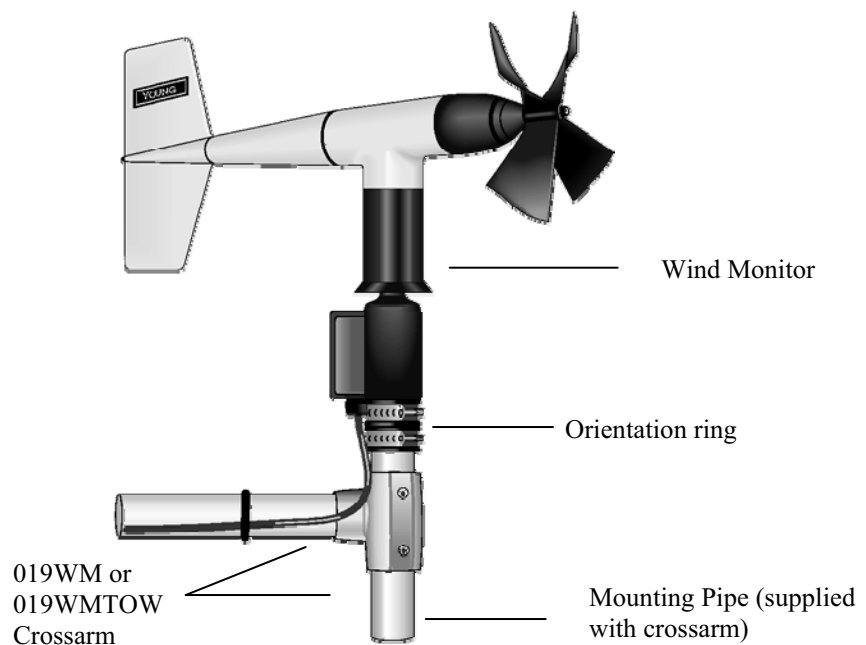

FIGURE 3.1 Wind Monitor Mounted to a CSC Crossarm



## 4. Wiring

Connections to Campbell Scientific dataloggers are given in Tables 4-1a and 4-1b. When Short Cut for Windows software is used to create the datalogger program, the sensor should be wired to the channels shown in the wiring diagram created by Short Cut. Colours may vary when using some versions of Short Cut.

Table 4-1a Connections to Campbell Scientific Dataloggers (05103-10, 05305-10)						
Board Connections	Colours	Description	CR800			
			CR9000(X)			
			CR5000	CR510	21X	
			CR3000	CR500	CR7	
			CR1000	CR10(X)	CR23X	CR200
WS SIG	Red	Wind Speed Signal	Pulse	Pulse	Pulse	P_LL
WS REF	Black	Wind Speed Reference	⏚	G	⏚	⏚
WD SIG	Green	Wind Direction Signal	SE Analog	SE Analog	SE Analog	SE Analog
WD EXC	Blue	Wind Direction Excitation	Excitation	Excitation	Excitation	Excitation
WD REF	White	Wind Direction Reference	⏚	AG	⏚	⏚
EARTH GND	Clear	Shield	⏚	G	⏚	⏚

Table 4-1b Connections to Campbell Scientific Dataloggers (05106-10, 05106C-10)							
05106-10 & 05106C-10 Board Connections	05106-10 & 05106C-10 Colours	05106C-10 Connector Pins	Description	CR800			
				CR9000(X)			
				CR5000	CR510	21X	
				CR3000	CR500	CR7	
				CR1000	CR10(X)	CR23X	CR200
F	Red	Pin E	Wind Speed Signal	Pulse	Pulse	Pulse	P_LL
E	Blue	Pin D	Wind Speed Reference	⏚	G	⏚	⏚
B	Green	Pin C	Wind Direction Signal	SE Analog	SE Analog	SE Analog	SE Analog
C	White	Pin B	Wind Direction Excitation	Excitation	Excitation	Excitation	Excitation
A	Black	Pin A	Wind Direction Reference	⏚	AG	⏚	⏚
D	Clear	Pin F	Shield	⏚	G	⏚	⏚

Connections to R.M. Young displays are give in Table 4-2.

<b>Table 4-2 Connections to RM Young Displays (05103, 05305, 05106, 05106C)</b>					
<b>Board Connections (05103 &amp; 05305 / 05106 &amp; 05106C)</b>	<b>Connection Description</b>	<b>Sensors</b>			
		<b>05103</b>	<b>05305</b>	<b>05106 &amp; 05106C</b>	<b>05106C Connector Pins</b>
WS SIG / F	Wind Speed Signal	Red	Red	Red	Pin E
WS REF / E	Wind Speed Reference	No Connection	No Connection	Blue	Pin D
WD SIG / B	Wind Direction Signal	Green	Green	Green	Pin C
WD EXC / C	Wind Direction Excitation	White	White	White	Pin B
WD REF / A	Wind Direction / Signal Reference	Black	Black	Black	Pin A
EARTH GND / D	Shield	Clear	Clear	Clear	Pin F

## 5. Example Programs – CSC Loggers

This section is for users who write their own programs. A datalogger program to measure this sensor can be created using Campbell Scientific’s Short Cut Program Builder software. You do not need to read this section to use Short Cut.

### 5.1 Wind Speed

Wind speed is measured with the pulse count instruction. With the pulse count instruction, specify the low level AC configuration code. For dataloggers programmed with Edlog, specify configuration code 21 to output frequency in Hertz.

The expression for wind speed (U) is:

$$U = MX + B$$

where

M = multiplier

X = number of pulses per second (Hertz)

B = offset

Table 5-1 lists the multipliers to obtain different units when the pulse count instruction is configured to output Hz (configuration code 21). The helicoid

propeller has a calibration that passes through zero, so the offset is zero (Gill, 1973; Baynton, 1976).

<b>Table 5-1 Wind Speed Multipliers (With Configuration Code 21*)</b>				
<b>Model</b>	<b>m/s</b>	<b>kmph</b>	<b>mph</b>	<b>knots</b>
05103-10	0.0980	0.3528	0.2192	0.1904
05106-10	0.0980	0.3528	0.2192	0.1904
05106C	0.0980	0.3528	0.2192	0.1904
05305-10	0.1024	0.3686	0.2290	0.1989
* If Configuration Code 11 is used, the multiplier above is divided by the execution interval in seconds.				

## 5.2 Wind Direction

The wind vane is coupled to a 10K potentiometer. The potentiometer has a 5 degree dead band between 355 and 360 degrees, therefore the maximum signal is 355 degrees. A 1 M ohm resistor between the signal and ground pulls the signal to 0 mV (0 degrees) when wind direction is in the dead band. The potentiometer is measured with a half bridge measurement instruction, which applies an excitation voltage and makes a Single-Ended voltage measurement. The multiplier converts the measurement result to degrees.

The EX-DEL-SE measurement instruction is used for dataloggers that are programmed with Edlog (e.g. CR10X, CR23X) and the CR200. The measurement result is mV; the multiplier to convert mV to degrees is 355deg/excitation mV.

The BRHalf measurement instruction is used for dataloggers that are programmed with CRBasic (e.g. CR1000, CR3000). The measurement result is the measured mV/excitation mV; the multiplier to convert mV/excitation mV to degrees is 355.

Some CR1000 measurement sequences cause the measurement of the wind direction to return a negative wind direction (-30°) while in the dead band. This can be overcome by using a delay of 40 ms (40,000µs) or by setting negative wind direction values to 0.0: If WindDir < 0, then WindDir = 0.0.

The excitation voltage, range codes, and multipliers for the different datalogger types are listed in Table 5-2.

<b>TABLE 5-2. Parameters for Wind Direction</b>				
	<b>CR10(X), CR510, CR200</b>	<b>CR7, 21X, CR23X</b>	<b>CR800 CR1000</b>	<b>CR5000, CR3000</b>
Measurement Range	2500 mV, slow	5000 mV, slow/60 Hz	2500 mV, 60 Hz, reverse excitation	5000 mV, 60 Hz, reverse excitation

Excitation Voltage	2500 mV	5000 mV	2500 mV	5000 mV
Multiplier	0.142 deg/mV	0.071 deg/mV	355 deg excitation (mV/mV)	355 deg excitation (mV/mV)
Offset	0	0	0	0

### 5.3 Wind Vector Processing Instruction (Output)

The Wind Vector output instruction is used to process and store mean wind speed, unit vector mean wind direction, and Standard Deviation of the wind direction (optional) using the measured wind speed and direction samples.

### 5.4 Example Programs

The following programs measure the Wind Monitor 05103-10 every 5 seconds, and store mean wind speed, unit vector mean direction, and standard deviation of the direction every 60 minutes. Wiring for the examples is given in Table 5-3.

Table 5-3 Wiring for Example Programs			
		CR10(X)	CR1000
Red	Wind Speed Signal	P1	P1
Black	Wind Speed Reference	G	⏏
Green	Wind Direction Signal	SE1	SE1
Blue	Wind Direction Excitation	EX1	EX1
White	Wind Direction Reference	AG	⏏
Clear	Shield	G	⏏

#### 5.4.1 CR10X Example Program

```

;{CR10X}
*Table 1 Program
  01: 5.0000      Execution Interval (seconds)

1: Pulse (P3)
  1: 1           Reps
  2: 1           Pulse Channel 1
  3: 21          Low Level AC, Output Hz
  4: 3           Loc [ WS_ms ]
  5: 0.098       Multiplier
  6: 0           Offset
    
```

```

2: Excite-Delay (SE) (P4)
  1: 1      Reps
  2: 5      2500 mV Slow Range ; 5000 mV(slow/60 hz) Range for CR23X, 21X, CR7
  3: 1      SE Channel
  4: 1      Excite all reps w/Exchan 1
  5: 2      Delay (0.01 sec units)
  6: 2500   mV Excitation ; 5000 mV for CR23X, 21X, CR7
  7: 4      Loc [ WindDir ]
  8: 0.142  Multiplier ; 0.071 for CR23X, 21X, CR7
  9: 0      Offset

3: If (X<=>F) (P89)
  1: 4      X Loc [ WindDir ]
  2: 3      >=
  3: 360    F
  4: 30     Then Do

4: Z=F x 10^n (P30)
  1: 0      F
  2: 0      n, Exponent of 10
  3: 4      Z Loc [ WindDir ]

5: End (P95)

6: If time is (P92)
  1: 0      Minutes (Seconds --) into a
  2: 60     Interval (same units as above)
  3: 10     Set Output Flag High (Flag 0)

7: Set Active Storage Area (P80)
  1: 1      Final Storage Area 1
  2: 101    Array ID

8: Real Time (P77)
  1: 1220   Year,Day,Hour/Minute (midnight = 2400)

9: Wind Vector (P69)
  1: 1      Reps
  2: 0      Samples per Sub-Interval
  3: 0      S, theta(1), sigma(theta(1)) with polar sensor
  4: 3      Wind Speed/East Loc [ WS_ms ]
  5: 4      Wind Direction/North Loc [ WindDir ]
    
```

## 5.4.2 CR1000 Example Program

```

'CR1000
'Declare Variables and Units
Public Batt_Volt
Public WS_ms
Public WindDir

Units Batt_Volt=Volts
Units WS_ms=meters/second
Units WindDir=Degrees

'Define Data Tables
DataTable(Table1,True,-1)
  DataInterval(0,60,Min,10)
  WindVector (1,WS_ms,WindDir,FP2,False,0,0,0)
  FieldNames("WS_ms_S_WVT,WindDir_D1_WVT,WindDir_SD1_WVT")
EndTable

'Main Program
BeginProg
  Scan(5,Sec,1,0)
  'Default Datalogger Battery Voltage measurement Batt_Volt:
  Battery(Batt_Volt)
  '05103-10 Wind Speed & Direction Sensor measurements WS_ms and WindDir:
  PulseCount(WS_ms,1,1,1,1,0.098,0)
  BrHalf(WindDir,1,mV2500,1,1,1,2500,True,0,_60Hz,355,0) ' mV5000
  '5000 mV excitation and mV 5000 range for CR3000 and CR5000 dataloggers,
  2500mV excitation and mV 2500 range for CR800 and CR1000 dataloggers

  'Over range correction calculation
  If WindDir>=360 Then WindDir=0
  If WindDir<0 Then WindDir=0
  'Call Data Tables and Store Data
  CallTable(Table1)
  NextScan
EndProg

```

## 6. Maintenance

R.M. Young suggests that the anemometer bearings and the potentiometer be inspected at least every 24 months. Only a qualified technician should perform the replacement.

Obtain an RMA number before returning the sensor to Campbell Scientific for service.

## 7. Troubleshooting (05103-10, 05106-10, 05106C-10, 05305-10)

### 7.1 Wind Direction

Symptom: -9999 or no change in direction

1. Check that the sensor is wired to the Excitation and Single-Ended channel specified by the measurement instruction.
2. Verify that the excitation voltage and Range code are correct for the datalogger type.
3. Disconnect the sensor from the datalogger and use an ohm meter to check the potentiometer. Resistance should be about 10K ohms between the Blue and White wires. The resistance between either the Blue/Green or White/Green wires should vary between about 1K to 11K depending on vane position. Resistance when the vane is in the 5 degree dead band should be about 1M ohm.

Symptom: Incorrect wind direction

1. Verify that the Excitation voltage, Range code, multiplier and offset parameters are correct for the datalogger type.
2. Check orientation of sensor as described in Section 3.

### 7.2 Wind Speed

Symptom: No wind speed

1. Check that the sensor is wired to the Pulse channel specified by the Pulse count instruction.
2. Disconnect the sensor from the datalogger and use an ohm meter to check the coil. The resistance between the red and black wires should be about 2075 ohms. Infinite resistance indicates an open coil; low resistance indicates a shorted coil.
3. Verify that the Configuration Code, and Multiplier and Offset parameters for the Pulse Count instruction are correct for the datalogger type.

Symptom: Wind speed does not change

1. For the dataloggers that are programmed with Edlog, the input location for wind speed is not updated if the datalogger is getting "Program Table Overruns". Increase the execution interval (scan rate) to prevent overruns.

## 8. References

Gill, G.C., 1973: The Helicoid Anemometer Atmosphere, II, 145-155.

Baynton, H.W., 1976: Errors in Wind Run Estimates from Rotational Anemometers Bul. Am. Met. Soc., vol. 57, No. 9, 1127-1130.



# **Appendix A. Wind Direction Sensor Orientation**

---

## **A.1 Determining True North and Sensor Orientation**

Orientation of the wind direction sensor is done after the datalogger has been programmed, and the location of True North has been determined. True North is usually found by reading a magnetic compass and applying the correction for magnetic declination; where magnetic declination is the number of degrees between True North and Magnetic North. Magnetic declination for a specific site can be obtained from a map, local airport, or through the Natural Resources Canada Web site at [www.gsc.nrcan.gc.ca/geomag/field/magdec\\_e.php](http://www.gsc.nrcan.gc.ca/geomag/field/magdec_e.php). A general map showing magnetic declination for Canada is shown in Figure A-1.

Declination angles east of True North are considered negative, and are subtracted from 0 degrees to get True North as shown Figure A-2. Declination angles west of True North are considered positive, and are added to 0 degrees to get True North as shown in Figure A-3.

Orientation is most easily done with two people, one to aim and adjust the sensor, while the other observes the wind direction displayed by the datalogger.

1. Establish a reference point on the horizon for True North.
2. Sighting down the instrument center line, aim the nose cone, or counterweight at True North. Display the input location for wind direction using the \*6 mode of the datalogger, or, the Monitor Mode of LoggerNet with an on-line PC.
3. Loosen the band clamps or set screws that secure the base of the sensor to the mast or crossarm. While holding the vane position, slowly rotate the sensor base until the datalogger indicates 0 degrees. Tighten the band clamps or set screws loosened previously.
4. Engage the orientation ring indexing pin in the notch at the instrument base (05103, 05106, and 05305 sensors only), and tighten the band clamp on the orientation ring.

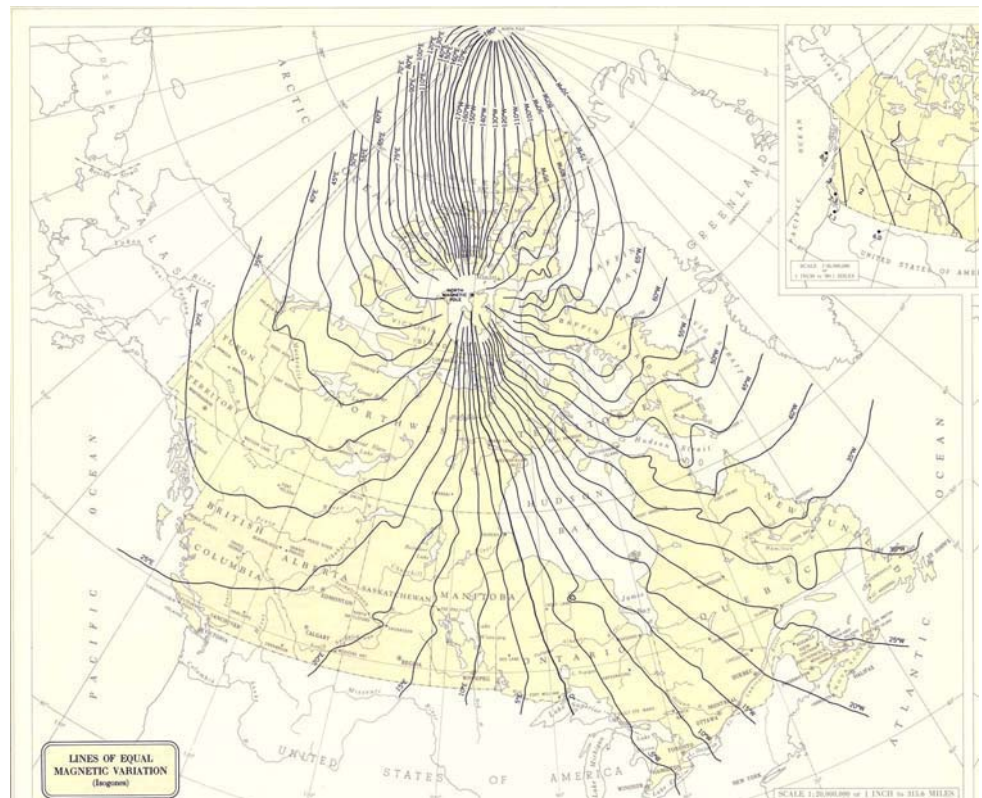

FIGURE A-1. Magnetic Declination for Canada

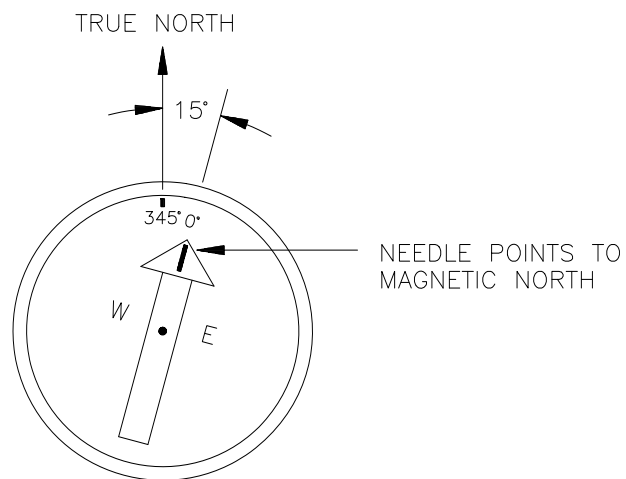
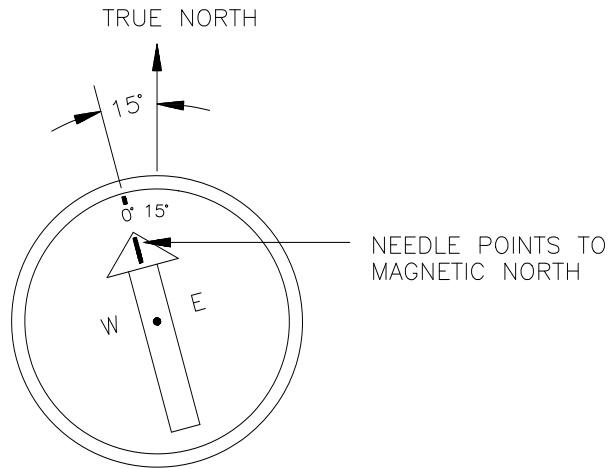

FIGURE A-2. Declination Angles East of True North Are Subtracted From 0 to Get True North



*FIGURE A-3. Declination Angles West of True North Are Added to 0 to Get True North*

## **Appendix B**

RM Young Wind Monitor Manuals



## MODEL 05106, 05106C WIND MONITOR-MA



### WIND SPEED SPECIFICATION SUMMARY:

Range	0 to 60 m/s (130 mph), gust survival 100 m/s (220 mph)
Sensor	18 cm diameter 4-blade helicoid propeller molded of polypropylene 29.4 cm air passage per revolution
Pitch Distance Constant	2.7 m (8.9 ft.) for 63% recovery
Threshold Sensitivity	1.1 m/s (2.4 mph)
Transducer	Centrally mounted stationary coil, 2K Ohm nominal DC resistance
Transducer Output	AC sine wave signal induced by rotating magnet on propeller shaft. 125 mV p-p at 100 rpm. 12.5 V p-p at 10,000 rpm.
Output Frequency	3 cycles per propeller revolution (0.098 m/s per Hz)

### WIND DIRECTION (AZIMUTH) SPECIFICATION SUMMARY:

Range	360° mechanical, 355° electrical (5° open)
Sensor	Balanced vane, 38 cm (15 in) turning radius.
Damping Ratio	0.25
Delay Distance	1.3 m (4.3 ft) for 50% recovery
Threshold Sensitivity	1.1 m/s (2.4 mph) at 10° displacement
Damped Natural Wavelength	7.4 m (24.3 ft)
Undamped Natural Wavelength	7.2 m (23.6 ft)
Transducer	Precision conductive plastic potentiometer, 10K ohm resistance ( $\pm 20\%$ ), 0.25% linearity, life expectancy 50 million revolutions, rated 1 watt at 40° C, 0 watts at 125° C
Transducer Excitation Requirement	Regulated DC voltage, 15 VDC max
Transducer Output	Analog DC voltage proportional to azimuth angle with regulated excitation voltage applied across potentiometer.

### GENERAL

Operating Temperature: -50 to 50°C (-58 to 122°F)

### INTRODUCTION

The Wind Monitor-MA-MA measures horizontal wind speed and direction. Originally developed for ocean data buoy use, it is rugged and corrosion resistant yet accurate and light weight. The main housing, nose cone, propeller, and other internal parts are injection molded U.V. stabilized plastic. Both the propeller and vertical shafts use stainless steel precision grade ball bearings. Bearings have light contacting teflon seals and are filled with a low torque wide temperature range grease to help exclude contamination and moisture.

Propeller rotation produces an AC sine wave signal with frequency proportional to wind speed. This AC signal is induced in a stationary coil by a six pole magnet mounted on the propeller shaft. Three complete sine wave cycles are produced for each propeller revolution.

Vane position is transmitted by a 10K ohm precision conductive plastic potentiometer which requires a regulated excitation voltage. With a constant voltage applied to the potentiometer, the output signal is an analog voltage directly proportional to azimuth angle.

The instrument mounts on standard one inch pipe, outside diameter 34 mm (1.34"). An orientation ring is provided so the instrument can be removed for maintenance and reinstalled without loss of wind direction reference. Both mounting post assembly and orientation ring are secured to the mounting pipe by stainless steel band clamps. A 1 meter (3.3 ft) pigtail cable assembly is supplied for electrical connections. For longer cable lengths a user supplied junction box or connector may be used. A variety of devices are available for signal conditioning, display, and recording of wind speed and direction.

### INITIAL CHECKOUT

When the Wind Monitor-MA is unpacked it should be checked carefully for any signs of shipping damage. Remove the plastic nut on the propeller shaft. Install the propeller on the shaft so the letter markings on the propeller face forward (into the wind). Engage the propeller into the molded ribs on the propeller shaft hub. The instrument is aligned, balanced and fully calibrated before shipment, however it should be checked both mechanically and electrically before installation. The vane and propeller should easily rotate 360° without friction. Check vane balance by holding the instrument base so the vane surface is horizontal. It should have near neutral torque without any particular tendency to rotate. A slight imbalance will not degrade performance.

The potentiometer requires a stable DC excitation voltage. Do not exceed 15 volts. When the potentiometer wiper is in the 5° deadband region, the output signal is "floating" and may show varying or unpredictable values. To prevent false readings, signal conditioning electronics should clamp the signal to excitation or reference level when this occurs. **NOTE: Young signal conditioning devices clamp the signal to excitation level.** Avoid a short circuit between the azimuth signal line and either the excitation or reference lines. Although there is a 1K ohm current limiting resistor in series with the wiper for protection, damage to the potentiometer may occur if a short circuit condition exists.

Before installation, connect the instrument to an indicator as shown in the wiring diagram and check for proper wind speed and azimuth values. Position the vane over a sheet of paper with 30° or 45° crossmarkings to check vane alignment. To check wind speed, temporarily remove the propeller and connect the shaft to an Anemometer Drive. Details appear in the CALIBRATION section of this manual.

- e) Tighten mounting post band clamp.
- f) Engage orientation ring indexing pin in notch at instrument base.
- g) Tighten orientation ring band clamp.

## INSTALLATION

Proper placement of the instrument is very important. Eddies from trees, buildings, or other structures can greatly influence wind speed and wind direction observations. To get meaningful data for most applications locate the instrument well above or upwind from obstructions. As a general rule, the air flow around a structure is disturbed to twice the height of the structure upwind, six times the height downwind, and up to twice the height of the structure above ground. For some applications it may not be practical or necessary to meet these requirements.

### FAILURE TO PROPERLY GROUND THE WIND MONITOR-MA MAY RESULT IN ERRONEOUS SIGNALS OR TRANSDUCER DAMAGE.

Grounding the Wind Monitor-MA is vitally important. Without proper grounding, static electrical charge can build up during certain atmospheric conditions and discharge through the transducers. This discharge can potentially cause erroneous signals or transducer failure. To direct the discharge away from the transducers, the mounting post assembly in which the transducers are mounted is made with a special antistatic plastic. The Wind Monitor-MA should be mounted on a metal pipe which is connected to earth ground. The mounting pipe should not be painted where the Wind Monitor-MA is mounted. Towers or masts set in concrete should be connected to one or more grounding rods.

If it is difficult to ground the mounting post in this manner, the following method should be used. The sensor cable shield wire is internally connected to the antistatic mounting post. This shield wire should be connected to an earth ground. (Refer to wiring diagram)

Initial installation is most easily done with two people; one to adjust the instrument position and the other to observe the indicating device. After initial installation, the instrument can be removed and returned to its mounting without realigning the vane since the orientation ring preserves the wind direction reference. Install the Wind Monitor-MA following these steps:

1. MOUNT WIND MONITOR-MA
  - a) Place orientation ring on mounting post. Do Not tighten band clamp yet.
  - b) Place Wind Monitor-MA on mounting post. Do Not tighten band clamp yet.
2. CONNECT SENSOR CABLE
  - a) Route cable carefully to avoid strain.
  - b) Use of a waterproof connector or junction box is recommended.
3. ALIGN VANE
  - a) Connect instrument to an indicator.
  - b) Choose a known wind direction reference point on the horizon.
  - c) Sighting down instrument centerline, point nose cone at reference point on horizon.
  - d) While holding vane in position, slowly turn base until indicator shows proper value.

## CALIBRATION

The Wind Monitor-MA is fully calibrated before shipment and should require no adjustments. Recalibration may be necessary after some maintenance operations. Periodic calibration checks are desirable and may be necessary where the instrument is used in programs which require auditing of sensor performance.

Accurate wind direction calibration requires a Model 18112 Vane Angle Bench Stand. Begin by connecting the instrument to a signal conditioning circuit which has some method of indicating azimuth value. This may be a display which shows azimuth values in angular degrees or simply a voltmeter monitoring the output. Orient the base with the junction box at 180°. Visually align the vane with the crossmarkings and observe the indicator output. If the vane position and indicator do not agree within 5°, adjust the potentiometer coupling inside the main housing. Details for making this adjustment appear in the MAINTENANCE, potentiometer replacement outline, step 7. It is important to note that while full scale azimuth on signal conditioning electronics may be 360°, full scale azimuth signal from the instrument is 355°. The signal conditioning electronics must be adjusted accordingly. For example, in a circuit where 0 to 1.000 VDC represents 0° to 360°, the output must be adjusted for 0.986 VDC when the instrument is at 355°. ( $355°/360° \times 1.000 \text{ volts} = 0.986 \text{ volts}$ )

Wind speed calibration is determined by propeller pitch and the output characteristics of the transducer. Calibration formulas showing wind speed vs. propeller rpm and output frequency are included below. Standard accuracy is  $\pm 0.3 \text{ m/s}$  (0.6mph). For greater accuracy, the device must be individually calibrated in comparison with a wind speed standard. Contact the factory or your supplier to schedule a NIST (National Institute of Standards & Technology) traceable wind tunnel calibration in our factory.

To calibrate wind system electronics using a signal from the instrument, temporarily remove the propeller and connect an Anemometer Drive to the propeller shaft. Apply the appropriate calibration formula to the calibrating motor rpm and adjust the electronics for the proper value. For example, with the propeller shaft turning at 3600 rpm adjust an indicator to display 17.6 meters per second ( $3600 \text{ rpm} \times 0.00490 \text{ m/s/rpm} = 17.6 \text{ m/s}$ ).

### CALIBRATION FORMULAS

#### Model 05106 Wind Monitor-MA w / 08234 Propeller

##### WIND SPEED vs PROPELLER RPM

m/s	=	0.00490 x rpm
knots	=	0.00952 x rpm
mph	=	0.01096 x rpm
km/h	=	0.01764 x rpm

##### WIND SPEED vs OUTPUT FREQUENCY

m/s	=	0.0980 x Hz
knots	=	0.1904 x Hz
mph	=	0.2192 x Hz
km/h	=	0.3528 x Hz

## **MAINTENANCE**

---

Given proper care, the Wind Monitor-MA should provide years of service. The only components likely to need replacement due to normal wear are the precision ball bearings and the wind direction potentiometer. Only a qualified instrument technician should perform the replacement. If service facilities are not available, return the instrument to the company. Refer to the drawings to become familiar with part names and locations. The asterisk\* which appears in the following outlines is a reminder that maximum torque on all set screws is 80 oz-in.

### **POTENTIOMETER REPLACEMENT:**

---

The potentiometer has a life expectancy of fifty million revolutions. As it becomes worn, the element may begin to produce noisy signals or become nonlinear. When signal noise or non-linearity becomes unacceptable, replace the potentiometer. Refer to exploded view drawing and proceed as follows:

1. REMOVE MAIN HOUSING
  - a) Unscrew nose cone from main housing. Set o-ring aside for later use.
  - b) Remove 4 screws attaching housing.
  - c) Gently push main housing latch.
  - d) While pushing latch, lift main housing up and remove it from vertical shaft bearing rotor.
2. UNSOLDER TRANSDUCER WIRES
  - a) Remove screws securing cable and strain relief assembly to mounting post.
  - b) Slowly pull strain relief away from mounting post exposing circuit board with transducer wire connections.
3. REMOVE POTENTIOMETER
  - a) Loosen set screw on potentiometer coupling and remove it from potentiometer adjust thumbwheel.
  - b) Loosen set screw on potentiometer adjust thumbwheel and remove it from potentiometer shaft extension.
  - c) Loosen two set screws at base of transducer assembly and remove assembly from vertical shaft.
  - d) Unscrew potentiometer housing from potentiometer mounting & coil assembly.
  - e) Push potentiometer out of potentiometer mounting & coil assembly by applying firm but gentle pressure on potentiometer shaft extension. Set o-ring aside for later use.
  - f) Loosen set screw on potentiometer shaft extension and remove it from potentiometer shaft.
4. INSTALL NEW POTENTIOMETER
  - a) Place potentiometer shaft extension with o-ring on new potentiometer (Gap 0.040") and tighten set screw\*. Regrease o-ring if necessary.
  - b) Push new potentiometer into potentiometer mounting & coil assembly.
  - c) Feed potentiometer and coil wires through hole in bottom of potentiometer housing.
  - d) Screw potentiometer housing onto potentiometer mounting & coil assembly.
  - e) Gently pull transducer wires through bottom of potentiometer housing to take up any slack. Apply a small amount of silicone sealant around hole.
  - f) Install transducer assembly on vertical shaft allowing 0.5 mm (0.020") clearance from vertical bearing. Tighten set screws\* at bottom of transducer assembly.
  - g) Place potentiometer adjust thumbwheel on potentiometer shaft extension and tighten set screw\*.
  - h) Place potentiometer coupling on potentiometer adjust thumbwheel. Do Not tighten set screw yet.

### 5. RECONNECT TRANSDUCER WIRES

- a) Using needle-nose pliers or a paper clip bent to form a small hook, gently pull transducer wires through hole in mounting post.
- b) Solder wires to cable assembly. Apply small amount of silicone sealant to solder connections. Observe color code.
- c) Secure cable & strain relief assembly removed in step 2A.

### 6. REPLACE MAIN HOUSING

- a) Place main housing over vertical shaft bearing rotor. Be careful to align indexing key and channel in these two assemblies.
- b) Place main housing over vertical shaft bearing rotor until potentiometer coupling is near top of main housing.
- c) Turn potentiometer adjust thumbwheel until potentiometer coupling is oriented to engage ridge in top of main housing. Set screw on potentiometer coupling should be facing the front opening.
- d) With potentiometer coupling properly oriented, continue pushing main housing onto vertical shaft bearing rotor until main housing latch locks into position with a "click".
- e) Replace 4 screws.

### 7. ALIGN VANE

- a) Connect excitation voltage and signal conditioning electronics to terminal strip according to wiring diagram.
- b) With mounting post held in position so junction box is facing due south, orient vane to a known angular reference. Details appear in CALIBRATION section.
- c) Reach in through front of main housing and turn potentiometer adjust thumbwheel until signal conditioning system indicates proper value.
- d) Tighten set screw\* on potentiometer coupling.

### 8. REPLACE NOSE CONE

- a) Screw nose cone into main housing until o-ring seal is seated. Be certain threads are properly engaged to avoid cross-threading.

### **FLANGE BEARING REPLACEMENT:**

---

If anemometer bearings become noisy or wind speed threshold increases above an acceptable level, bearings may need replacement. Check anemometer bearing condition using a Model 18310 Propeller Torque Disc. Without it, a rough check can be performed by adding an ordinary paper clip (0.5 gm) to the tip of a propeller blade. Turn the blade with the paper clip to the "three o'clock" or "nine o'clock" position and gently release it. Failure to rotate due to the weight of the paper clip indicates anemometer bearings need replacement. Repeat this test at different positions to check full bearing rotation. If needed, bearings are replaced as follows.

#### 1. REMOVE OLD BEARINGS

- a) Unscrew nose cone. Do not lose o-ring seal.
- b) Loosen set screw on magnet shaft collar and remove magnet.
- c) Slide propeller shaft out of nose cone assembly.
- d) Remove front bearing cap which covers front bearing.
- e) Remove both front and rear bearings from nose cone assembly. Insert edge of a pocket knife under bearing flange and lift it out.

#### 2. INSTALL NEW BEARINGS

- a) Insert new front and rear bearings into nose cone.
- b) Replace front bearing cap.
- c) Carefully slide propeller shaft through bearings.
- d) Place magnet on propeller shaft allowing 0.5 mm (0.020") clearance from rear bearing.

\*Max set screw torque 80 oz-in

- e) Tighten set screw\* on magnet shaft collar.
- f) Screw nose cone into main housing until o-ring seal is seated. Be certain threads are properly engaged to avoid cross-threading.

**VERTICAL SHAFT BEARING REPLACEMENT:**

Vertical shaft bearings are much larger than the anemometer bearings. Ordinarily, these bearings will require replacement less frequently than anemometer bearings. Check bearing condition using a Model 18331 Vane Torque Gauge. Without it, a rough check can be performed by holding the instrument with the vane horizontal and placing a 3 gm weight near the aft edge of the fin. A U.S. penny weighs about 3 gm and is convenient for this check. Failure to rotate downward indicates the vertical bearings need replacement. Repeat this test at different positions to check full bearing rotation.

Since this procedure is similar to POTENTIOMETER REPLACEMENT, only the major steps are listed here.

1. REMOVE MAIN HOUSING
2. UNSOLDER TRANSDUCER WIRES AND REMOVE TRANSDUCER ASSEMBLY  
Loosen set screws at base of transducer assembly and remove entire assembly from vertical shaft.
3. REMOVE VERTICAL SHAFT BEARING ROTOR by sliding it upward off vertical shaft.
4. REMOVE OLD VERTICAL BEARINGS AND INSTALL NEW BEARINGS. When inserting new bearings, be careful not to apply pressure to bearing shields.
5. REPLACE VERTICAL SHAFT BEARING ROTOR.
6. REPLACE TRANSDUCER & RECONNECT WIRES
7. REPLACE MAIN HOUSING
8. ALIGN VANE
9. REPLACE NOSE CONE

**WARRANTY**

This product is warranted to be free of defects in materials and construction for a period of 12 months from date of initial purchase. Liability is limited to repair or replacement of defective item. A copy of the warranty policy may be obtained from R. M. Young Company.

**CE COMPLIANCE**

This product has been tested and shown to comply with European CE requirements for the EMC Directive. Please note that shielded cable must be used.

**Declaration of Conformity**

**Application of Council Directives:**  
89/336/EEC

**Standards to which Conformity is Declared:**  
EN 50082-1 (IEC 801-2, 3, 4)

**Manufacturer's Name and Address:**  
R. M. Young Company  
Traverse City, MI, 49686, USA

**Importer's Name and Address:**  
See Shipper or Invoice

**Type of Equipment:**  
Meteorological Instruments

**Model Number / Year of Manufacture:**  
05106/1996

I, the undersigned, hereby declare that the equipment specified conforms to the above Directives and Standards.

**Date / Place:**  
Traverse City, Michigan, USA February 19, 1996



David Poinsett  
R & D Manager, R. M. Young Company





# MODEL 05103 WIND MONITOR



## GENERAL

Operating Temperature: -50 to 50°C (-58 to 122°F)

## INTRODUCTION

The Wind Monitor measures horizontal wind speed and direction. Originally developed for ocean data buoy use, it is rugged and corrosion resistant yet accurate and light weight. The main housing, nose cone, propeller, and other internal parts are injection molded U.V. stabilized plastic. Both the propeller and vertical shafts use stainless steel precision grade ball bearings. Bearings have light contacting teflon seals and are filled with a wide temperature range grease to help exclude contamination and moisture.

Propeller rotation produces an AC sine wave signal with frequency proportional to wind speed. This AC signal is induced in a stationary coil by a six pole magnet mounted on the propeller shaft. Three complete sine wave cycles are produced for each propeller revolution.

Vane position is transmitted by a 10K ohm precision conductive plastic potentiometer which requires a regulated excitation voltage. With a constant voltage applied to the potentiometer, the output signal is an analog voltage directly proportional to wind direction angle.

### WIND SPEED SPECIFICATION SUMMARY

Range	0 to 60 m/s (130 mph), gust survival 100 m/s (220 mph)
Sensor	18 cm diameter 4-blade helicoid propeller molded of polypropylene
Pitch	29.4 cm air passage per revolution
Distance Constant	2.7 m (8.9 ft.) for 63% recovery
Threshold Sensitivity	1.0 m/s (2.2 mph)
Transducer	Centrally mounted stationary coil, 2K Ohm nominal DC resistance
Transducer Output	AC sine wave signal induced by rotating magnet on propeller shaft. 80 mV p-p at 100 rpm. 8.0 V p-p at 10,000 rpm.
Output Frequency	3 cycles per propeller revolution (0.0980 m/s per Hz)

The instrument mounts on standard one inch pipe, outside diameter 34 mm (1.34"). An orientation ring is provided so the instrument can be removed for maintenance and reinstalled without loss of wind direction reference. Both the mounting post assembly and the orientation ring are secured to the mounting pipe by stainless steel band clamps. Electrical connections are made in a junction box at the base. A variety of devices are available for signal conditioning, display, and recording of wind speed and direction.

### WIND DIRECTION (AZIMUTH) SPECIFICATION SUMMARY

Range	360° mechanical, 355° electrical (5° open)
Sensor	Balanced vane, 38 cm (15 in) turning radius.
Damping Ratio	0.3
Delay Distance	1.3 m (4.3 ft) for 50% recovery
Threshold Sensitivity	1.1 m/s (2.5 mph) at 10° displacement
Damped Natural Wavelength	7.4 m (24.3 ft)
Undamped Natural Wavelength	7.2 m (23.6 ft)
Transducer	Precision conductive plastic potentiometer, 10K ohm resistance (±20%), 0.25% linearity, life expectancy 50 million revolutions, rated 1 watt at 40° C, 0 watts at 125° C
Transducer Excitation Requirement	Regulated DC voltage, 15 VDC max
Transducer Output	Analog DC voltage proportional to azimuth angle with regulated excitation voltage applied across potentiometer.

## INITIAL CHECKOUT

When the Wind Monitor is unpacked it should be checked carefully for any signs of shipping damage.

Remove the plastic nut on the propeller shaft. Install the propeller on the shaft so the serial number on the propeller faces forward (into the wind). Engage the propeller into the molded ribs on the propeller shaft hub. The instrument is aligned, balanced and fully calibrated before shipment, however, it should be checked both mechanically and electrically before installation. The vane and propeller should easily rotate 360° without friction. Check vane balance by holding the instrument base so the vane surface is horizontal. It should have near neutral torque without any particular tendency to rotate. A slight imbalance will not degrade performance.

The potentiometer requires a stable DC excitation voltage. Do not exceed 15 volts. When the potentiometer wiper is in the 5° deadband region, the output signal is "floating" and may show varying or unpredictable values. To prevent false readings, signal conditioning electronics should clamp the signal to excitation or reference level when this occurs. **NOTE: Young signal conditioning devices clamp the signal to excitation level.** Avoid a short circuit between the wind direction signal line and either the excitation or reference lines. Although there is a 1K ohm current limiting resistor in series with the wiper for protection, damage to the potentiometer may occur if a short circuit condition exists.

Before installation, connect the instrument to an indicator as shown in the wiring diagram and check for proper wind speed and wind direction values. To check wind speed, temporarily remove the propeller and connect the shaft to an Anemometer Drive. Details appear in the CALIBRATION section of this manual.

## INSTALLATION

Proper placement of the instrument is very important. Eddies from trees, buildings, or other structures can greatly influence wind speed and wind direction observations. To get meaningful data for most applications locate the instrument well above or upwind from obstructions. As a general rule, the air flow around a structure is disturbed to twice the height of the structure upwind, six times the height downwind, and up to twice the height of the structure above ground. For some applications it may not be practical or necessary to meet these requirements.

### FAILURE TO PROPERLY GROUND THE WIND MONITOR MAY RESULT IN ERRONEOUS SIGNALS OR TRANSDUCER DAMAGE.

Grounding the Wind Monitor is vitally important. Without proper grounding, static electrical charge can build up during certain atmospheric conditions and discharge through the transducers. This discharge can cause erroneous signals or transducer failure. To direct the discharge away from the transducers, the mounting post assembly is made with a special antistatic plastic. It is very important that the mounting post be connected to a good earth ground. There are two ways this may be accomplished. First, the Wind Monitor may be mounted on a metal pipe which is connected to earth ground. The mounting pipe should not be painted where the Wind Monitor is mounted. Towers or masts set in concrete should be connected to one or more grounding rods. If it is difficult to ground the mounting post in this manner, the following method should be used. Inside the junction box the terminal labeled EARTH GND is internally connected to the antistatic mounting post. This terminal should be connected to an earth ground (Refer to wiring diagram).

Initial installation is most easily done with two people; one to adjust the instrument position and the other to observe the indicating device. After initial installation, the instrument can be removed and returned to its mounting without realigning the vane since the orientation ring preserves the wind direction reference. Install the Wind Monitor following these steps:

1. MOUNT WIND MONITOR
  - a) Place orientation ring on mounting post. Do Not tighten band clamp yet.
  - b) Place Wind Monitor on mounting post. Do Not tighten band clamp yet.
2. CONNECT SENSOR CABLE
  - a) Refer to wiring diagram located at back of manual.
3. ALIGN VANE
  - a) Connect instrument to an indicator.
  - b) Choose a known wind direction reference point on the horizon.
  - c) Sighting down instrument centerline, point nose cone at reference point on horizon.
  - d) While holding vane in position, slowly turn base until indicator shows proper value.
  - e) Tighten mounting post band clamp.
  - f) Engage orientation ring indexing pin in notch at instrument base.
  - g) Tighten orientation ring band clamp.

## CALIBRATION

The Wind Monitor is fully calibrated before shipment and should require no adjustments. Recalibration may be necessary after some maintenance operations. Periodic calibration checks are desirable and may be necessary where the instrument is used in programs which require auditing of sensor performance.

Accurate wind direction calibration requires a Model 18112 Vane Angle Bench Stand. Begin by connecting the instrument to a signal conditioning circuit which has some method of indicating wind direction value. This may be a display which shows wind direction values in angular degrees or simply a voltmeter monitoring the output. Orient the base so the junction box faces due south. Visually align the vane with the crossmarkings and observe the indicator output. If the vane position and indicator do not agree within 5°, adjust the potentiometer coupling inside the main housing. Details for making this adjustment appear in the MAINTENANCE, POTENTIOMETER REPLACEMENT, outline, step 7.

It is important to note that, while the sensor mechanically rotates through 360°, the full scale wind direction signal from the signal conditioning occurs at 355°. The signal conditioning electronics must be adjusted accordingly. For example, in a circuit where 0 to 1.000 VDC represents 0° to 360°, the output must be adjusted for 0.986 VDC when the instrument is at 355°. ( $355^\circ/360^\circ \times 1.000 \text{ volts} = 0.986 \text{ volts}$ )

Wind speed calibration is determined by propeller pitch and the output characteristics of the transducer. Calibration formulas showing wind speed vs. propeller rpm and output frequency are included below. Standard accuracy is  $\pm 0.3 \text{ m/s}$  (0.6mph). For greater accuracy, the sensor must be individually calibrated in comparison with a wind speed standard. Contact the factory or your supplier to schedule a NIST (National Institute of Standards & Technology) traceable wind tunnel calibration in our facility.

To calibrate wind system electronics using a signal from the instrument, temporarily remove the propeller and connect an Anemometer Drive to the propeller shaft. Apply the appropriate calibration formula to the calibrating motor rpm and adjust the electronics for the proper value. For example, with the propeller shaft turning at 3600 rpm adjust an indicator to display 17.6 meters per second [ $3600 \text{ rpm} \times 0.00490 \text{ (m/s)/rpm} = 17.6 \text{ m/s}$ ]

Details on checking bearing torque, which affects wind speed and direction threshold, appear in the following section.

## CALIBRATION FORMULAS

### Model 05103 Wind Monitor w / 08234 Propeller

#### WIND SPEED vs PROPELLER RPM

m/s	=	0.00490 x rpm
knots	=	0.00952 x rpm
mph	=	0.01096 x rpm
km/h	=	0.01764 x rpm

#### WIND SPEED vs OUTPUT FREQUENCY

m/s	=	0.0980 x Hz
knots	=	0.1904 x Hz
mph	=	0.2192 x Hz
km/h	=	0.3528 x Hz

## **MAINTENANCE**

---

Given proper care, the Wind Monitor should provide years of service. The only components likely to need replacement due to normal wear are the precision ball bearings and the wind direction potentiometer. Only a qualified instrument technician should perform the replacement. If service facilities are not available, return the instrument to the company. Refer to the drawings to become familiar with part names and locations. The asterisk \* which appears in the following outlines is a reminder that maximum torque on all set screws is 80 oz-in.

### **POTENTIOMETER REPLACEMENT**

---

The potentiometer has a life expectancy of fifty million revolutions. As it becomes worn, the element may begin to produce noisy signals or become nonlinear. When signal noise or non-linearity becomes unacceptable, replace the potentiometer. Refer to exploded view drawing and proceed as follows:

#### **1. REMOVE MAIN HOUSING**

- a) Unscrew nose cone from main housing. Set o-ring aside for later use.
- b) Gently push main housing latch.
- c) While pushing latch, lift main housing up and remove it from vertical shaft bearing rotor.

#### **2. UNSOLDER TRANSDUCER WIRE**

- a) Remove junction box cover, exposing circuit board.
- b) Remove screws holding circuit board.
- c) Unsolder three potentiometer wires (white, green, black), two wind speed coil wires (red, black) and earth ground wire (red) from board.

#### **3. REMOVE POTENTIOMETER**

- a) Loosen set screw on potentiometer coupling and remove it from potentiometer adjust thumbwheel.
- b) Loosen set screw on potentiometer adjust thumbwheel and remove it from potentiometer shaft extension.
- c) Loosen two set screws at base of transducer assembly and remove assembly from vertical shaft.
- d) Unscrew potentiometer housing from potentiometer mounting & coil assembly.
- e) Push potentiometer out of potentiometer mounting & coil assembly by applying firm but gentle pressure on potentiometer shaft extension. Set o-ring aside for later use.
- f) Loosen set screw on potentiometer shaft extension and remove it from potentiometer shaft.

#### **4. INSTALL NEW POTENTIOMETER**

- a) Place potentiometer shaft extension with o-ring on new potentiometer (Gap 0.040") and tighten set screw\*. Regrease o-ring if necessary.
- b) Push new potentiometer into potentiometer mounting & coil assembly.
- c) Feed potentiometer and coil wires through hole in bottom of potentiometer housing.
- d) Screw potentiometer housing onto potentiometer mounting & coil assembly.
- e) Gently pull transducer wires through bottom of potentiometer housing to take up any slack. Apply a small amount of silicone sealant around hole.
- f) Install transducer assembly on vertical shaft allowing 0.5 mm (0.020") clearance from vertical bearing. Tighten set screws\* at bottom of transducer assembly.
- g) Place potentiometer adjust thumbwheel on potentiometer shaft extension and tighten set screw\*.

- h) Place potentiometer coupling on potentiometer adjust thumbwheel. Do Not tighten set screw yet.

#### **5. RECONNECT TRANSDUCER WIRES**

- a) Using needle-nose pliers or a paper clip bent to form a small hook, gently pull transducer wires through hole in junction box.
- b) Solder wires to circuit board according to wiring diagram. Observe color code.
- c) Secure circuit board in junction box using two screws removed in step 2b. Do not overtighten.

#### **6. REPLACE MAIN HOUSING**

- a) Place main housing over vertical shaft bearing rotor. Be careful to align indexing key and channel in these two assemblies.
- b) Place main housing over vertical shaft bearing rotor until potentiometer coupling is near top of main housing.
- c) Turn potentiometer adjust thumbwheel until potentiometer coupling is oriented to engage ridge in top of main housing. Set screw on potentiometer coupling should be facing the front opening.
- d) With potentiometer coupling properly oriented, continue pushing main housing onto vertical shaft bearing rotor until main housing latch locks into position with a "click".

#### **7. ALIGN VANE**

- a) Connect excitation voltage and signal conditioning electronics to terminal strip according to wiring diagram.
- b) With mounting post held in position so junction box is facing due south, orient vane to a known angular reference. Details appear in CALIBRATION section.
- c) Reach in through front of main housing and turn potentiometer adjust thumbwheel until signal conditioning system indicates proper value.
- d) Tighten set screw\* on potentiometer coupling.

#### **8. REPLACE NOSE CONE**

- a) Screw nose cone into main housing until o-ring seal is seated. Be certain threads are properly engaged to avoid cross-threading.

### **FLANGE BEARING REPLACEMENT**

---

If anemometer bearings become noisy or wind speed threshold increases above an acceptable level, bearings may need replacement. Check anemometer bearing condition using a Model 18310 Propeller Torque Disc. If needed, bearings are replaced as follows.

#### **1. REMOVE OLD BEARINGS**

- a) Unscrew nose cone. Set o-ring aside for later use.
- b) Loosen set screw on magnet shaft collar and remove magnet.
- c) Slide propeller shaft out of nose cone assembly.
- d) Remove front bearing cap which covers front bearing.
- e) Remove both front and rear bearings from nose cone assembly. Insert edge of a pocket knife under bearing flange and lift it out.

#### **2. INSTALL NEW BEARINGS**

- a) Insert new front and rear bearings into nose cone.
- b) Replace front bearing cap.
- c) Carefully slide propeller shaft thru bearings.
- d) Place magnet on propeller shaft allowing 0.5 mm (0.020") clearance from rear bearing.
- e) Tighten set screw\* on magnet shaft collar.
- f) Screw nose cone into main housing until o-ring seal is seated. Be certain threads are properly engaged to avoid cross-threading.

\*Max set screw torque 80 oz-in

## **VERTICAL SHAFT BEARING REPLACEMENT**

---

Vertical shaft bearings are much larger than the anemometer bearings. Ordinarily, these bearings require replacement less frequently than anemometer bearings. Check bearing condition using a Model 18331 Vane Torque Gauge.

Since this procedure is similar to POTENTIOMETER REPLACEMENT, only the major steps are listed here.

1. REMOVE MAIN HOUSING
2. UNSOLDER TRANSDUCER WIRES AND REMOVE TRANSDUCER ASSEMBLY  
Loosen set screws at base of transducer assembly and remove entire assembly from vertical shaft.
3. REMOVE VERTICAL SHAFT BEARING ROTOR by sliding it upward off vertical shaft.
4. REMOVE OLD VERTICAL BEARINGS AND INSTALL NEW BEARINGS. When inserting new bearings, be careful not to apply pressure to bearing shields.
5. REPLACE VERTICAL SHAFT BEARING ROTOR.
6. REPLACE TRANSDUCER & RECONNECT WIRES
7. REPLACE MAIN HOUSING
8. ALIGN VANE
9. REPLACE NOSE CONE

## **WARRANTY**

---

This product is warranted to be free of defects in materials and construction for a period of 12 months from date of initial purchase. Liability is limited to repair or replacement of defective item. A copy of the warranty policy may be obtained from R. M. Young Company.

## **CE COMPLIANCE**

---

This product has been tested and shown to comply with European CE requirements for the EMC Directive (see Declaration of Conformity below). Please note that shielded cable must be used.

### **Declaration of Conformity**

**Application of Council Directives:**  
89/336/EEC

**Standards to which Conformity is Declared:**  
EN 50082-1(IEC 801-2,3,4)

**Manufacturer's Name and Address:**  
R. M. Young Company  
Traverse City, MI, 49686, USA

**Importer's Name and Address:**  
See Shipper or Invoice

**Type of Equipment:**  
Meteorological Instruments

**Model Number / Year of Manufacture:**  
05103/1996

I, the undersigned, hereby declare that the equipment specified conforms to the above Directives and Standards.

**Place / Date:**  
Traverse City, Michigan, USA / February 19, 1996



David Poinsett  
R & D Manager, R. M. Young Company



## MODEL 05305 WIND MONITOR - AQ



### WIND SPEED SPECIFICATION SUMMARY

Range	0 to 40 m/s (90 mph), gust survival 50 m/s (112 mph)
Sensor	20 cm diameter 4-blade helicoid propeller carbon fiber thermoplastic
Distance Constant	2.1 m (6.9 ft.) for 63% recovery
Threshold Sensitivity	0.4 m/s (0.9 mph)
Transducer	Centrally mounted stationary coil, 2K ohm nominal DC resistance
Transducer Output	AC sine wave signal induced by rotating magnet on propeller shaft. 80 mV p-p at 100 rpm. 8.0 V p-p at 10,000 rpm.
Output Frequency	3 cycles per propeller revolution (0.102 m/s per Hz)

### WIND DIRECTION (AZIMUTH) SPECIFICATION SUMMARY

Range	360° mechanical, 355° electrical (5° open)
Sensor	Balanced vane, 48.3 cm (19 in) turning radius.
Damping Ratio	0.45
Delay Distance	1.2 m (3.9 ft) for 50% recovery
Threshold Sensitivity	0.5 m/s (1.0 mph) at 10° displacement 0.7 m/s (1.6 mph) at 5° displacement
Damped Natural Wavelength	4.9 m (16.1 ft)
Undamped Natural Wavelength	4.4 m (14.4 ft)
Transducer	Precision conductive plastic potentiometer, 10K ohm resistance ( $\pm 20\%$ ), 0.25% linearity, life expectancy 50 million revolutions, rated 1 watt at 40°C, 0 watts at 125°C
Transducer Excitation Requirement	Regulated DC voltage, 15 VDC max
Transducer Output	Analog DC voltage proportional to azimuth angle with regulated excitation voltage applied across potentiometer.

### GENERAL

Operating temperature: -50 to 50°C (-58 to 122°F)

### INTRODUCTION

The Wind Monitor measures horizontal wind speed and direction. Developed for air quality applications, it is accurate, sensitive, and corrosion resistant. The main housing, nose cone, propeller, and other internal parts are injection molded U.V. stabilized plastic. The tail section is lightweight expanded polystyrene. Both the propeller and vertical shafts use stainless steel precision grade ball bearings. Bearings have shields to help exclude contamination and moisture.

Propeller rotation produces an AC sine wave signal with frequency proportional to wind speed. This AC signal is induced in a stationary coil by a six pole magnet mounted on the propeller shaft. Three complete sine wave cycles are produced for each propeller revolution.

Vane position is transmitted by a 10K ohm precision conductive plastic potentiometer which requires a regulated excitation voltage. With a constant voltage applied to the potentiometer, the output signal is an analog voltage directly proportional to azimuth angle.

The instrument mounts on standard one inch pipe, outside diameter 34 mm (1.34"). An orientation ring is provided so the instrument can be removed for maintenance and reinstalled without loss of wind direction reference. Both mounting post assembly and orientation ring are secured to the mounting pipe by stainless steel band clamps. Electrical connections are made in a junction box at the base. A variety of devices are available for signal conditioning, display, and recording of wind speed and direction.

### INITIAL CHECKOUT

When the Wind Monitor is unpacked it should be checked carefully for any signs of shipping damage.

Remove the plastic nut on the propeller shaft. Install the propeller on the shaft with the serial number of the propeller facing forward (into the wind). The instrument is aligned, balanced and fully calibrated before shipment; however, it should be checked both mechanically and electrically before installation. The vane and propeller should easily rotate 360° without friction. Check vane balance by holding the instrument base so the vane surface is horizontal. It should have near neutral torque without any particular tendency to rotate. A slight imbalance will not degrade performance.

The potentiometer requires a stable DC excitation voltage. Do not exceed 15 volts. When the potentiometer wiper is in the 5° deadband region, the output signal is "floating" and may show varying or unpredictable values. To prevent false readings, signal conditioning electronics should clamp the signal to excitation or reference level when this occurs. **NOTE: Young signal conditioning devices clamp the signal to excitation level.** Avoid a short circuit between the azimuth signal line and either the excitation or reference lines. Although there is a 1K ohm current limiting resistor in series with the wiper for protection, damage to the potentiometer may occur if a short circuit condition exists.

Before installation, connect the instrument to an indicator as shown in the wiring diagram and check for proper wind speed and azimuth values. To check wind speed, temporarily remove the propeller and connect the shaft to an Anemometer Drive. Details appear in the CALIBRATION section of this manual.

## INSTALLATION

Proper placement of the instrument is very important. Eddies from trees, buildings, or other structures can greatly influence wind speed and wind direction observations. To get meaningful data for most applications, locate the instrument well above or upwind from obstructions. As a general rule, the air flow around a structure is disturbed to twice the height of the structure upwind, six times the height downwind, and up to twice the height of the structure above ground. For some applications it may not be practical or necessary to meet these requirements.

### FAILURE TO PROPERLY GROUND THE WIND MONITOR MAY RESULT IN ERRONEOUS SIGNALS OR TRANSDUCER DAMAGE.

Grounding the Wind Monitor is vitally important. Without proper grounding static electrical charge can build up during certain atmospheric conditions and discharge through the transducers. This discharge can potentially cause erroneous signals or transducer failure. To direct the discharge away from the transducers, the mounting post assembly in which the transducers are mounted is made with a special antistatic plastic. Therefore it is very important that the mounting post be connected to a good earth ground. There are two ways this may be accomplished. First, the Wind Monitor may be mounted on a metal pipe which is connected to earth ground. The mounting pipe should not be painted where the Wind Monitor is mounted. Towers or masts set in concrete should be connected to one or more grounding rods. If it is difficult to ground the mounting post in this manner an alternative method should be used. Inside the junction box the terminal labeled EARTH GND is internally connected to the antistatic mounting post. This terminal should be connected to an earth ground (Refer to wiring diagram).

Initial installation is most easily done with two people; one to adjust the instrument position and the other to observe the indicating device. After initial installation, the instrument can be removed and returned to its mounting without realigning the vane since the orientation ring preserves the wind direction reference. Install the Wind Monitor following these steps:

1. MOUNT WIND MONITOR
  - a) Place orientation ring on mounting post. Do Not tighten band clamp yet.
  - b) Place Wind Monitor on mounting post. Do Not tighten band clamp yet.
2. CONNECT SENSOR CABLE
  - a) Slide junction box cover up.
  - b) Route cable thru strain relief opening at bottom of junction box. Secure cable by tightening packing nut.
  - c) Connect sensor cable to terminals. See wiring diagram.
  - d) Slide junction box cover down.
3. ALIGN VANE
  - a) Connect instrument to an indicator.
  - b) Choose a known wind direction reference point on the horizon.
  - c) Sighting down instrument centerline, point nose cone at reference point on horizon.
  - d) While holding vane in position, slowly turn base until indicator shows proper value.
  - e) Tighten mounting post band clamp.
  - f) Engage orientation ring indexing pin in notch at instrument base.
  - g) Tighten orientation ring band clamp.

## CALIBRATION

The Wind Monitor is fully calibrated before shipment and should require no adjustments. Recalibration may be necessary after some maintenance operations. Periodic calibration checks are desirable and may be necessary where the instrument is used in programs which require auditing of sensor performance.

Accurate wind direction calibration requires a Model 18112 Vane Angle Bench Stand. Begin by connecting the instrument to a signal conditioning circuit which has some method of indicating azimuth value. This may be a display which shows azimuth values in angular degrees or simply a voltmeter monitoring the output. Orient the base with the junction box at 180°. Visually align the vane with the crossmarkings and observe the indicator output. If the vane position and indicator do not agree within 5°, adjust the potentiometer coupling inside the main housing. Details for making this adjustment appear in the MAINTENANCE, potentiometer replacement outline, step 7.

It is important to note that, while the sensor mechanically rotates through 360°, the full scale wind direction signal from the instrument occurs at 355°. The signal conditioning electronics must be adjusted accordingly. For example, in a circuit where 0 to 1.000 VDC represents 0° to 360°, the output must be adjusted for 0.986 VDC when the instrument is at 355°. ( $355^\circ/360^\circ \times 1.000 \text{ volts} = 0.986 \text{ volts}$ )

Wind speed calibration is determined by propeller pitch and the output characteristics of the transducer. Calibration formulas showing wind speed vs. propeller rpm and output frequency are included below. Standard accuracy is  $\pm 0.3 \text{ m/s}$  (0.6mph). For greater accuracy, the device must be individually calibrated in comparison with a wind speed standard. Contact the factory or your supplier to schedule a NIST (National Institute of Standards & Technology) traceable wind tunnel calibration in our facility.

To calibrate wind system electronics using a signal from the instrument, temporarily remove the propeller and connect an Anemometer Drive to the propeller shaft. Apply the appropriate calibration formula to the calibrating motor rpm and adjust the electronics for the proper value. For example, with the propeller shaft turning at 3600 rpm adjust an indicator to display 18.4 meters per second. ( $3600 \text{ rpm} \times 0.00512 \text{ m/s/rpm} = 18.4 \text{ m/s}$ ).

### CALIBRATION FORMULAS

#### Model 05305 Wind Monitor-AQ w / 08254 Propeller

WIND SPEED vs PROPELLER RPM	
m/s	= 0.00512 x rpm
knots	= 0.00995 x rpm
mph	= 0.01145 x rpm
km/h	= 0.01843 x rpm

WIND SPEED vs OUTPUT FREQUENCY	
m/s	= 0.1024 x Hz
knots	= 0.1990 x Hz
mph	= 0.2290 x Hz
km/h	= 0.3686 x Hz

## **MAINTENANCE**

---

Given proper care, the Wind Monitor should provide years of service. The only components likely to need replacement due to normal wear are the precision ball bearings and the wind direction potentiometer. Only a qualified instrument technician should perform the replacement. If service facilities are not available, return the instrument to the company. Refer to the drawings to become familiar with part names and locations. The asterisk \* which appears in the following outlines is a reminder that maximum torque on all set screws is 80 oz-in.

### **POTENTIOMETER REPLACEMENT**

---

The potentiometer has a life expectancy of fifty million revolutions. As it becomes worn, the element may begin to produce noisy signals or become nonlinear. When signal noise or non-linearity becomes unacceptable, replace the potentiometer. Refer to exploded view drawing and proceed as follows:

1. REMOVE MAIN HOUSING
  - a) Unscrew nose cone from main housing. Set o-ring aside for later use.
  - b) Gently push main housing latch.
  - c) While pushing latch, lift main housing up and remove it from vertical shaft bearing rotor.
2. UNSOLDER TRANSDUCER WIRE
  - a) Slide junction box cover up, exposing circuit board.
  - b) Remove screws holding circuit board.
  - c) Unsolder three potentiometer wires (white, green, black), two wind speed coil wires (red, black), and earth ground wire (red) from board.
3. REMOVE POTENTIOMETER
  - a) Loosen set screw on potentiometer coupling and remove it from potentiometer adjust thumbwheel.
  - b) Loosen set screw on potentiometer adjust thumbwheel and remove it from potentiometer shaft extension.
  - c) Loosen two set screws at base of transducer assembly and remove assembly from vertical shaft.
  - d) Unscrew potentiometer housing from potentiometer mounting & coil assembly.
  - e) Push potentiometer out of potentiometer mounting & coil assembly by applying firm but gentle pressure on potentiometer shaft extension.
  - f) Loosen set screw on potentiometer shaft extension and remove it from potentiometer shaft.
4. INSTALL NEW POTENTIOMETER
  - a) Place potentiometer shaft extension on new potentiometer (Gap 0.040") and tighten set screw\*.
  - b) Push new potentiometer into potentiometer mounting & coil assembly.
  - c) Feed potentiometer and coil wires through hole in bottom of potentiometer housing.
  - d) Screw potentiometer housing onto potentiometer mounting & coil assembly. Apply a small amount of silicone sealant on threads.
  - e) Gently pull transducer wires through bottom of potentiometer housing to take up any slack. Apply a small amount of silicone sealant around hole.
  - f) Install transducer assembly on vertical shaft allowing 0.5 mm (0.020") clearance from vertical bearing. Tighten set screws\* at bottom of transducer assembly.
  - g) Place potentiometer adjust thumbwheel on potentiometer shaft extension and tighten set screw\*.
  - h) Place potentiometer coupling on potentiometer adjust thumbwheel. Do Not tighten set screw yet.

### 5. RECONNECT TRANSDUCER WIRES

- a) Using needle-nose pliers or a paper clip bent to form a small hook, gently pull transducer wires through hole in junction box.
- b) Solder wires to circuit board according to wiring diagram. Observe color code.
- c) Secure circuit board in junction box using two screws removed in step 2b. Do not overtighten.

### 6. REPLACE MAIN HOUSING

- a) Place main housing over vertical shaft bearing rotor. Be careful to align indexing key and channel in these two assemblies.
- b) Place main housing over vertical shaft bearing rotor until potentiometer coupling is near top of main housing.
- c) Turn potentiometer adjust thumbwheel until potentiometer coupling is oriented to engage ridge in top of main housing. Set screw on potentiometer coupling should be facing the front opening.
- d) With potentiometer coupling properly oriented, continue pushing main housing onto vertical shaft bearing rotor until main housing latch locks into position with a "click".

### 7. ALIGN VANE

- a) Connect excitation voltage and signal conditioning electronics to terminal strip according to wiring diagram.
- b) With mounting post held in position so junction box is facing due south, orient vane to a known angular reference. Details appear in CALIBRATION section.
- c) Reach in through front of main housing and turn potentiometer adjust thumbwheel until signal conditioning system indicates proper value.
- d) Tighten set screw\* on potentiometer coupling.

### 8. REPLACE NOSE CONE

- a) Screw nose cone into main housing until o-ring seal is seated. Be certain threads are properly engaged to avoid cross-threading.

## **FLANGE BEARING REPLACEMENT**

---

If anemometer bearings become noisy or wind speed threshold increases above an acceptable level, bearings may need replacement. Check anemometer bearing condition using a Model 18310 Propeller Torque Disc. Bearings are replaced as follows.

### 1. REMOVE OLD BEARINGS

- a) Unscrew nose cone. Set o-ring aside for later use.
- b) Loosen set screw on magnet shaft collar and remove magnet.
- c) Slide propeller shaft out of nose cone assembly.
- d) Remove front bearing cap which covers front bearing.
- e) Remove both front and rear bearings from nose cone assembly. Insert edge of a pocket knife under bearing flange and lift it out.

### 2. INSTALL NEW BEARINGS

- a) Insert new front and rear bearings into nose cone.
- b) Replace front bearing cap.
- c) Carefully slide propeller shaft thru bearings.
- d) Place magnet on propeller shaft allowing 0.5 mm (0.020") clearance from rear bearing.
- e) Tighten set screw\* on magnet shaft collar.
- f) Screw nose cone into main housing until o-ring seal is seated. Be certain threads are properly engaged to avoid cross-threading.

\*Max set screw torque 80 oz-in

## **VERTICAL SHAFT BEARING REPLACEMENT**

---

Vertical shaft bearings are much larger than the anemometer bearings. Ordinarily, these bearings will require replacement less frequently than anemometer bearings. Check bearing condition using a Model 18331 Vane Torque Gauge.

Since this procedure is similar to POTENTIOMETER REPLACEMENT, only the major steps are listed here.

1. REMOVE MAIN HOUSING
2. UNSOLDER TRANSDUCER WIRES AND REMOVE TRANSDUCER ASSEMBLY Loosen set screws at base of transducer assembly and remove entire assembly from vertical shaft.
3. REMOVE VERTICAL SHAFT BEARING ROTOR by sliding it upward off vertical shaft.
4. REMOVE OLD VERTICAL BEARINGS AND INSTALL NEW BEARINGS. When inserting new bearings, be careful not to apply pressure to bearing shields.
5. REPLACE VERTICAL SHAFT BEARING ROTOR.
6. REPLACE TRANSDUCER & RECONNECT WIRES
7. REPLACE MAIN HOUSING
8. ALIGN VANE
9. REPLACE NOSE CONE

## **WARRANTY**

---

This product is warranted to be free of defects in materials and construction for a period of 12 months from date of initial purchase. Liability is limited to repair or replacement of defective item. A copy of the warranty policy may be obtained from R. M. Young Company.

## **CE COMPLIANCE**

---

This product has been tested and shown to comply with European CE requirements for the EMC Directive. Please note that shielded cable must be used.

### **Declaration of Conformity**

**Application of Council Directives:**  
89/336/EEC

**Standards to which Conformity is Declared:**  
EN 50082-1 (IEC 801-2, 3, 4)

**Manufacturer's Name and Address:**  
R. M. Young Company  
Traverse City, MI, 49686, USA

**Importer's Name and Address:**  
See Shipper or Invoice

**Type of Equipment:**  
Meteorological Instruments

**Model Number / Year of Manufacture:**  
05305/1996

I, the undersigned, hereby declare that the equipment specified conforms to the above Directives and Standards.

**Date / Place:**  
Traverse City, Michigan, USA February 19, 1996



David Poinsett  
R & D Manager, R. M. Young Company



## **Appendix C**

### Cable and Wiring Diagrams



MODEL 05106C

WIND MONITOR-MA/MARINE MODEL WIND SENSOR W/CONNECTOR

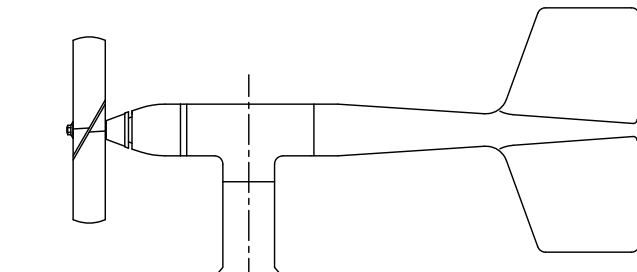

STATIONARY WIND SPEED TRANSDUCER COIL:  
 ROTATING MAGNET ON PROPELLER SHAFT INDUCES AC SIGNAL WITH FREQUENCY DIRECTLY PROPORTIONAL TO WIND SPEED. THREE CYCLES OF OUTPUT REPRESENTS ONE PROPELLER REVOLUTION.

WIND DIRECTION POTENTIOMETER:  
 10K OHMS, 0.25% LINEARITY, 355° FUNCTION ANGLE, 1 WATT @ 40°C, DERATED TO 0 WATTS @ 125° C

SIX POLE PERMANENT MAGNET MOUNTED ON PROPELLER SHAFT

IMPORTANT - THE WIND MONITOR MOUNTING MUST BE EARTH GROUNDED.

NOTE:  
 POTENTIOMETER WIRES ARE 28 AWG.  
 WIND SPEED COIL WIRES ARE 22 AWG.

MULTI-CONDUCTOR CABLE  
 1M (3.3 FT) CABLE,  
 6 CONDUCTOR, 20 AWG, SHIELDED

PC BOARD LOCATED IN MOUNTING POST

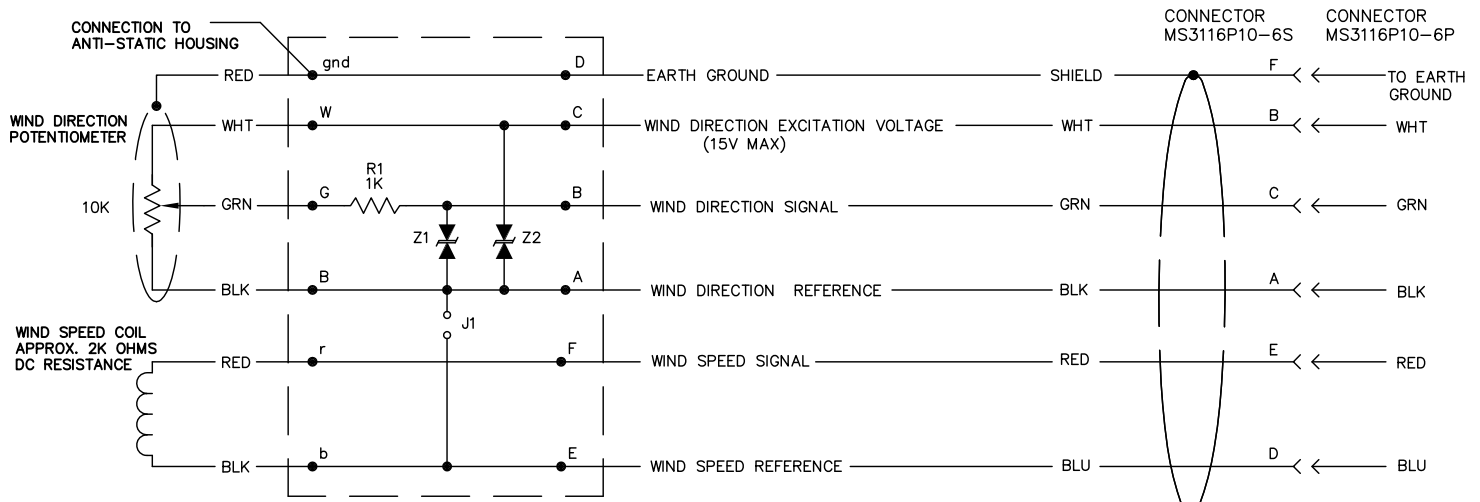
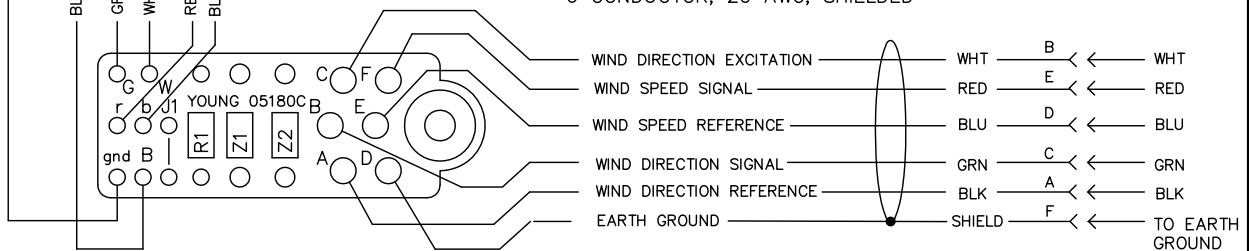

Z1 AND Z2 ARE TRANSZORB TRANSIENT PROTECTION DEVICES.



MODIFICATIONS TO STANDARD 05106:  
 1. USE 05271 CABLE ASSEMBLY.

MODEL 05106C WIND MONITOR-MA	DWG C	PRD 10/95
MARINE MODEL W/CONNECTOR	DWN JMT	DWN 08/05
CABLE & WIRING DIAGRAM	CHK Y.C.	w05106c(c)CSC
R.M. YOUNG CO. TRAVERSE CITY, MI 49686 U.S.A. 231-946-3980		



MODEL 05106C-10  
WIND MONITOR-MA/MARINE MODEL WIND SENSOR W/CONNECTOR

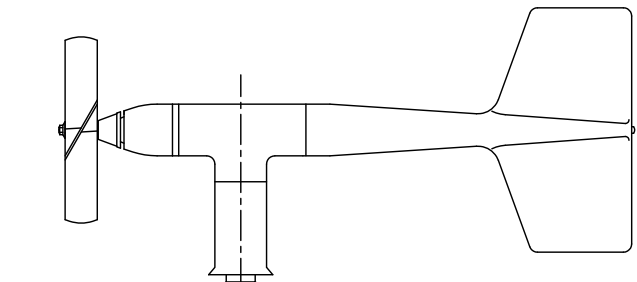

STATIONARY WIND SPEED TRANSDUCER COIL:  
ROTATING MAGNET ON PROPELLER SHAFT INDUCES AC SIGNAL WITH FREQUENCY DIRECTLY PROPORTIONAL TO WIND SPEED. THREE CYCLES OF OUTPUT REPRESENTS ONE PROPELLER REVOLUTION.

WIND DIRECTION POTENTIOMETER:  
10K OHMS, 0.25% LINEARITY, 355° FUNCTION ANGLE, 1 WATT @ 40°C, DERATED TO 0 WATTS @ 125° C

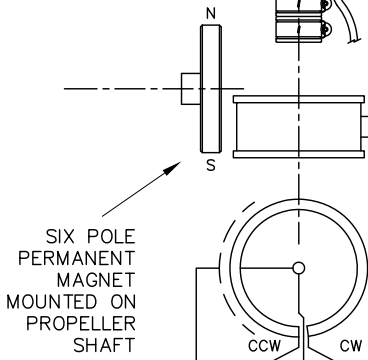

**IMPORTANT - THE WIND MONITOR MOUNTING MUST BE EARTH GROUNDED.**

NOTE:  
POTENTIOMETER WIRES ARE 28 AWG.  
WIND SPEED COIL WIRES ARE 22 AWG.

MULTI-CONDUCTOR CABLE  
1M (3.3 FT) CABLE,  
6 CONDUCTOR, 20 AWG, SHIELDED

PC BOARD LOCATED IN MOUNTING POST

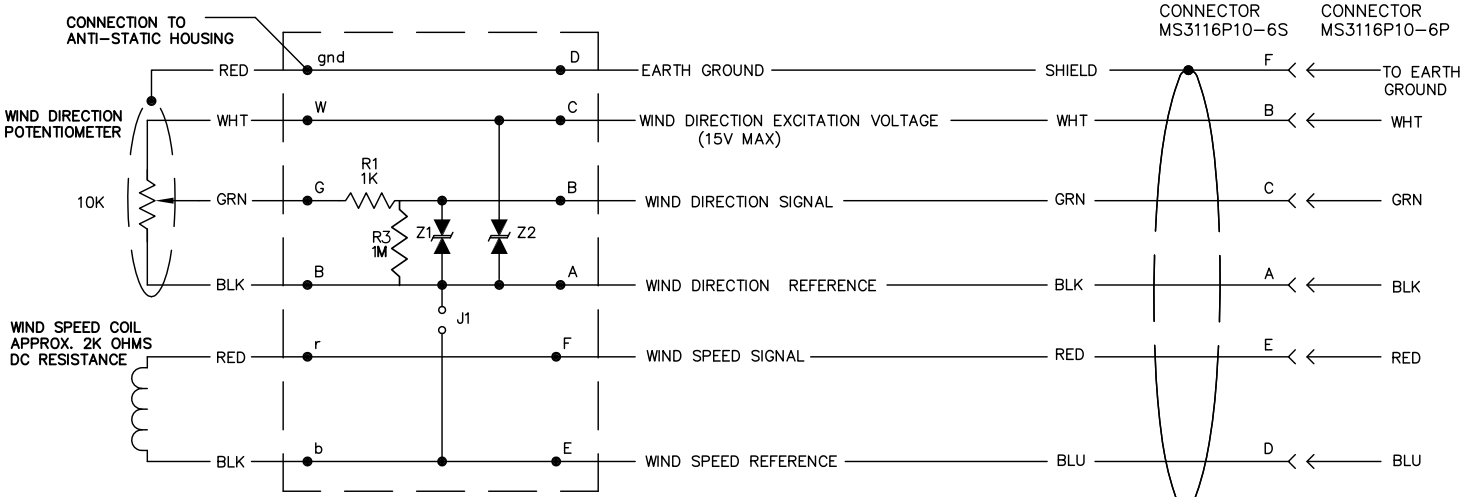
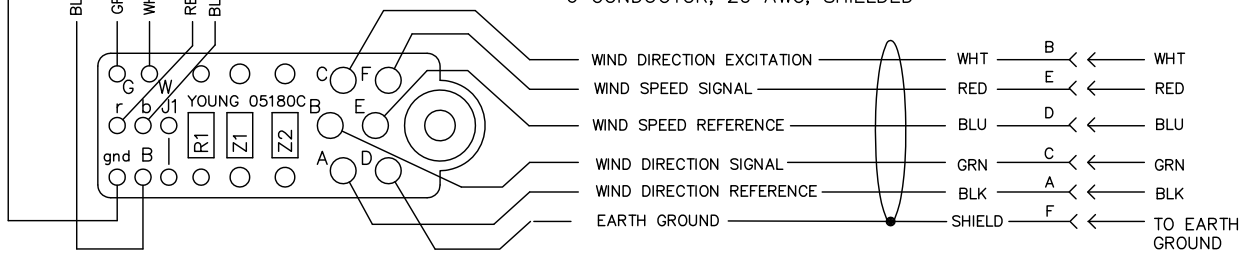

Z1 AND Z2 ARE TRANSZORB TRANSIENT PROTECTION DEVICES.



MODIFICATIONS TO STANDARD 05106:  
1. USE 05271 CABLE ASSEMBLY.

MODEL 05106C WIND MONITOR-MA	DWG C	PRD 10/95
MARINE MODEL W/CONNECTOR	DWN JMT	DWN 08/05
CABLE & WIRING DIAGRAM	CHK Y.C.	w05106c(c)CSC
R.M. YOUNG CO. TRAVERSE CITY, MI 49686 U.S.A. 231-946-3980		



MODEL 05106  
WIND MONITOR-MA/MARINE MODEL WIND SENSOR

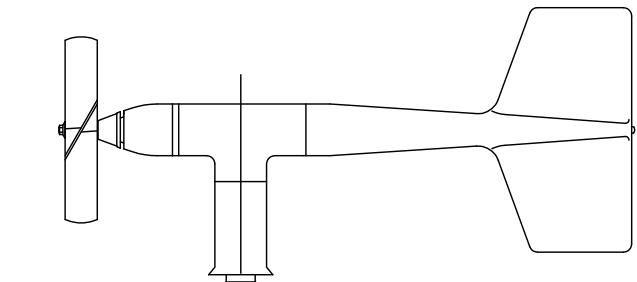

STATIONARY WIND SPEED TRANSDUCER COIL:  
ROTATING MAGNET ON PROPELLER SHAFT INDUCES AC SIGNAL WITH FREQUENCY DIRECTLY PROPORTIONAL TO WIND SPEED. THREE CYCLES OF OUTPUT REPRESENTS ONE PROPELLER REVOLUTION.

WIND DIRECTION POTENTIOMETER:  
10K OHMS, 0.25% LINEARITY, 355° FUNCTION ANGLE, 1 WATT @ 40°C, DERATED TO 0 WATTS @ 125° C

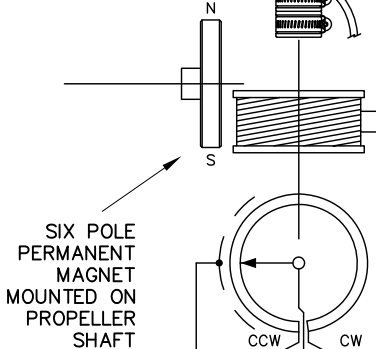

IMPORTANT - THE WIND MONITOR MOUNTING MUST BE EARTH GROUNDED.

NOTE:  
POTENTIOMETER WIRES ARE 28 AWG.  
WIND SPEED COIL WIRES ARE 22 AWG.

MULTI-CONDUCTOR CABLE  
3M (9.8 FT) CABLE,  
6 CONDUCTOR, 20 AWG, SHIELDED

PC BOARD LOCATED IN MOUNTING POST

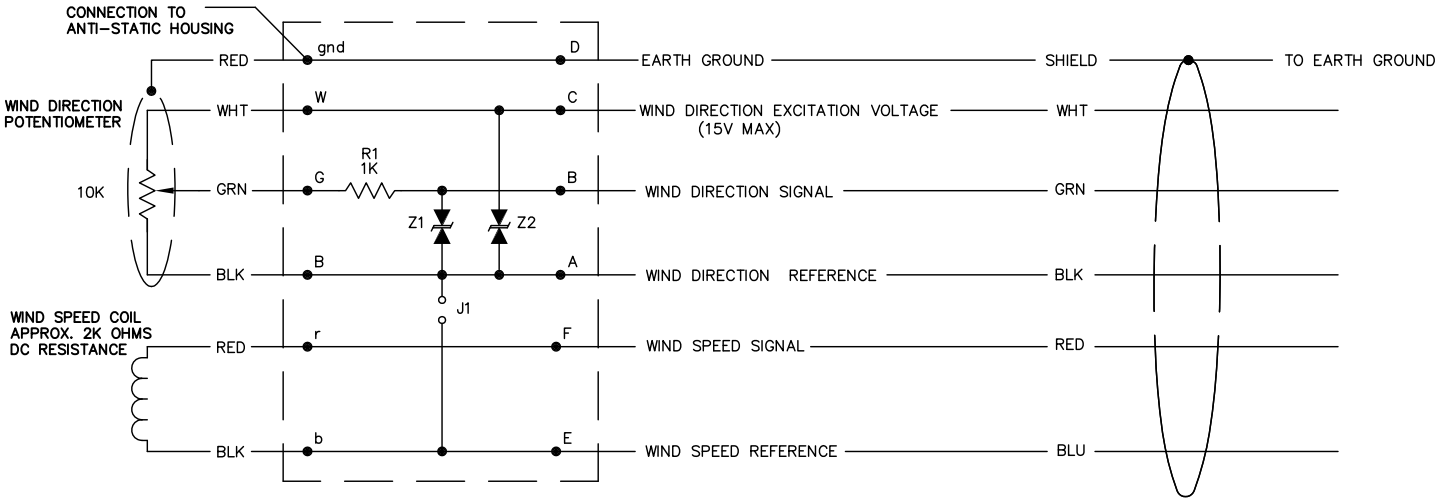
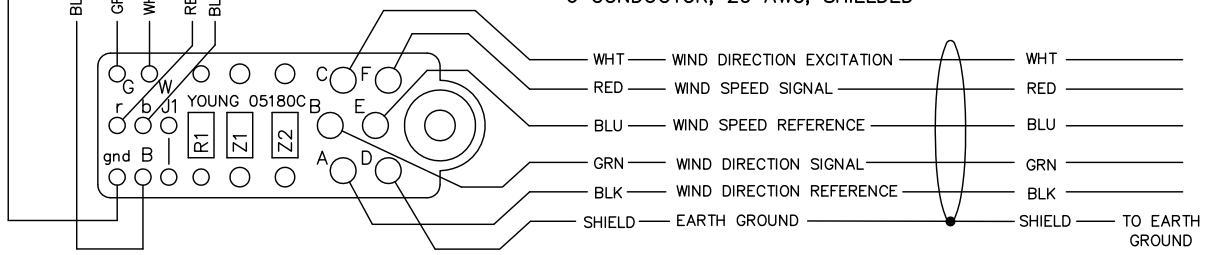

Z1 AND Z2 ARE TRANSORB TRANSIENT PROTECTION DEVICES.



MODEL 05106 WIND MONITOR-MA	DWG C	PRD 09/03
MARINE MODEL	DWN JMT	DWN 08/05
CABLE & WIRING DIAGRAM	CHK Y.C.	w05106(c)CSC
R.M. YOUNG CO. TRAVERSE CITY, MI 49686 U.S.A. 231-946-3980		



MODEL 05106-10  
WIND MONITOR-MA/MARINE MODEL WIND SENSOR

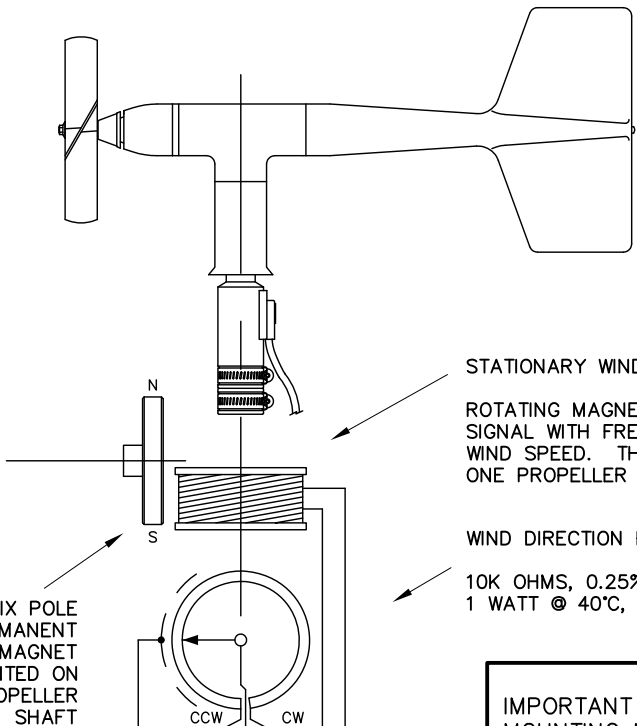

**IMPORTANT - THE WIND MONITOR MOUNTING MUST BE EARTH GROUNDED.**

NOTE:  
POTENTIOMETER WIRES ARE 28 AWG.  
WIND SPEED COIL WIRES ARE 22 AWG.

PC BOARD LOCATED IN MOUNTING POST

MULTI-CONDUCTOR CABLE  
3M (9.8 FT) CABLE,  
6 CONDUCTOR, 20 AWG, SHIELDED

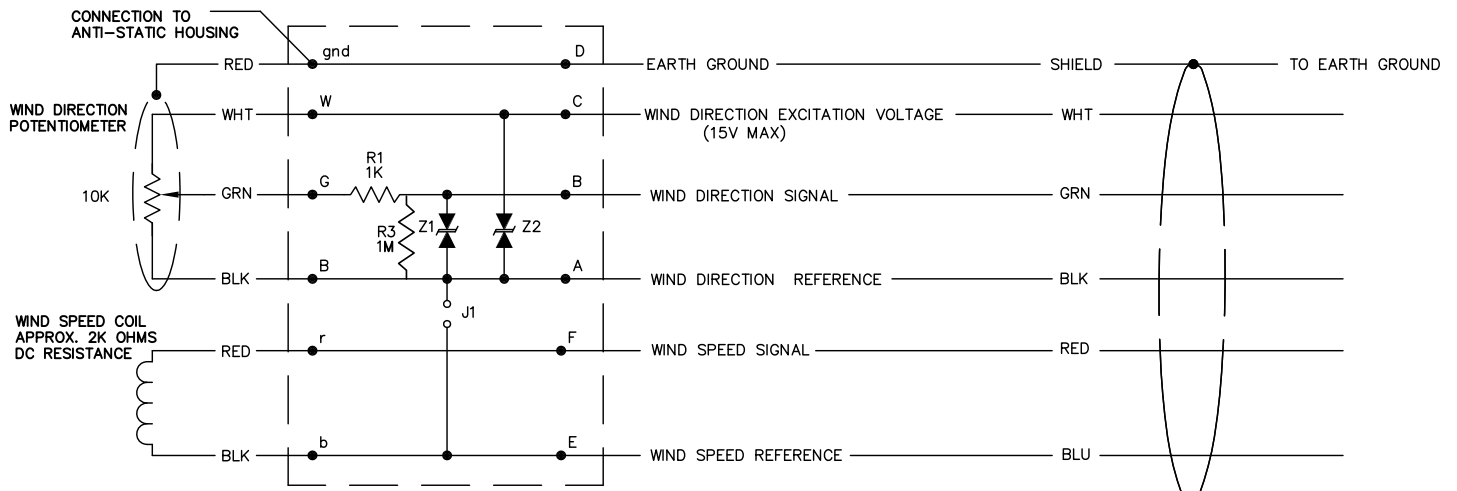
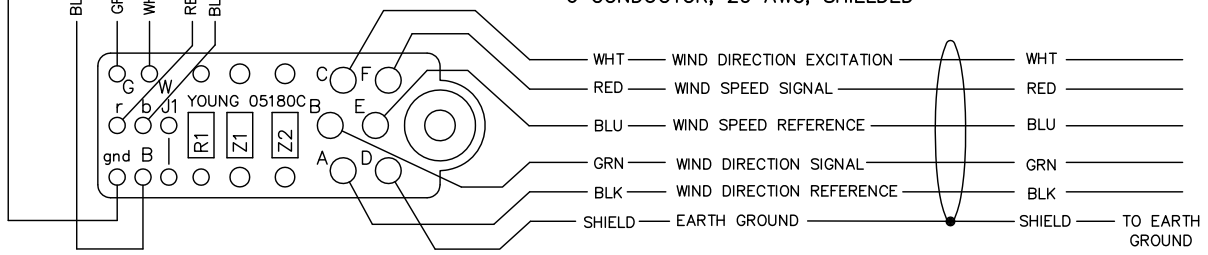

MODEL 05106 WIND MONITOR-MA	DWG C	PRD 09/03
MARINE MODEL	DWN JMT	DWN 08/05
CABLE & WIRING DIAGRAM	CHK Y.C.	w05106(c)CSC
R.M. YOUNG CO. TRAVERSE CITY, MI 49686 U.S.A. 231-946-3980		

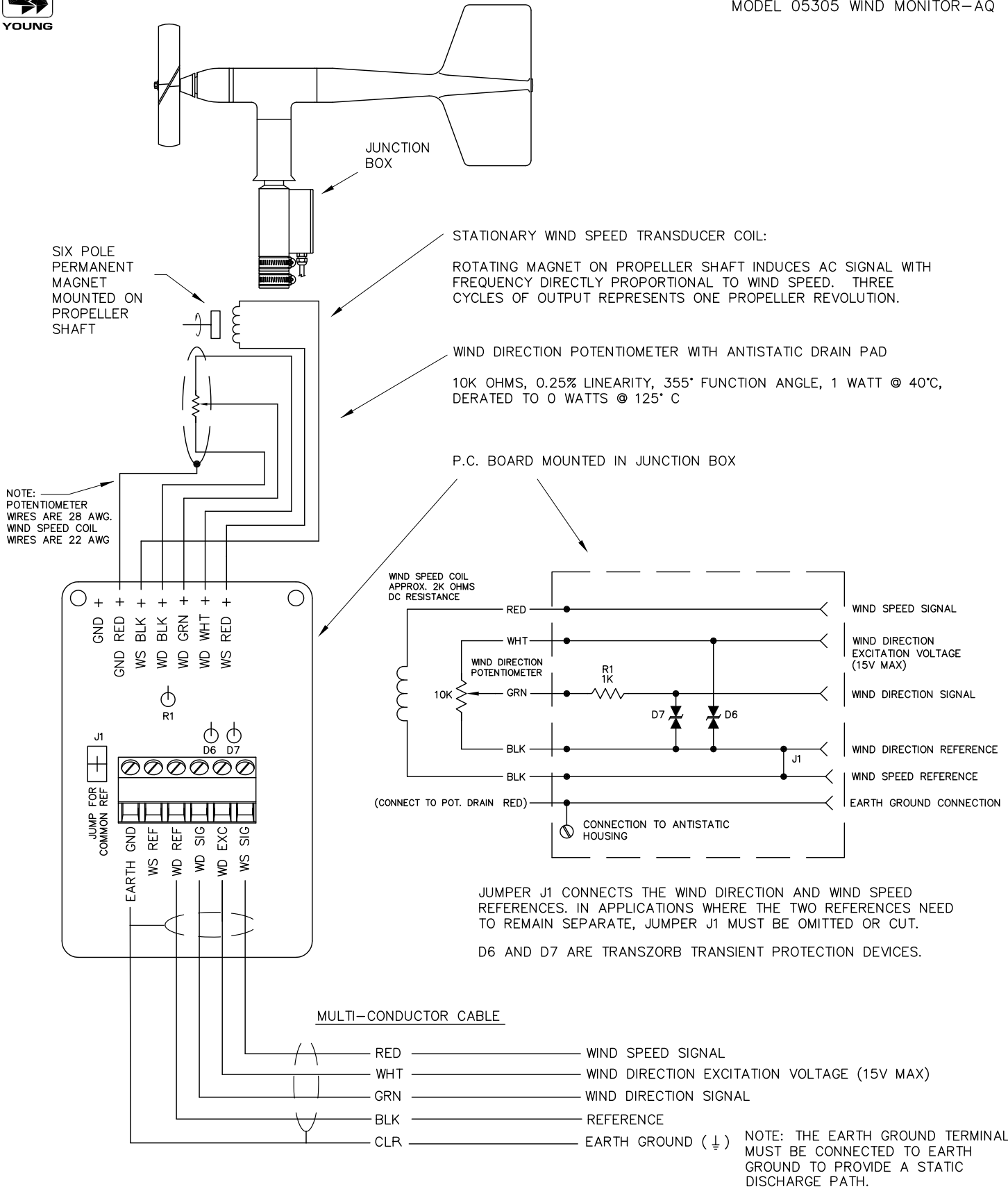

NOTE:  
POTENTIOMETER  
WIRES ARE 28 AWG.  
WIND SPEED COIL  
WIRES ARE 22 AWG

STATIONARY WIND SPEED TRANSDUCER COIL:  
ROTATING MAGNET ON PROPELLER SHAFT INDUCES AC SIGNAL WITH FREQUENCY DIRECTLY PROPORTIONAL TO WIND SPEED. THREE CYCLES OF OUTPUT REPRESENTS ONE PROPELLER REVOLUTION.

WIND DIRECTION POTENTIOMETER WITH ANTISTATIC DRAIN PAD  
10K OHMS, 0.25% LINEARITY, 355° FUNCTION ANGLE, 1 WATT @ 40°C, DERATED TO 0 WATTS @ 125° C

P.C. BOARD MOUNTED IN JUNCTION BOX

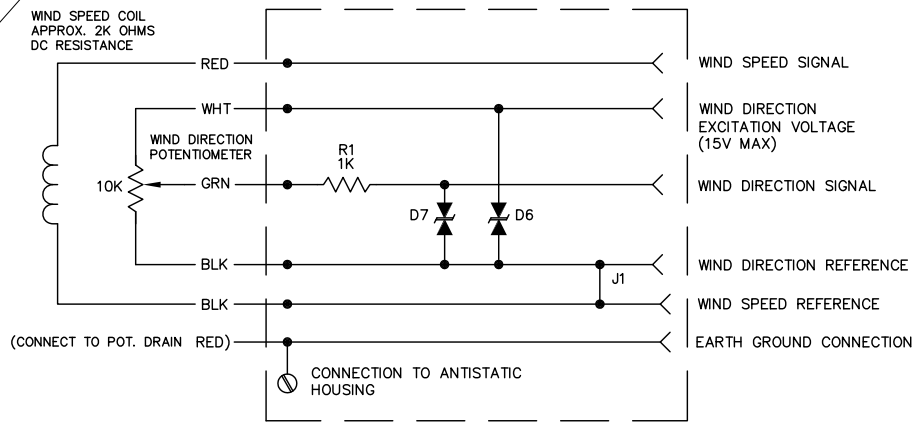
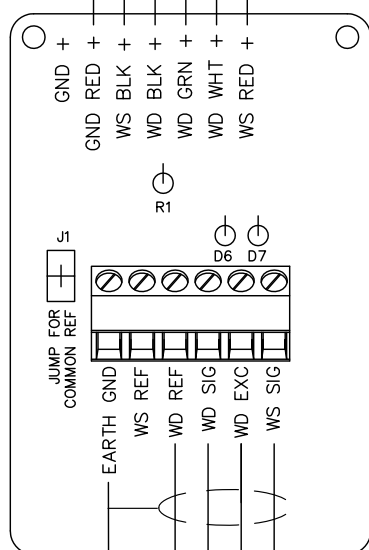

JUMPER J1 CONNECTS THE WIND DIRECTION AND WIND SPEED REFERENCES. IN APPLICATIONS WHERE THE TWO REFERENCES NEED TO REMAIN SEPARATE, JUMPER J1 MUST BE OMITTED OR CUT.

D6 AND D7 ARE TRANSORB TRANSIENT PROTECTION DEVICES.

MULTI-CONDUCTOR CABLE

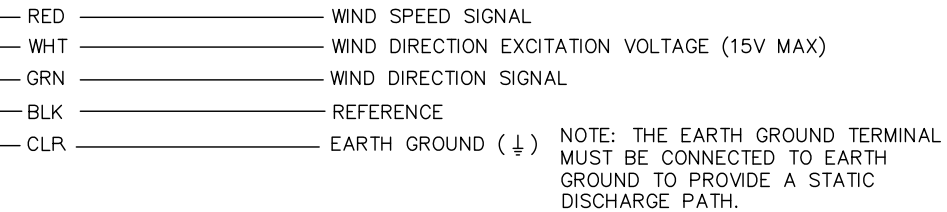

05103 WIND MONITOR	DWG B	PRD 02/98
CABLE & WIRING DIAGRAM	DWN JMT	DWN 08/05
	CHK Y.C.	W05103(B)CSC
R.M. YOUNG CO. TRAVERSE CITY, MI 49686 U.S.A. 231-946-3980		



MODEL 05103 WIND MONITOR  
MODEL 05305 WIND MONITOR-AQ

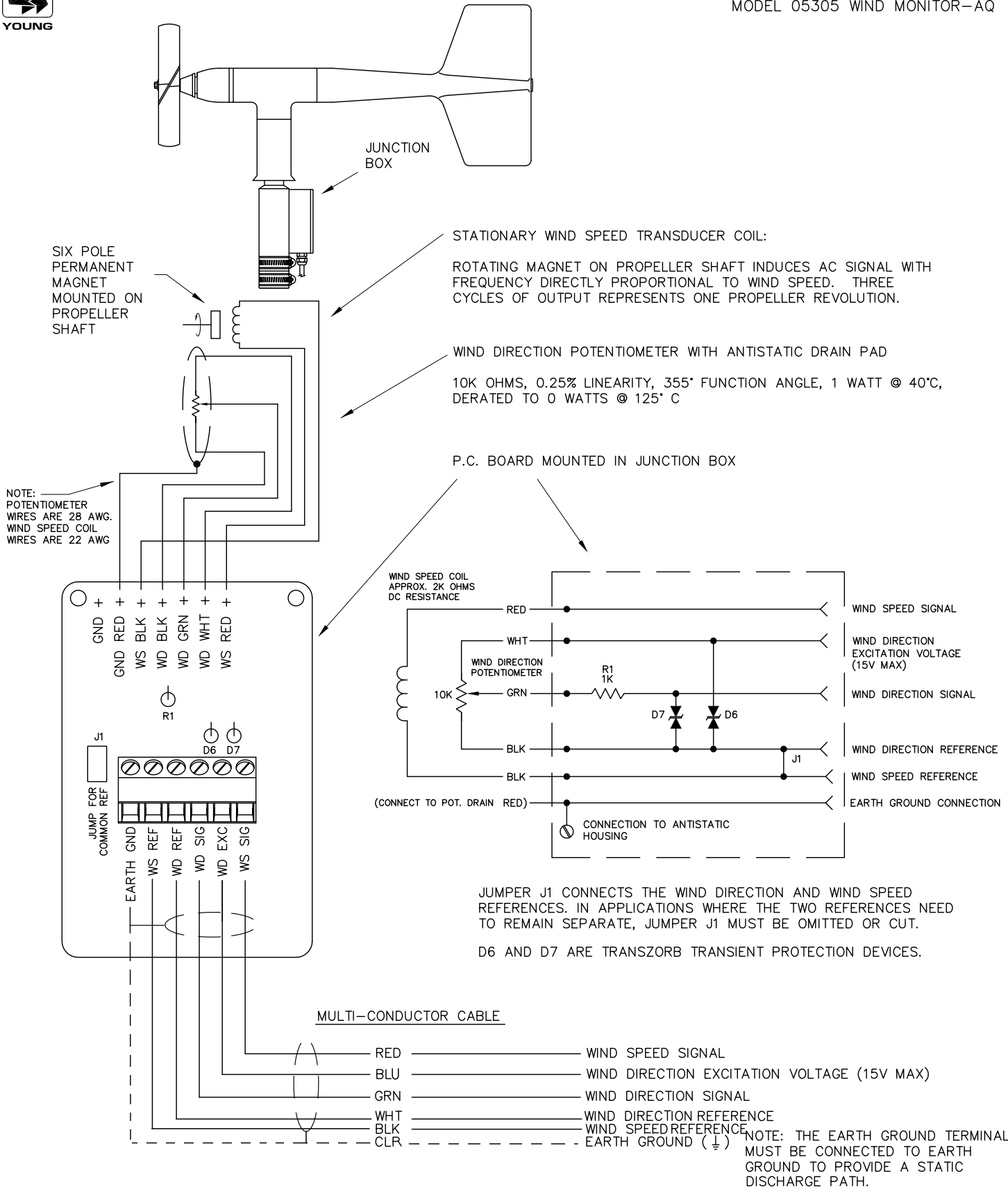

05103 WIND MONITOR	DWG B	PRD 02/98
CABLE & WIRING DIAGRAM	DWN JMT	DWN 08/05
	CHK Y.C.	W05103(B)CSC
R.M. YOUNG CO. TRAVERSE CITY, MI 49686 U.S.A. 231-946-3980		

# Appendix D

## Exploded Views and Section Views





MODEL 05106C, 05106C-10 WIND MONITOR-MA  
MARINE MODEL WIND SENSOR W/CONNECTOR

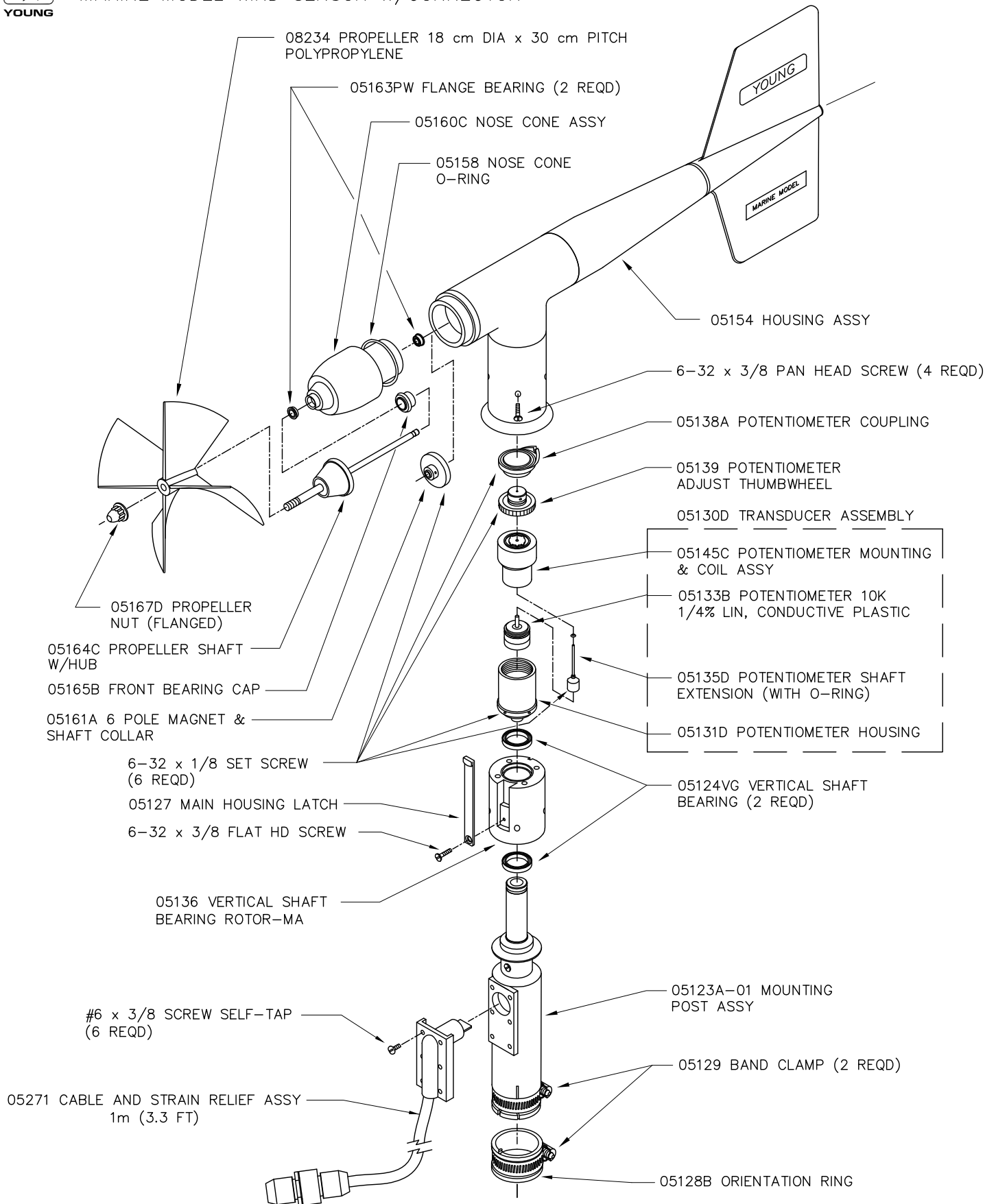

MODIFICATIONS TO STANDARD 05106:

1. USE 05271 CABLE ASSEMBLY.

MODEL 05106C WIND MONITOR-MA	DWG B	PRD 10/95
MARINE MODEL WIND SENSOR W/CONNECTOR	DWN JMT	DWN 08/05
GENERAL ASSY & REPLACEMENT PARTS	CHK Y.C.	E05106C(B)CSC
R.M. YOUNG CO. TRAVERSE CITY, MI 49686 U.S.A. 231-946-3980		



MODEL 05106,05106-10 WIND MONITOR-MA  
MARINE MODEL

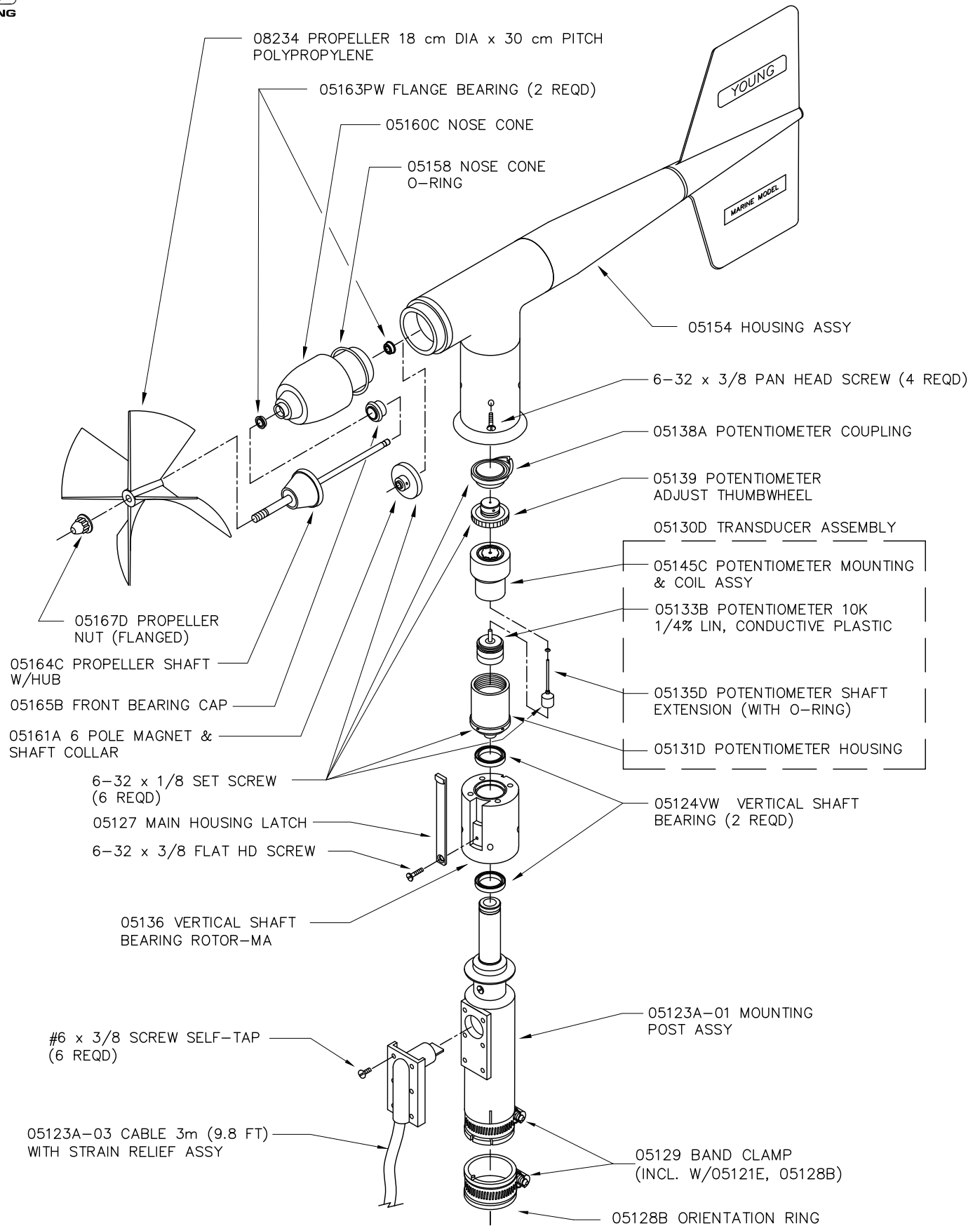

MODEL 05106 WIND MONITOR-MA	DWG D	PRD 01/94
MARINE MODEL	DWN JMT	DWN 12/05
GENERAL ASSY & REPLACEMENT PARTS	CHK Y.C.	E05106(D)CSC
R.M. YOUNG CO. TRAVERSE CITY, MI 49686 U.S.A. 231-946-3980		



MODEL 05103, 05103-10 WIND MONITOR

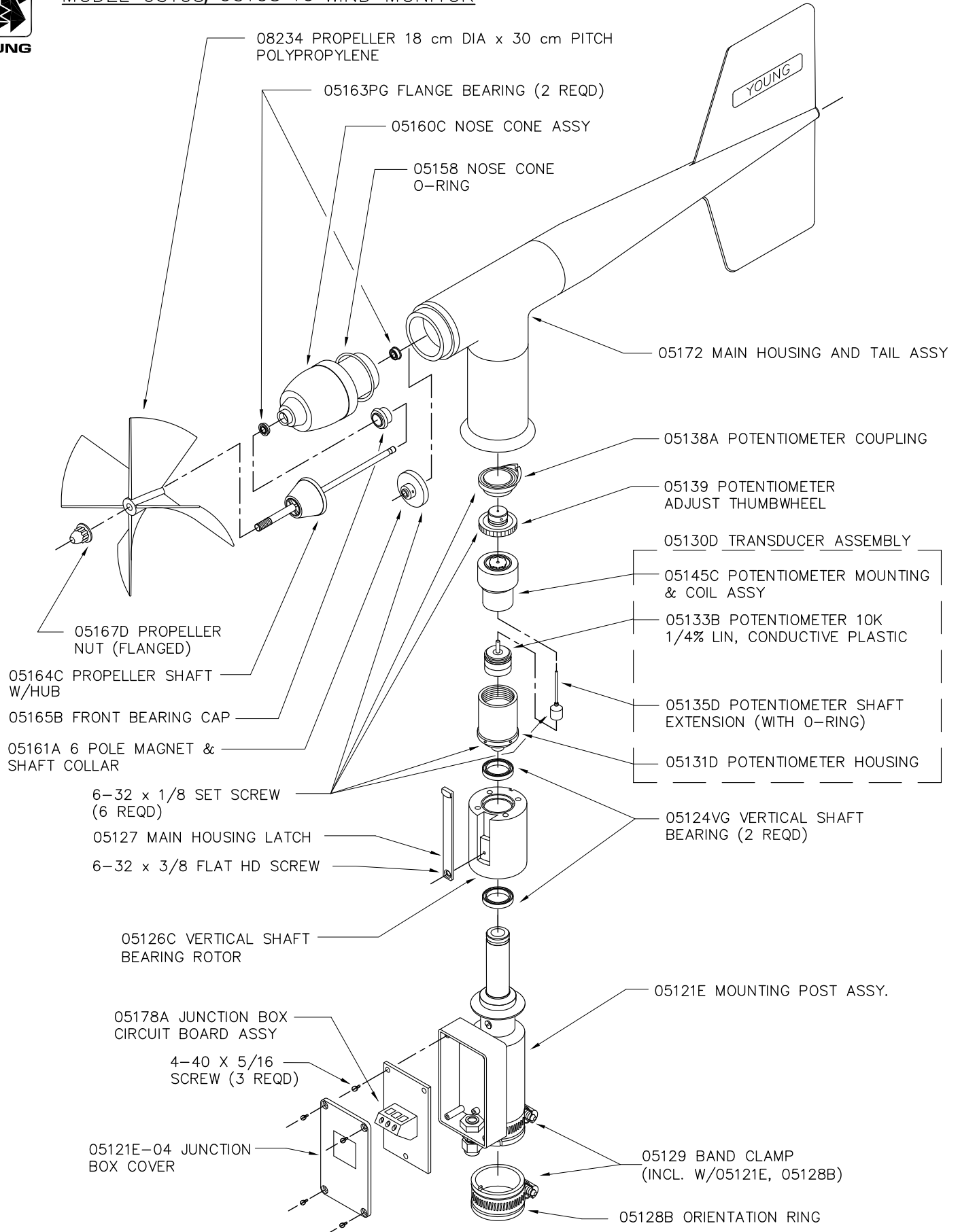

MODEL 05103 WIND MONITOR	DWG D	PRD 02/98
GENERAL ASSEMBLY & REPLACEMENT PARTS	DWN JMT	DWN 08/05
	CHK Y.C.	E05103(D)CSC
R.M. YOUNG CO. TRAVERSE CITY, MI 49686 U.S.A. 231-946-3980		



MODEL 05305, 05305-10 WIND MONITOR-AQ

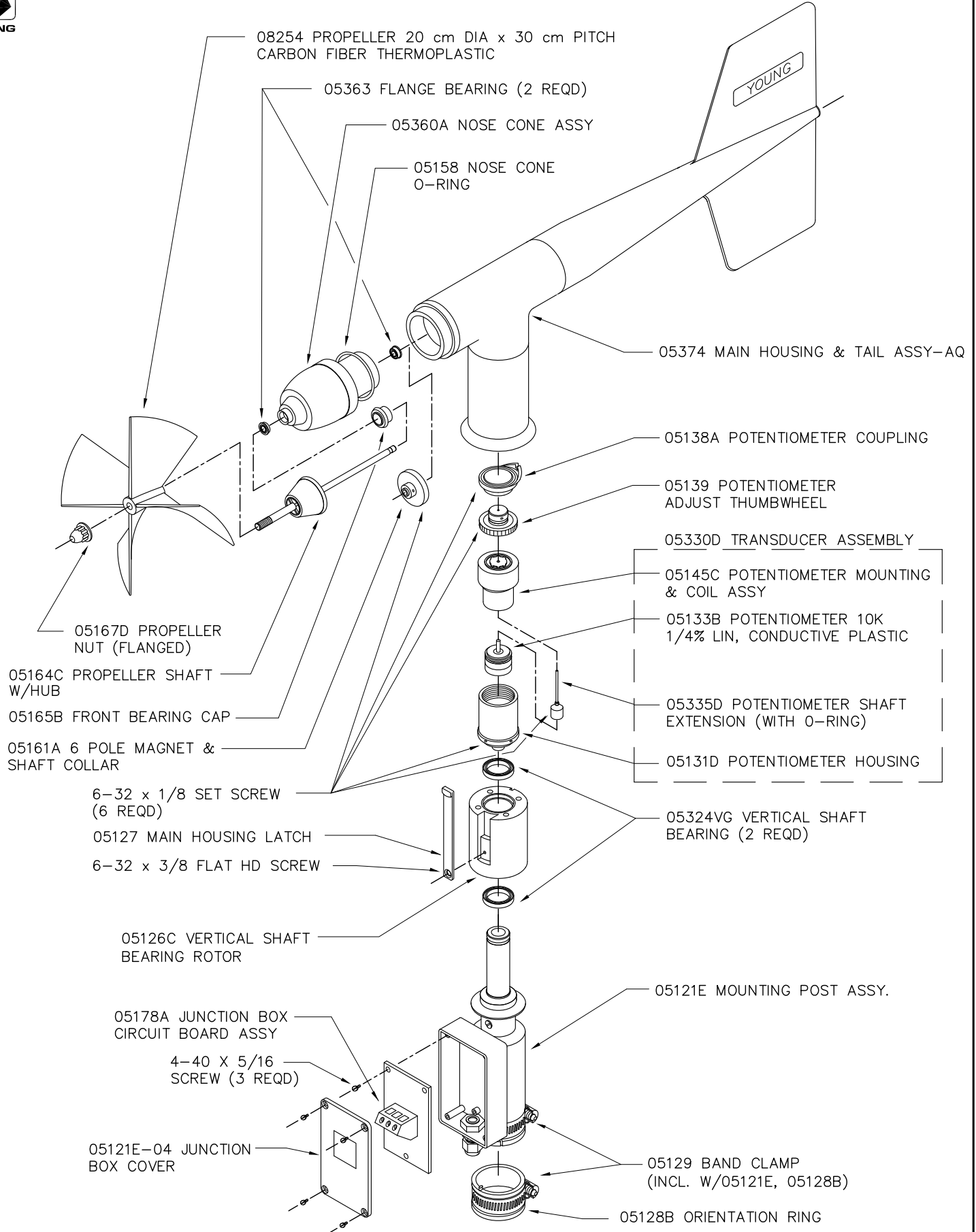

MODEL 05305 WIND MONITOR-AQ	DWG C	PRD 02/98
GENERAL ASSEMBLY & REPLACEMENT PARTS	DWN JMT	DWN 08/05
	CHK Y.C.	E05305(C)CSC
R.M. YOUNG CO. TRAVERSE CITY, MI 49686 U.S.A. 231-946-3980		



WIND MONITOR-MA 05106, 05106-10, 05106C, 05106C-10 SECTION VIEW  
 BEARING REPLACEMENT/POTENTIOMETER ADJUSTMENT

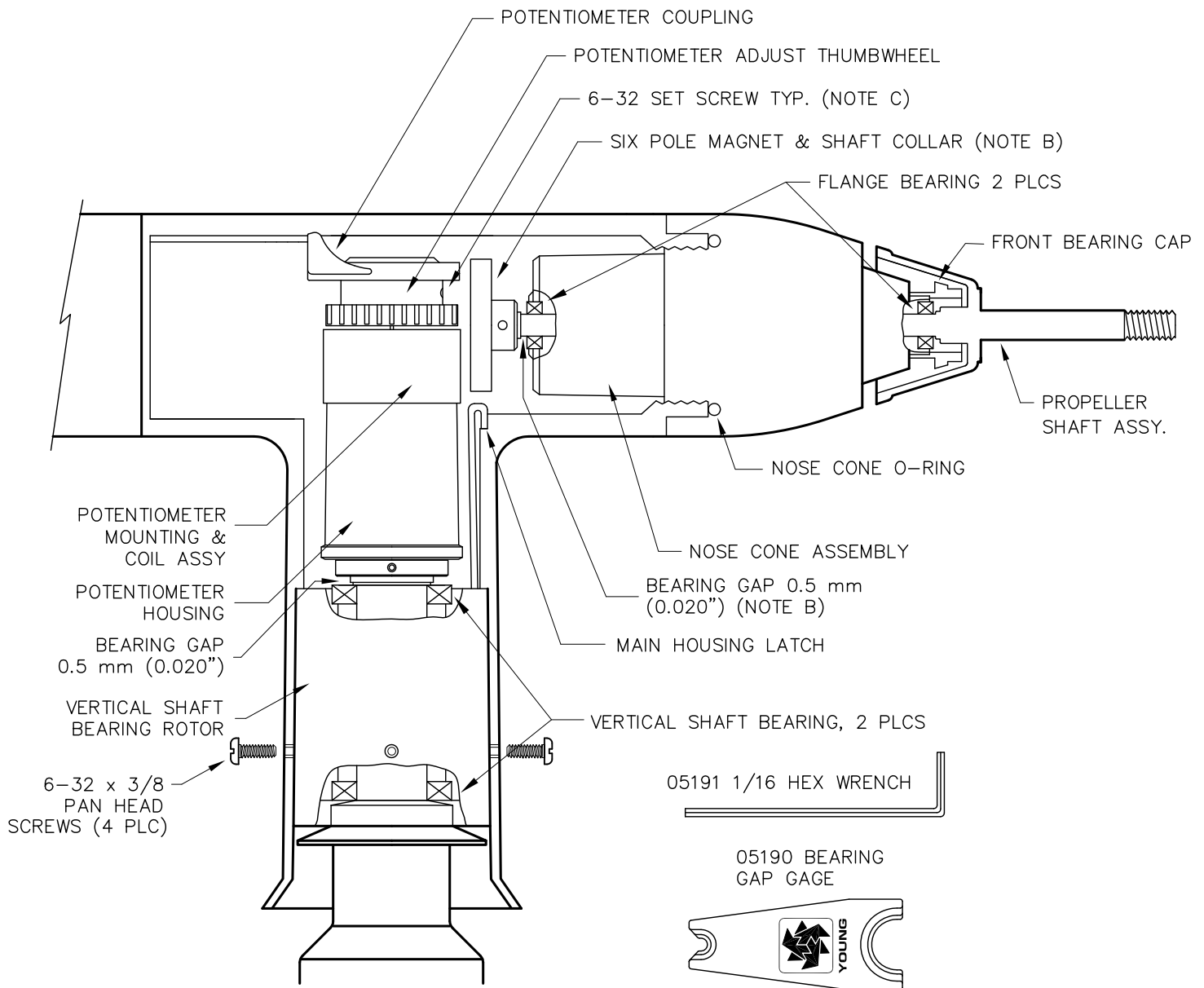

**NOTES:**

- A. TO REMOVE HOUSING – UNTHREAD NOSE CONE ASSEMBLY, REMOVE HOUSING SCREWS, PUSH MAIN HOUSING LATCH, LIFT UPWARD.
- B. TO REPLACE ANEMOMETER FLANGE BEARINGS – UNTHREAD NOSE CONE, REMOVE SIX POLE MAGNET, SLIDE PROPELLER SHAFT AND HUB ASSEMBLY FORWARD, REMOVE FRONT BEARING CAP AND FLANGE BEARINGS. AFTER BEARING REPLACEMENT, SET BEARING GAP TO 0.5mm (0.020")
- C. TO ADJUST POTENTIOMETER OUTPUT SIGNAL – REMOVE NOSE CONE, LOOSEN SET SCREW IN POTENTIOMETER COUPLING, ADJUST OUTPUT SIGNAL BY MEANS OF POTENTIOMETER ADJUSTMENT THUMBWHEEL, RE-TIGHTEN SET SCREW.

MODEL 05106 WIND MONITOR-MA	DWG B	PRD 08/00
SECTION VIEW - BEARING REPLACEMENT/ POTENTIOMETER ADJUSTMENT	DWN JMT	DWN 08/05
	CHK Y.C.	S05106(B)CSC
R.M. YOUNG CO. TRAVERSE CITY, MI 49686 U.S.A. 231-946-3980		



WIND MONITOR 05103, 05103-10, 05305, 05305-10 SECTION VIEW  
 BEARING REPLACEMENT/POTENTIOMETER ADJUSTMENT

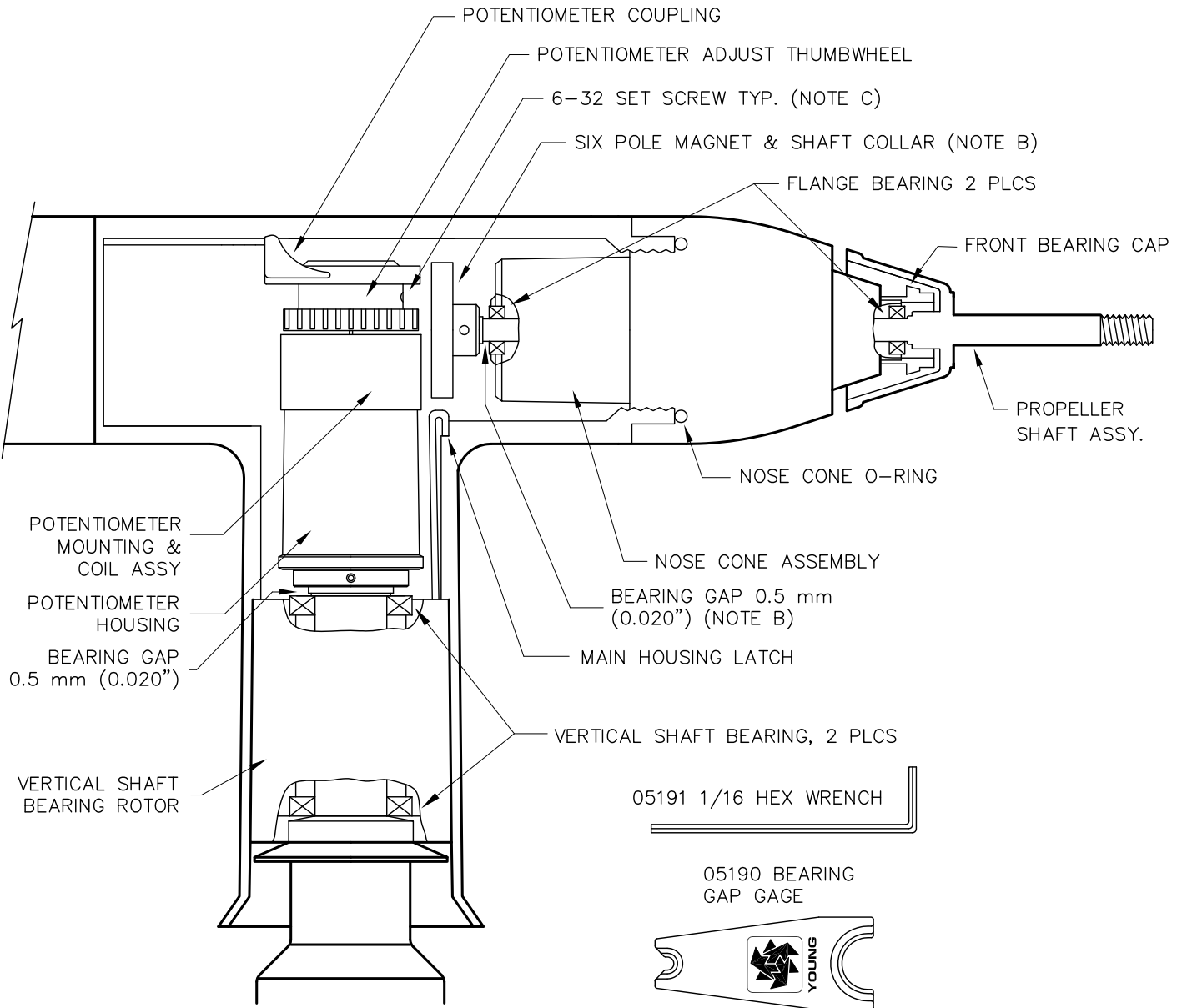

**NOTES:**

- A. TO REMOVE HOUSING – UNTHREAD NOSE CONE ASSEMBLY, PUSH MAIN HOUSING LATCH, LIFT UPWARD.
- B. TO REPLACE ANEMOMETER FLANGE BEARINGS – UNTHREAD NOSE CONE, REMOVE SIX POLE MAGNET, SLIDE PROPELLER SHAFT AND HUB ASSEMBLY FORWARD, REMOVE FRONT BEARING CAP AND FLANGE BEARINGS. AFTER BEARING REPLACEMENT, SET BEARING GAP TO 0.5mm (0.020")
- C. TO ADJUST POTENTIOMETER OUTPUT SIGNAL – REMOVE NOSE CONE, LOOSEN SET SCREW IN POTENTIOMETER COUPLING, ADJUST OUTPUT SIGNAL BY MEANS OF POTENTIOMETER ADJUSTMENT THUMBWHEEL, RE-TIGHTEN SET SCREW.

# Appendix E

## Calibration Accessories

# Calibration Accessories

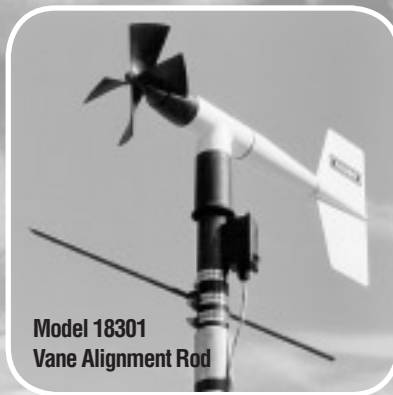



**Model 18802 Anemometer Drive** provides a convenient and accurate way to rotate an anemometer shaft at a known rate. The motor may be set to rotate clockwise or counter-clockwise at any rate between 200 and 15,000 RPM in 100 RPM increments. The LCD display is referenced to an accurate and stable quartz timebase. For completely portable operation, the unit can be operated on internal batteries. For extended operation, an AC wall adapter is included.

**Model 18811 Anemometer Drive** is identical to Model 18802 except the drive motor incorporates a gear reducer for operation in the range of 20 to 990 RPM in 10 RPM increments. The lower range is recommended for cup anemometer calibration.

**Model 18112 Vane Angle Bench Stand** is used for benchtop wind direction calibration of the Wind Monitor family of sensors. The mounting post engages the direction orientation notch on the Wind Monitor. An easy to read pointer indicates 0 to 360 degrees with 1/2 degree resolution.

**Model 18212 Vane Angle Fixture - Tower Mount** similar to the Model 18112, the tower mount feature allows use on the tower as well as the bench top. The fixture is temporarily placed on the tower between the Wind Monitor and its tower mounting. Index keys and notches are engaged to preserve direction reference.

**Model 18310 Propeller Torque Disc** checks anemometer bearing torque with 0.1 gm/cm resolution. The disc temporarily replaces the propeller for torque measurement or simple yet accurate pass/fail checks. Charts included with the unit relate torque to propeller threshold with limits for acceptable bearing performance.

**Model 18312 Cup-Wheel Torque Disc** checks cup anemometer bearing torque.

**Model 18331 Vane Torque Gauge** checks vane bearing torque of the Wind Monitor family sensors. Slip the fixture over the main housing and make simple yet accurate vane torque measurements. Charts relating vane torque to vane threshold provide limits for acceptable bearing performance.

**Model 18301 Vane Alignment Rod** helps align the vane of a wind sensor to a known direction reference during installation. The base of the device has an index key that engages the direction orientation notch in the sensor allowing the sensor to be removed without losing wind direction reference.

## Specifications

### MODEL 18802 ANEMOMETER DRIVE (Replaces 18801)

**Range:**  
200 to 15,000 RPM in 100 RPM increments

**Rotation:**  
Clockwise or Counter-Clockwise

**Display Resolution:**  
1 RPM

**Quartz Timebase Reference:**  
0.1 RPM

**Power Requirement:**  
2x9 V (alkaline or lithium) batteries  
115 VAC wall adapter included  
(230 VAC – add suffix H)

### MODEL 18811 ANEMOMETER DRIVE (Replaces 18810)

**Range:**  
20 to 990 RPM in 10 RPM increments

**Display Resolution:**  
0.1 RPM

### MODEL 18112, 18212 VANE ANGLE CALIBRATION DEVICES

**Range:**  
0 to 360 degrees

**Resolution:**  
0.5 degree

### MODEL 18310, 18312 TORQUE DISC DEVICES

**Range:**  
0 to 5.4 gm-cm

**Resolution:**  
0.1 gm-cm

### MODEL 18331 VANE TORQUE GAUGE

**Range:**  
0 to 50 gm-cm

**Resolution:**  
5 gm-cm

*Specifications subject to change without notice.*

## Ordering Information

	MODEL
ANEMOMETER DRIVE 200 to 15,000 RPM .....	18802
ANEMOMETER DRIVE 20 TO 990 RPM .....	18811
230V / 50-60 HZ INPUT POWER .....	ADD SUFFIX "H"
VANE ANGLE BENCH STAND .....	18112
VANE ANGLE FIXTURE - TOWER MOUNT .....	18212
PROPELLER TORQUE DISC .....	18310
CUP-WHEEL TORQUE DISC .....	18312
VANE TORQUE GAUGE .....	18331
VANE ALIGNMENT ROD .....	18301



**R. M. YOUNG COMPANY**  
2801 Aero Park Drive  
Traverse City, Michigan 49686 USA  
TEL: (231) 946-3980 FAX: (231) 946-4772  
E-mail: met.sales@youngusa.com  
Web Site: www.youngusa.com