



Sea-Bird Electronics, Inc.
 13431 NE 20th Street
 Bellevue, WA 98005
 USA

Phone: (425) 643-9866
 Fax: (425) 643-9954
 E-mail: seabird@seabird.com
 Web: www.seabird.com

APPLICATION NOTE NO. 40

Revised September 2011

SBE 5T and 5P PUMP SPEED ADJUSTMENT

Equipment: DC power supply
 Frequency counter

Drawings: 31441B (schematic)
 41250A (assembly)

The pump housing must be disassembled to adjust the pump speed. SBE 5P and 5T electronics are the same, but separate instructions for removing / reinstalling the electronics are provided for each pump, because of differences in mechanical details.

Note: **In September 2011, Sea-Bird changed the SBE 5T mechanical design;** the new design is easily differentiated from the old design because the new design does not have a retaining ring (see photo below). The old SBE 5T is opened from the end with the retaining ring and bulkhead connector; the new SBE 5T is opened from the end with the pump head. Instructions for disassembly/reassembly of the new SBE 5T pump are identical to those for the SBE 5P pump.

1. Remove the electronics from the housing:

- **SBE 5T Titanium Pump with retaining ring (old design, discontinued September 2011) –**

- A. Unscrew the white plastic end cap retainer ring.
- B. Install a 2-pin dummy plug with locking sleeve over the bulkhead connector to provide a good grip and protect the connector pins. Rotate the end cap back and forth while carefully pulling the end cap away from the housing. Pull the end cap and attached electronics out of the housing.

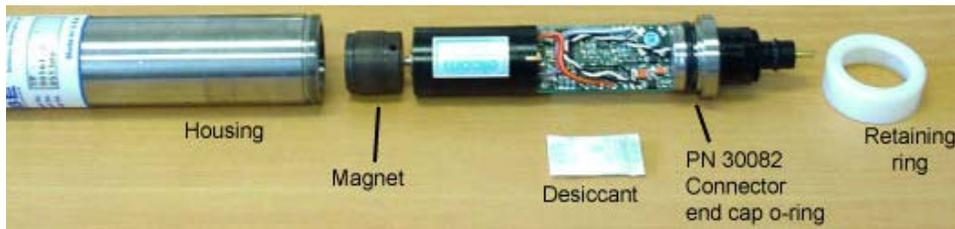

Retaining ring (only present on old SBE 5T)

SBE 5T (old design, discontinued September 2011)

- **SBE 5P Plastic Pump and SBE 5T Titanium Pump without retaining ring (new design, September 2011) -**

- A. Unscrew the pump head from the housing.
- B. Pull out the end cap from the housing.
- C. Pull out the electronics from the housing. Note that the electronics are wired to the bulkhead connector inside the housing.

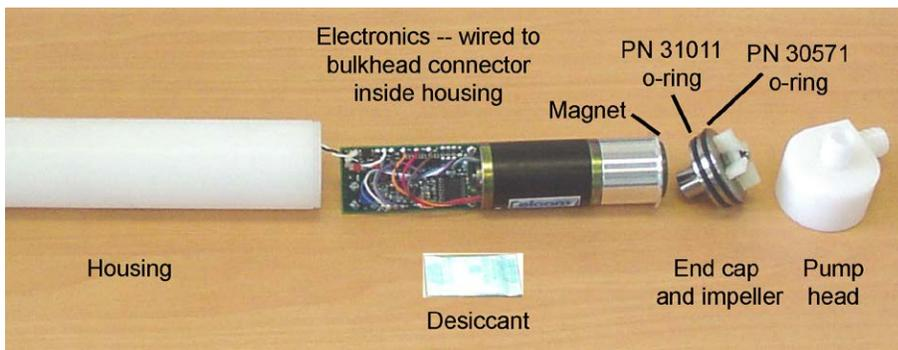

SBE 5T (new design, September 2011)

SBE 5P

2. Connect the positive lead of your frequency counter to the yellow test post (T1) (drawing 41250A). Connect the frequency counter ground (negative) to the power supply ground (negative).

3. Supply power:

- **Low voltage pump** (pump with LV in the serial number) - Supply 6 volts DC power to the bulkhead connector or directly to the PCB (P8 is positive, P19 or P18 is common, drawing 41250A).
- **Normal voltage pump** - Supply 12 volts to the bulkhead connector or directly to the PCB (P8 is positive, P19 or P18 is common, drawing 41250A).

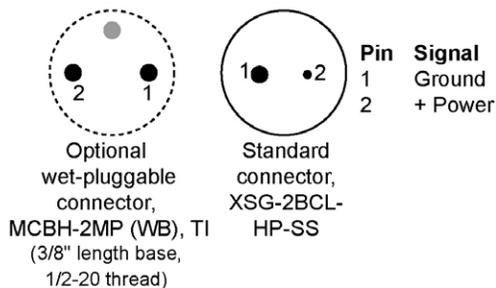

4. A 2K ohm potentiometer (R11, drawing 41250A) is located on the back side of the board. Adjust the potentiometer to obtain the frequency corresponding to the desired speed (Frequency * 30 = rpm):

- Pittman **18.2Ω motor** (P/N 3711B113-R1) - Set jumper position P15 to P17 (1300 rpm) and P12 to P13 (1300 rpm), and adjust the speed as desired, up to the nominal maximum of 2000 rpm.
- Pittman **7.4Ω motor** (P/N 3711B112-R1) - Set jumper position P15 to P16 (3000 rpm) and P14 to P13 (3000 rpm), and adjust the speed as desired, up to the nominal maximum of 4500 rpm. To adjust speed below approximately 2200 rpm, set jumper position P15 to P17 (1300 rpm) and P12 to P13 (1300 rpm), and adjust speed using the potentiometer.
- Pittman **3.55Ω motor** (P/N 3711B112-R2) - Set jumper position P15 to P16 (3000 rpm) and P14 to P13 (3000 rpm), and adjust the speed as desired, up to the nominal maximum of 4500 rpm. To adjust speed below approximately 2200 rpm, set jumper position P15 to P17 (1300 rpm) and P12 to P13 (1300 rpm), and adjust speed using the potentiometer.

5. Disconnect the frequency counter and the power supply.

6. Reinstall the electronics in the housing:

- **SBE 5T Titanium Pump with retaining ring (old design, discontinued September 2011) –**
 - A. Inspect the connector end cap o-ring and the mating surface in the housing for dirt, nicks, and cuts. Clean as necessary. If the o-ring or mating surface is damaged, return the pump to Sea-Bird for repairs.
Note: Sea-Bird recommends that connector end cap o-ring replacement be performed at the factory, because the pump's physical configuration makes customer-replacement of this o-ring difficult to perform without special tools.
 - B. Apply a light coat of o-ring lubricant (Parker Super O Lube) to the o-ring and mating surfaces. Gently place a **new desiccant bag** (PN 30558 – 1 gram) on the electronics (see Application Note 71 for desiccant use and regeneration). Reinstall the electronics in the housing, until the o-ring has fully seated. Reinstall the retaining ring on the connector end cap.
- **SBE 5P Plastic Pump and SBE 5T Titanium Pump without retaining ring (new design, September 2011) -**
 - A. Inspect the connector end cap o-ring and the mating surface in the housing for dirt, nicks, and cuts. Clean and/or replace o-rings as necessary.
 - B. Apply a light coat of o-ring lubricant (Parker Super O Lube) to the o-ring and mating surfaces. Gently place a **new desiccant bag** (PN 30558 – 1 gram) on the electronics (see *Application Note 71* for desiccant use and regeneration). Reinstall the electronics in the housing. Reinstall the end cap in the housing, carefully aligning the end cap with the housing and pushing hard on the end cap to seat the first o-ring in the housing (only 1 o-ring should now be visible). **CAUTION: If you are not careful, you may pinch the o-ring which may allow water to enter the housing, damaging the electronics.**
 - C. Reinstall the pump head on the end cap.

DATE	BY	REVISION	REASON	DATE	BY	CHK
05/15/97	A	R3 WAS SHOWN AS 52K		15289	UG	
08/30/99	B	ECN642 - R17/R2 PIN, C4 WAS 83UF				

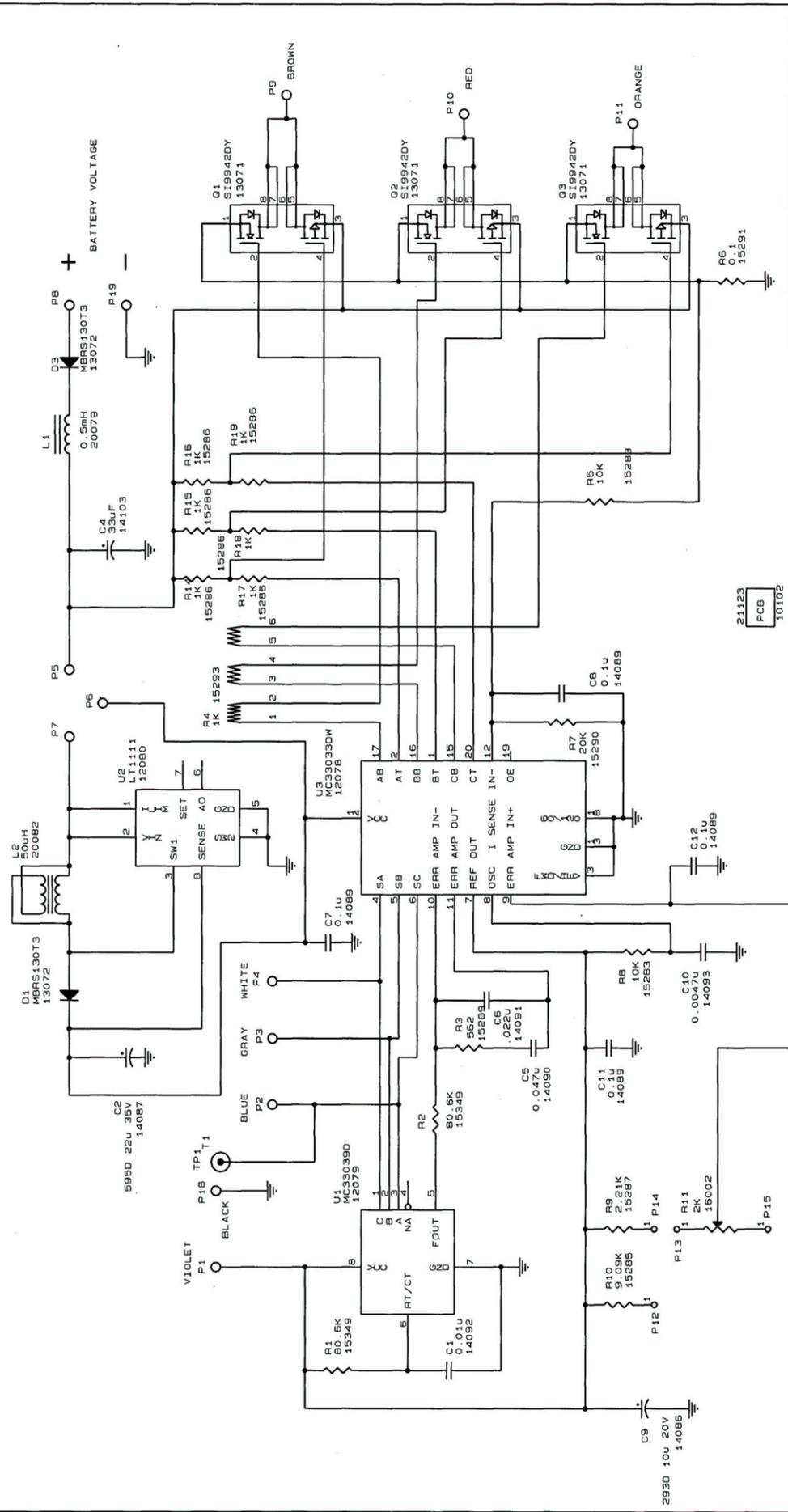

SEA-BIRD ELECTRONICS, INC.	
Title	ASSEMBLY 40605_80639
Size	PUMP DRIVER, SMT, PITTMAN MOTOR
REV	Document Number 31441
B	
REV	
B	
DATE	AUGUST 30, 1998 Street 1 of 1

21123
PCB
10102

JUMPER P12 TO P13 AND P17 TO P15 FOR 1300 RPM
JUMPER P14 TO P13 AND P16 TO P15 FOR 3000 RPM

DATE	SYM	REVISION RECORD	AUTH.	DR.	CK.
4/05	A	ADD 801572. * ASSY	CB	CE	

SLB PRINTED ON 10.10.20 13 APR 2005
 PART NUMBER..... DESCRIPTION..... DPA

- 806575 SBE ST #3V0G MOTOR/DRIVER, 7.4 OHM
- 20081 MOTOR, PUMP, 7.4 OHM
- 23595 PITTMAN 3711B1P-R1
- 30235 BLOCK /TNG 20624B
- 30235 WASHER, WN-2, #2 NYLON
- 30257 MACH SCREW, 2-56 X 1/4
- 30560 PH, SS
- 30560 MACH SCREW, 2-56 X 9/16
- 80639 PUMP DRIVER, SURFACE MOUNT /TNG 40650C

 SLB PRINTED ON 10.10.21. 13 APR 2005
 PART NUMBER..... DESCRIPTION..... DPA

- 80676 SBE ST #3V0G MOTOR/DRIVER, 18.02 OHM
- 20080 MOTOR, PUMP, 18.02 OHM
- 23595 PITTMAN 3711B1P-R1
- 30235 BLOCK /TNG 20624B
- 30235 WASHER, WN-2, #2 NYLON
- 30257 MACH SCREW, 2-56 X 1/4
- 30560 PH, SS
- 30560 MACH SCREW, 2-56 X 9/16
- 80639 PUMP DRIVER, SURFACE MOUNT /TNG 40650C

 PART NUMBER..... DESCRIPTION..... DPA

- 801572 SBE ST #3V0G MOTOR/DRIVER, 3.55 OHM
- 20176 MOTOR, PUMP, 3.55 OHM
- 23595 PITTMAN 3711B1P-R1
- 30235 BLOCK /TNG 20624B
- 30235 WASHER, WN-2, #2 NYLON
- 30257 MACH SCREW, 2-56 X 1/4
- 30560 PH, SS
- 30560 MACH SCREW, 2-56 X 9/16
- 80639 PUMP DRIVER, SURFACE MOUNT /TNG 40650C

FINISH GENERIC ASSEMBLY TO SPECIFIC ASSEMBLY BY INSTALLING VOLTAGE AND SPEED JUMPERS AS SHOWN ON THE CHART

SEA-BIRD ELECTRONICS, INC	
PART NO. VARIOUS (B) SCALE	DRWN BY DG
SCHEM 31441B (P. SCALE 0.90)	APPR BY
TITLE	
SBE ST MOTOR/DRIVER ASSEMBLY	
DATE 2/13/03	REV A
TNG NO. 41250	

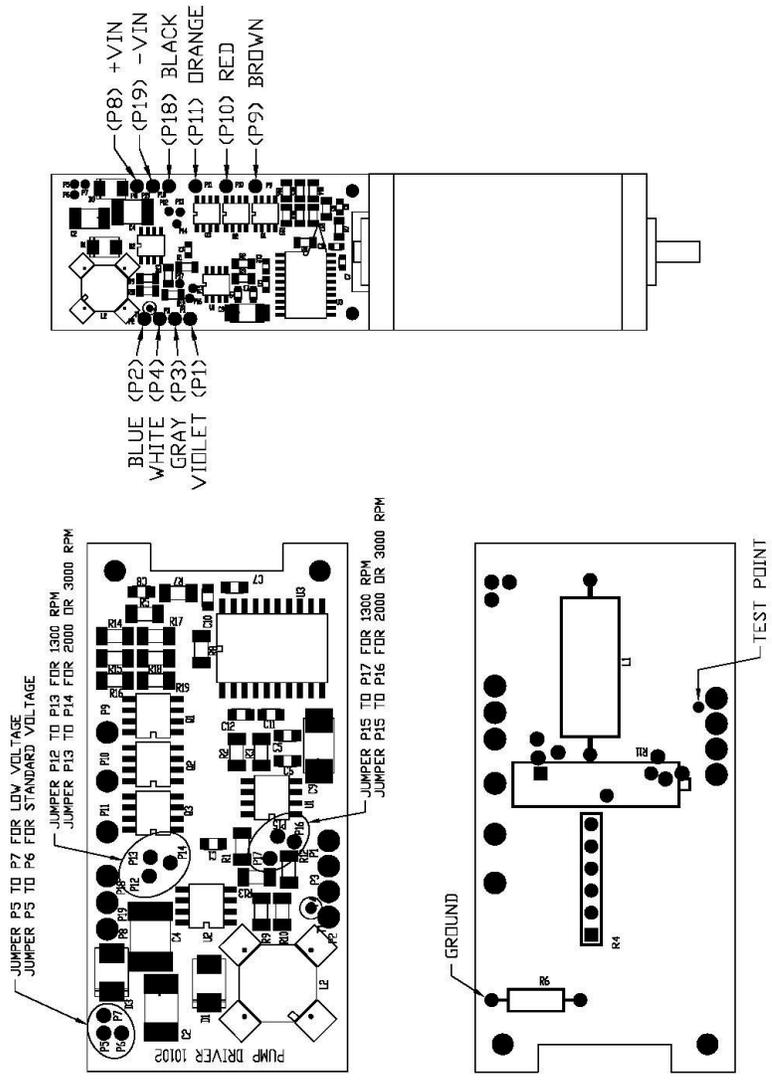

SBE PN	DESCRIPTION	VOLTAGE	SPEED	SPEED
80575.2	#3 WINDING (7.4 OHM), STANDARD VOLTAGE, 2000 RPM	P5-P6	P13-P14	P15-P16
80575.2LV	#3 WINDING (7.4 OHM), LOW VOLTAGE, 2000 RPM	P5-P7	P13-P14	P15-P16
80575.3	#3 WINDING (7.4 OHM), STANDARD VOLTAGE, 3000 RPM	P5-P6	P13-P14	P15-P16
80576.1	#5 WINDING (18.02 OHM), STANDARD VOLTAGE, 1300 RPM	P5-P6	P12-P13	P15-P17
80576.1LV	#5 WINDING (18.02 OHM), LOW VOLTAGE, 1300 RPM	P5-P7	P12-P13	P15-P17
80576.2	#5 WINDING (18.02 OHM), STANDARD VOLTAGE, 2000 RPM	P5-P6	P13-P14	P15-P16
80576.2LV	#5 WINDING (18.02 OHM), LOW VOLTAGE, 2000 RPM	P5-P7	P13-P14	P15-P16
801572.2	#3 WINDING (3.55 OHM), STANDARD VOLTAGE, 2000 RPM	P5-P6	P13-P14	P15-P16
801572.2LV	#3 WINDING (3.55 OHM), LOW VOLTAGE, 2000 RPM	P5-P7	P13-P14	P15-P16
801572.3	#3 WINDING (3.55 OHM), STANDARD VOLTAGE, 3000 RPM	P5-P6	P13-P14	P15-P16

Application Note Revision History

Date	Description
April 1999	Initial release
November 2002	Add information about jumper P12 to P13 (1300 rpm) and P14 to P13 (3000 rpm)
May 2005	New drawing numbers and motor
June 2007	Update to include instructions for 5P as well as 5T Add photos to clarify instructions Add standard and wet-pluggable connector diagram to clarify pinouts
September 2011	Add information on new mechanical design for SBE 5T