



SEA-BIRD
SCIENTIFIC

User Manual

Release Date: 02/12/2015

SBE Sea-Bird
Electronics

SBE 38 Digital Oceanographic Thermometer

With RS-232 or RS-485 Interface



Manual version
Firmware version

- 015
- 1.4 & later



Sea-Bird Electronics
13431 NE 20th Street
Bellevue, Washington
98005 USA

Tel: +1 425-643-9866
seabird@seabird.com
www.seabird.com

Limited Liability Statement

Extreme care should be exercised when using or servicing this equipment. It should be used or serviced only by personnel with knowledge of and training in the use and maintenance of oceanographic electronic equipment.

SEA-BIRD ELECTRONICS, INC. disclaims all product liability risks arising from the use or servicing of this system. SEA-BIRD ELECTRONICS, INC. has no way of controlling the use of this equipment or of choosing the personnel to operate it, and therefore cannot take steps to comply with laws pertaining to product liability, including laws which impose a duty to warn the user of any dangers involved in operating this equipment. Therefore, acceptance of this system by the customer shall be conclusively deemed to include a covenant by the customer to defend, indemnify, and hold SEA-BIRD ELECTRONICS, INC. harmless from all product liability claims arising from the use or servicing of this system.

Declaration of Conformity

Sea-Bird Electronics, Inc.
 13431 NE 20th Street, Bellevue, WA 98005 USA

DECLARATION OF CONFORMITY

Manufacturer's Name: Sea-Bird Electronics
Manufacturer's Address: 13431 NE 20th Street
 Bellevue, WA 98005, USA

The Authorized Representative located within the Community is:
 OTT MESSTECHNIK GmbH & Co.KG
 P.O.Box: 2140 / 87411 Kempten / Germany
 Ludwigstrasse 16 / 87437 Kempten
 Internet: <http://www.ott.com>
 Phone: +49 831 5617 – 100
 Fax: +49 831 5617 - 209

Device Description: Various Data Acquisition Devices and Sensors

Model Numbers:

3S	3F	3plus	4C	4M	5T	5P	5M	7
8	9plus	11plus	14	16plus V2	16plus-IM V2		17plus V2	18
19plus V2	21	25plus	26plus	27	29	32	32C	32SC
33	35	35RT	36	37-IMP	37-IM	37-SMP	37-SM	37-SIP
37-SI	38	39	39-IM	39plus	41	41CP	43	43F
44	45	49	50	52-MP	53BPR	54	55	56
63	SIM	ICC	IMM	PDIM	AFM	90488	90204	90402
90504	Glider Payload CTD		NiMH Battery Charger and Battery Pack					

Applicable EU Directives: Machinery Directive 98 / 37 /EC
 EMC Directive 2004 / 108 /EC
 Low Voltage Directive (73 / 23 /EEC) as amended by (93 / 68 /EEC)

Applicable Harmonized Standards:
 EN 61326-1:2006 Class A Electrical Equipment for Measurement, Control, and Laboratory Use, EMC Requirement – Part 1: General Requirements
 (EN 55011:2007 Group 1, Class A)

 EN 61010-1:2001, Safety Requirements for Electrical Equipments for Measurement, Control, and Laboratory Use – Part 1: General Requirements

Declaration based upon compliance to the Essential Requirements and Letter of Opinion from CKC Certification Services, LLC., Notified Body 0976

I, the undersigned, hereby declare that the equipment specified above conforms to the above European Union Directives and Standards.

Authorized Signature: 
 Name: Nordeen Larson
 Title of Signatory: President
 Date: 3 September 2013
 Place: Bellevue, WA

Table of Contents

Limited Liability Statement	2
Declaration of Conformity	3
Table of Contents	4
Section 1: Introduction	5
About this Manual	5
Quick Start	5
Unpacking SBE 38.....	6
Section 2: Description of SBE 38	7
System Description	7
Specifications.....	8
Dimensions and End Cap Connector	9
Cables and Wiring	9
Section 3: Preparing SBE 38 for Deployment	10
Installing Software.....	10
Power and Communications Test	10
Section 4: Deploying and Operating RS-232 SBE 38	14
Sampling Modes	14
Polled Sampling.....	14
Continuous Sampling.....	15
Baud Rate, Cable Length, and Power	16
Command Descriptions.....	18
Data Formats.....	20
Deployment.....	20
Recovery	21
Section 5: Routine Maintenance and Calibration	22
Corrosion Precautions.....	22
Connector Mating and Maintenance	22
O-Ring Maintenance.....	22
Sensor Calibration.....	23
Glossary	24
Appendix I: Functional Description	25
Sensor Interface	25
Settings	25
Appendix II: Electronics Disassembly/Reassembly	26
Appendix III: RS-485 Interface	27
Operation Description.....	27
Command Descriptions.....	28
Data Formats.....	29
Wiring.....	30
Conversion of RS-232 to RS-485 or RS-485 to RS-232.....	30
Appendix IV: RS-232 Command Summary	31
Appendix V: Replacement Parts	32
Appendix VI: Manual Revision History	33
Index	34

Section 1: Introduction

This section includes a Quick Start procedure, and photos of a typical SBE 38 shipment.

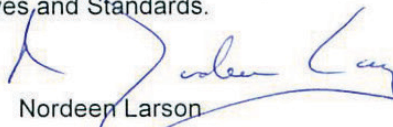
About this Manual

This manual is to be used with the SBE 38 Digital Oceanographic Thermometer. It is organized to guide the user from installation through operation and data collection. We've included detailed specifications, command descriptions, maintenance and calibration information, and helpful notes throughout the manual.

Sea-Bird welcomes suggestions for new features and enhancements of our products and/or documentation. Please contact us with any comments or suggestions (seabird@seabird.com or 425-643-9866). Our business hours are Monday through Friday, 0800 to 1700 Pacific Standard Time (1600 to 0100 Universal Time) in winter and 0800 to 1700 Pacific Daylight Time (1500 to 0000 Universal Time) the rest of the year.

Quick Start

Follow these steps to get a Quick Start using the SBE 38 with an **RS-232 interface**. The manual provides step-by-step details for performing each task:

1. Test Power and Communications (see *Section 3: Preparing SBE 38 for Deployment*).
2. Deploy the SBE 38 (see *Section 4: Deploying and Operating RS-232 SBE 38* for a complete description of setup, or see *Appendix IV: RS-232 Command Summary*):
 - A. Establish setup parameters.
 - B. Check status (**DS**) and calibration coefficients (**DC**) to verify setup.
 - C. Use **one** of the following sequences to start sampling:
 - If **AutoRun=N**: Send **Go** to start sampling continuously now, or **TS** or **TH** to take a single sample.
 - If **AutoRun=Y**: Apply power to start sampling continuously now.
 - D. Deploy SBE 38.

For an SBE 38 with **RS-485 interface**, see *Appendix III: RS-485 Interface*.

Unpacking SBE 38

Shown below is a typical SBE 38 shipment.



SBE 38



I/O Cable with 9V battery snap connector and 9V battery



Software, and Electronic Copies of Software Manuals and User Manual

Section 2: Description of SBE 38

This section describes the functions and features of the SBE 38, including specifications and dimensions.

System Description



Sophisticated A/D acquisition electronics, ultra-stable thermistor, and state-of-the-art calibration provide the standards-level performance of an expensive AC bridge and platinum thermometer at a small fraction of the cost. The SBE 38 is unaffected by shock and vibration, has high accuracy and stability, and is easy to use. It has a rugged, corrosion-proof, 10,500 meter (34,400 foot) titanium pressure housing. Real-time temperature data is transmitted in ASCII characters (in °C or raw counts) via an RS-232 or RS-485 serial interface for display or logging by PC or data logger.

The SBE 38's measurement range is -5 to +35 °C. Absolute accuracy is better than ± 0.001 °C (1 mK) and resolution is approximately 0.00025 °C (0.25 mK). Each sensor includes certification that demonstrates drift of less than 0.001 °C (1 mK) during a six-month period.

Applications include calibration baths, oceanographic/aquatic research, and environmental monitoring.

The SBE 38 operates in one of three ways:

- RS-232 (full duplex) with one SBE 38 connected to the interface
- RS-485 (half duplex) with one SBE 38 connected to the interface
- RS-485 (half duplex) with several RS-485 sensors sharing one pair of wires

On power-up, the SBE 38 reads its EEPROM, which includes calibration coefficients and other setup information. As programmed, the SBE 38 samples and transmits temperature continuously, or waits for a command to begin sampling. Note that for RS-485 applications with several sensors sharing one pair of wires, the SBE 38 cannot sample continuously.

The SBE 38 is frequently integrated as a remote temperature sensor with one of our thermosalinographs (SBE 21 Thermosalinograph or SBE 45 MicroTSG), to provide accurate sea surface temperature. See the manuals for those instruments for integration information.

Notes:

- Help files provide detailed information on the software.
- Separate software manuals on CD-ROM contain detailed information on Seasave V7 and SBE Data Processing.
- Sea-Bird supplies the current version of our software when you purchase an instrument. As software revisions occur, we post the revised software on our website. See our website for the latest software version number, a description of the software changes, and instructions for downloading the software.

The SBE 38 is supplied with a powerful Windows software package, Seasoft V2, which includes:

- **Seaterm** terminal program for easy communication.
- **Seasave V7** real-time data acquisition and **SBE Data Processing** post-processing programs –Seasave V7 and SBE Data Processing can be used to view and process the entire data stream, including data from the SBE 38, when the SBE 38 is integrated with one of the following -
 - SBE 21 or 45 thermosalinograph;
 - SBE 16*plus*, 16*plus* V2, or 16*plus*-IM V2 SeaCAT C-T Recorder; or SBE 19*plus* V2 SeaCAT CTD Profiler.
 - SBE 25*plus* Sealogger CTD (SBE 38 data cannot be viewed in real-time with this CTD)

Specifications

Measurement Range	-5 to +35 °C	
Initial Accuracy ¹	± 0.001 °C (1 mK)	
Typical Stability	0.001 °C (1 mK) in 6 months, certified	
Resolution	0.00025 °C (0.25 mK)	
Calibration	-1 to +32 °C	
Response Time ²	500 milliseconds	
Self-Heating Error	less than 200 µK	
RMS Noise (at temperature equivalent of 8.5 °C)	NAvg	Noise (°C)
	1	0.000673
	2	0.000408
	4	0.000191
	8	0.000133
	16	0.000081
	32	0.000052
	<i>Note:</i> NAvg = number of A/D cycles per sample. Interval between samples (seconds) = (0.133 * NAvg) + 0.339	
External Power	<i>RS-232:</i> 8 – 15 VDC at 15 milliamps average <i>RS-485 half-duplex:</i> 8 – 15 VDC at 10 milliamps average	
Materials	Titanium pressure case rated at 10,500 meters (34,400 feet)	
Weight	In water: 0.5 kg (1.2 lbs) In air: 0.9 kg (2.0 lbs)	

Note:

If the SBE 38 is sampling data and the voltage is less than 6.5 volts for 10 consecutive scans, the SBE 38 halts sampling and displays a low battery indication in the data.

Notes:

¹ NIST-traceable calibration applying over the entire range.

² Time to reach 63% of final value following a step change in temperature.

Dimensions and End Cap Connector

Pin	Signal
1	Common
2	RS-232 Receive or RS-485A
3	RS-232 Transmit or RS-485B
4	Power

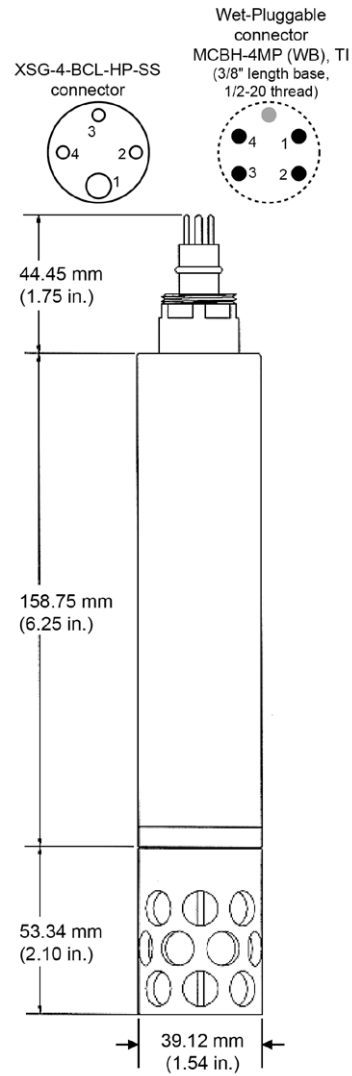

Cables and Wiring

4-pin to DB9 - SBE 38 to computer
 (Note: also available with battery snap; see DN 32604 [RMG connector] and 32490 [MCIL connector])

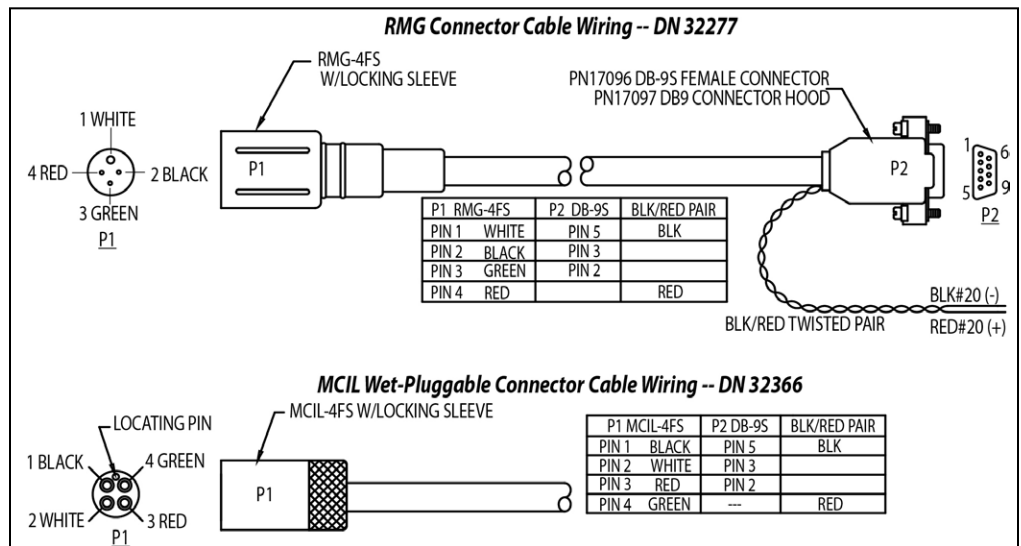

Section 3:

Preparing SBE 38 for Deployment

This section describes the software installation and the pre-check procedure for preparing the SBE 38 for deployment.

Installing Software

Notes:

- Help files provide detailed information on the software. Separate software manuals on the CD-ROM contain detailed information on Seasave V7 and SBE Data Processing.
- It is possible to use the SBE 38 without the Seaterm terminal program by sending direct commands from a dumb terminal or terminal emulator, such as Windows HyperTerminal.
- Sea-Bird supplies the current version of our software when you purchase an instrument. As software revisions occur, we post the revised software on our website. See our website for the latest software version number, a description of the software changes, and instructions for downloading the software.

Seasoft V2 was designed to work with a PC running Windows XP service pack 2 or later, Windows Vista, or Windows 7 (32-bit or 64-bit).

If not already installed, install Sea-Bird software programs on your computer using the supplied software CD:

1. Insert the CD in your CD drive.
2. Install software: Double click on **SeasoftV2.exe**. Follow the dialog box directions to install the software. The installation program allows you to install the desired components. Install all the components, or just install Seaterm, Seasave V7, and SBE Data Processing

The default location for the software is c:\Program Files\Sea-Bird. Within that folder is a sub-directory for each program.

Power and Communications Test

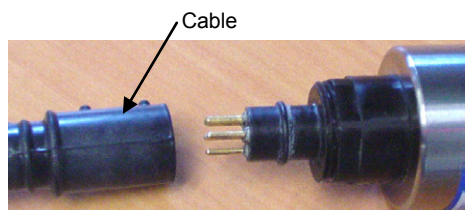
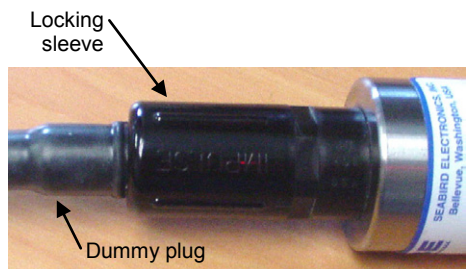

Test Setup

1. If applicable, remove locking sleeve and dummy plug from bulkhead connector:
 - A. By hand, unscrew the locking sleeve from the SBE 38's bulkhead connector. **If you must use a wrench or pliers, be careful not to loosen the bulkhead connector instead of the locking sleeve.**
 - B. Remove the dummy plug from the SBE 38's bulkhead connector by pulling the plug firmly away from the connector.
2. Install the Sea-Bird I/O cable on the SBE 38:
 - **XSG Connector** (shown in photos) - Align the raised bump on the side of the connector with the large pin (pin 1 - ground) on the SBE 38.
 - **MCBH Connector** – Align the pins.
3. Connect the I/O cable connector to your computer's serial port.
4. Connect the I/O cable battery terminal clip to a 9-volt battery. Note that the 9-volt battery supplied with the SBE 38 will provide approximately 50 hours of operation.

Test

Note:
See SEeaterm's help files.

1. Double click on Seaterm.exe. If this is the first time the program is used, the setup dialog box may appear:



Select the instrument type (SBE 38) and the computer COM port for communication with the SBE 38. Click OK.

2. The main screen looks like this:

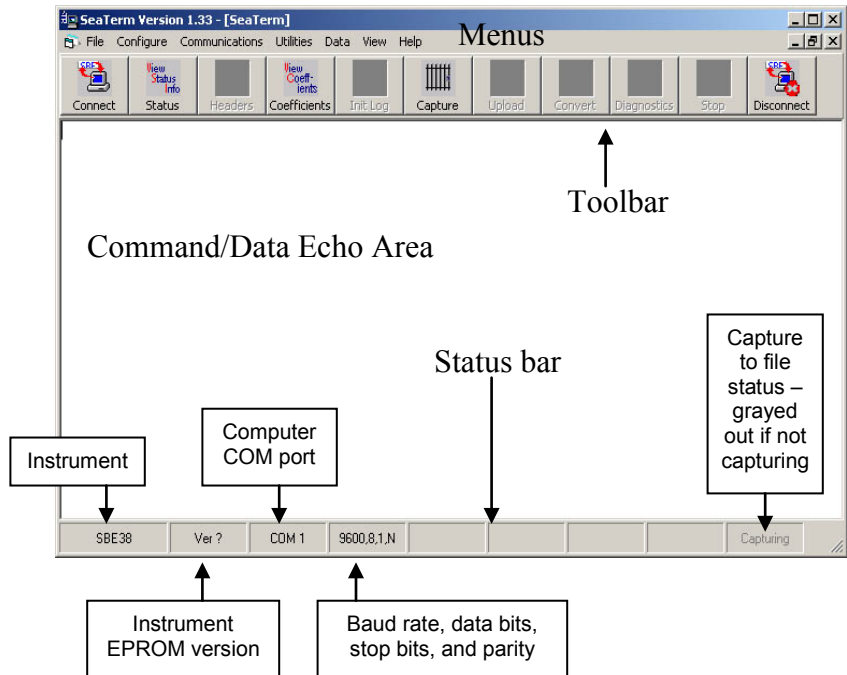

Note:
There is at least one way, and as many as three ways, to enter a command:

- Manually type a command in Command/Data Echo Area
- Use a menu to automatically generate a command
- Use a Toolbar button to automatically generate a command

Note:
Once the system is configured and connected (Steps 3 through 5 below), to update the Status bar:

- on the Toolbar, click Status; or
- from the Utilities menu, select Instrument Status.

Seaterm sends the status command, which displays in the Command/Data Echo Area, and updates the Status bar.

- **Menus** – Contains tasks and frequently executed instrument commands.
- **Toolbar** – Contains buttons for frequently executed tasks and instrument commands. All tasks and commands accessed through the Toolbar are also available in the Menus. To display or hide the Toolbar, select View Toolbar in the View menu. Grayed out Toolbar buttons are not applicable.
- **Command/Data Echo Area** – Echoes a command executed using a Menu or Toolbar button, as well as the instrument's response. Additionally, a command can be manually typed in this area, from the available commands for the instrument. Note that the instrument must be *awake* for it to respond to a command (use Connect on the Toolbar to wake up the instrument).
- **Status bar** – Provides status information. To display or hide the Status bar, select View Status bar in the View menu.

Following are the Toolbar buttons applicable to the SBE 38:

Toolbar Button	Description	Equivalent Command*
Connect	Re-establish communications with SBE 38. Computer responds with S> prompt.	(press Enter key)
Status	Display instrument setup and status (number of A/D cycles per sample, sampling status, etc.).	DS
Coefficients	Display calibration coefficients.	DC
Capture	Capture instrument responses on screen to file. File has .cap extension. Press Capture again to turn off capture. Capture status displays in Status bar.	—
Disconnect	Free computer COM port used to communicate with SBE 38. COM port can then be used by another program.	—

*See *Command Descriptions* in *Section 4: Deploying and Operating RS-232 SBE 38*.

- In the Configure menu, select SBE 38. The dialog box looks like this:

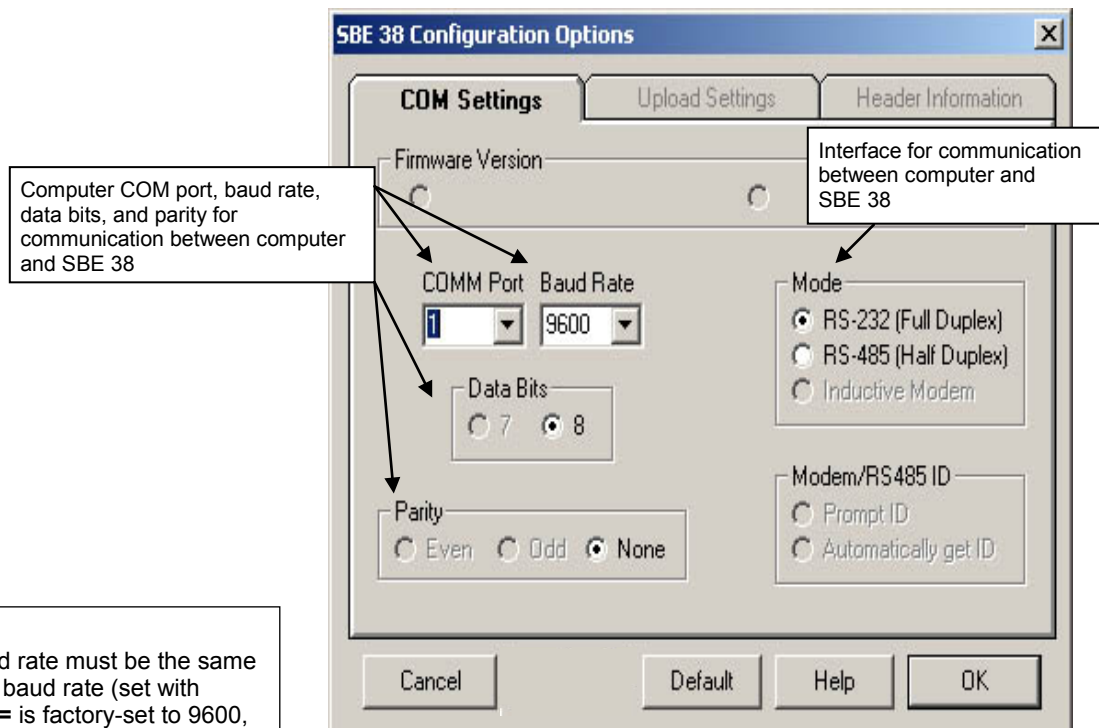

Notes:

- Seaterm's baud rate must be the same as the SBE 38 baud rate (set with **Baud=**). **Baud=** is factory-set to 9600, but can be changed by the user (see *Command Descriptions* in *Section 4: Deploying and Operating RS-232 SBE 38*).
- When you click OK, Seaterm saves the Configuration Options settings to the SeaTerm.ini file in your Windows directory. SeaTerm.ini contains the last saved settings for **each** instrument. When you open Seaterm and select the desired instrument (SBE 38, 39, etc.) in the Configure menu, the Configuration Options dialog box shows the last saved settings for that instrument.

Make the selections in the Configuration Options dialog box:

- COMM Port:** COM 1 through COM 10, as applicable
 - Baud Rate:** 9600 (documented on Configuration Sheet)
 - Data Bits:** 8
 - Parity:** None
 - Mode:** RS-232 (Full Duplex) or RS-485 (Half Duplex)
- Click OK to save the settings.

4. In the Communications menu, select *Options / Cycle baud when connecting*.
5. Click Connect on the Toolbar. Seaterm tries to connect to the SBE 38 at the baud set in Step 3. If it cannot, it cycles through all other possible baud rates to try to connect. When it connects, the display looks like this:

```
SBE 38  V 1.4  S/N 0090    (this line may not appear)
S>
```

This shows that correct communications between the computer and the SBE 38 has been established.

If the system does not provide the S> prompt:

- Click Connect again.
- Verify the correct instrument was selected in the Configure menu and the settings were entered correctly in the Configuration Options dialog box. Note that the baud rate's factory setting is documented on the Configuration Sheet in this manual.
- Check cabling between the computer and the SBE 38.

6. Display SBE 38 status information by clicking Status on the Toolbar. The display looks like this:

```
SBE 38  V 1.4  S/N = 0090
NAVG=1
Not sampling data
Automatically start sampling on power up
Default interface is RS-232
```

7. Command the SBE 38 to take a sample by typing **TS** and pressing the Enter key. The display looks like this if the output format was set to converted data (**Format=C**) with 4 digits to the right of the decimal place (**Digits=4**):

```
23.7658
```

where 23.7658 = temperature in degrees Celsius
This number should be reasonable; i.e., room temperature.

The SBE 38 is ready for programming and deployment.

Note:

See *Appendix III: RS-485 Interface* for details on sending commands to an SBE 38 with RS-485 interface.

Section 4:

Deploying and Operating RS-232 SBE 38

Note:

See *Appendix III: RS-485 Interface* for details on deploying and operating an SBE 38 with RS-485 interface.

This section includes:

- system operation description, including example sets of operation commands
- baud rate, cable length, and power limitations
- detailed command descriptions
- data formats
- instructions for deploying and recovering the SBE 38

Sampling Modes

The SBE 38 has two sampling modes:

- Polled Sampling – take a single sample on command
- Continuous Sampling – sample continuously; start when power is applied or on command, depending on the setup

Descriptions and examples follow for an SBE 38 with **RS-232 Interface**. Note that the SBE 38's response to each command is not shown in the examples. Review the sampling modes and the commands described in *Command Descriptions* before setting up your system.

Polled Sampling

The SBE 38 takes one sample of data on command. Transmission of data to the computer is dependent on the particular command used.

Example: (user input in bold)

Apply power and establish communications. Set up to average 4 measurements per sample and output converted data with 3 digits after decimal place. Command SBE 38 to take a sample and send data to computer.

(Apply power and then click Connect on Toolbar.)

S>**NAVG=4**

S>**FORMAT=C**

S>**DIGITS=3**

S>**DS** (to verify setup)

S>**TS**

Continuous Sampling

The SBE 38 continuously samples and transmits real-time data.

Sampling is started by:

- Sending **Go**, or
- Setting **AutoRun=Y**. If **AutoRun=Y**, sampling automatically starts when power is applied.

Sampling is stopped by:

- Sending **Stop**, or
- Removing power.

Example: Continuous Sampling (user input in bold)

Example 1 AutoRun=N: Apply power and establish communications. Set up to average 4 measurements per sample and output converted data with 3 digits after decimal place. Set up to wait for a command when power is applied. Remove power.

(Apply power and then click Connect on Toolbar.)

S>**NAV**=4

S>**FORMAT**=C

S>**DIGITS**=3

S>**AUTORUN**=N

S>**DS** (to verify setup)

(Remove power.)

When ready to start sampling, apply power and establish communications. Send command to start sampling continuously, outputting real-time data. When desired, send command to stop sampling.

(Apply power and then click Connect on Toolbar.)

S>**GO**

S>**STOP** (You may need to send **Stop** several times to interrupt sampling.)

Example 2 AutoRun=Y: Apply power and establish communication. Set up to average 4 measurements per sample and output converted data with 3 digits after decimal place. Set up to automatically begin sampling when power is applied. Remove power.

(Apply power and then click Connect on Toolbar.)

S>**NAV**=4

S>**FORMAT**=C

S>**DIGITS**=3

S>**AUTORUN**=Y

S>**DS** (to verify setup)

(Remove power.)

To start sampling, apply power. SBE 38 begins sampling continuously, outputting real-time data.

To stop sampling, remove power.

To change setup: apply power, and then stop sampling by command.

(Apply power)

(Press Enter key to get S> prompt)

S>**STOP** (You may need to send **Stop** several times to interrupt sampling.)

(Enter commands as desired to change setup.)

Baud Rate, Cable Length, and Power

On the ship, cables longer than 3 meters should be installed inside an earthed metal conduit by a qualified electrician. This minimizes the potential for external signals to disrupt communication and ensures that high voltage lines (such as the sea cable) are sufficiently protected. Cables shorter than 3 meters can be used without shielding when installing or bench testing the instrument.

Notes:

- Baud rate is set with **Baud=** (see *Command Descriptions* in this section).
- For RS-485, see *Appendix III: RS-485 Interface* for baud rate limitations.

Baud Rate and Cable Length

For **RS-232**, the length of cable that the SBE 38 can drive to transmit real-time data is dependent on the baud rate. The allowable combinations are:

Maximum Cable Length (meters)	Maximum Baud Rate
800	1200
400	2400
200	4800
100	9600

Note:

Common wire resistances:

Gauge	Resistance (ohms/foot)
12	0.0016
14	0.0025
16	0.0040
18	0.0064
19	0.0081
20	0.0107
22	0.0162
24	0.0257
26	0.0410
28	0.0653

Power and Cable Length

There are two issues to consider:

- Limiting the communication IR loss to 1 volt if transmitting real-time data via RS-232; higher IR loss will cause the instrument to transmit data that does not meet the RS-232 communication standard.
- Supplying enough power at the power source so that sufficient power is available at the instrument after considering IR loss.

Looking at each issue separately:

Limiting IR Loss to 1 Volt

The limit to cable length is typically reached when the maximum *communication* current times the power common wire resistance is more than 1 volt.

$$V_{\text{limit}} = 1 \text{ volt} = IR_{\text{limit}}$$

Where

I = current required by SBE 38 (15 mA for RS-232; 10 mA for RS-485).

Maximum cable length = $R_{\text{limit}} / \text{wire resistance per foot}$

Example 1 – For 18 gauge wire, what is maximum distance to transmit power to RS-232 SBE 38? Is this controlling factor for maximum cable length if wanting to transmit at 1200 baud?

$$R_{\text{limit}} = V_{\text{limit}} / I = 1 \text{ volt} / 0.015 \text{ Amps} = 67 \text{ ohms}$$

For 18 gauge wire, resistance is 0.0064 ohms/foot.

Therefore, maximum cable length is 67 ohms / 0.0064 ohms/foot = 10417 feet = 3176 meters.

Note that 3176 meters > 800 meters (maximum distance SBE 38 can transmit data at 1200 baud), so IR loss is not controlling factor for this example.

Example 2 – Same as above, but there are 4 SBE 38s powered from the same power supply.

$$R_{\text{limit}} = V_{\text{limit}} / I = 1 \text{ volt} / (0.015 \text{ Amps} * 4 \text{ SBE 38s}) = 17 \text{ ohms}$$

For 18 gauge wire, resistance is 0.0064 ohms/foot.

Therefore, maximum cable length is 17 ohms / 0.0064 ohms/foot = 2604 feet = 794 meters (cable length to SBE 38 furthest from power source).

Supplying Enough Power to SBE 38

Another consideration in determining maximum cable length is supplying enough power at the power source so that sufficient voltage is available, after the IR loss in the cable, to power the SBE 38.

Example 1 – For 18 gauge wire, what is maximum distance to transmit power to RS-232 SBE 38 if using 8.5 volt power source to supply power? Is this controlling factor for maximum cable length if wanting to transmit at 1200 baud?

SBE 38's input power specification is 8 – 15 volts. Therefore, a 0.5 volt IR drop (8.5 volts – 8 volts) would still provide enough power to SBE 38.

$V = IR$ 0.5 volts = (0.015 Amps) * (0.0064 ohms/foot * cable length) Cable length = 5208 ft = 1588 meters

Note that 1588 meters > 800 meters (maximum distance SBE 38 can transmit data at 1200 baud), so IR drop in power is not controlling factor for this example.

Example 2 – Same as above, but there are 4 SBE 38s powered from the same power supply.

$V = IR$ 0.5 volts = (0.015 Amps * 4 SBE 38s) * (0.0064 ohms/foot * cable length)

Cable length = 1302 ft = 397 meters (cable length to SBE 38 furthest from power source).

Note that 397 meters < 800 meters (maximum distance SBE 38 can transmit data at 1200 baud), so IR drop in power is controlling factor for this example. Using a higher voltage power supply or a different wire gauge (12 or 14 gauge) would provide sufficient power at SBE 38 to allow 800 meter cable length.

Command Descriptions

This section describes commands and provides sample outputs. See *Appendix IV: RS-232 Command Summary* for a summarized command list.

When entering commands:

- Input commands to the SBE 38 in upper or lower case letters and register commands by pressing the Enter key.
- The SBE 38 sends ? CMD if an invalid command is entered.
- If the system does not return an S> prompt after executing a command, press the Enter key to get the S> prompt.

Note:

If the voltage is below 6.5 volts, the following displays in response to **DS**:
WARNING: LOW BATTERY VOLTAGE!!

Status Command

DS Display status and setup parameters.
Equivalent to Status on Toolbar.
Description in example includes, where applicable, command used to modify parameter.

Example: (user input in bold).

```
S>DS
SBE 38 V 1.4 S/N = 0090 (firmware version, serial number)
NAVG=1 (number of A/D cycles to average for each sample [NAvg=])
Not sampling data (sampling status)
Automatically start sampling on power up (sampling start-up mode [AutoRun=])
Default interface is RS-232 (RS-232 or RS-485 interface [Interface=])
```

Setup Commands

Interface=x x=**232**: Set interface to RS-232.
x=**485**: Set interface to RS-485. See *Appendix III: RS-485 Interface* for all details.

Baud=x x= baud rate (1200, 2400, 4800, 9600).
Default 9600.

Format=x x=**C**: Output converted data (°C).
x=**R**: Output raw data (counts).

Digits=x x= number of digits (0 – 6) to right of decimal point for converted temperature (°C). Applicable only if **Format=C**.

NAvg=x x= number of A/D cycles to average per sample (1 – 127).
Time between samples (seconds)
= (0.133 * **NAvg**) + 0.339
(Time between samples for continuous sampling; minimum time required for each polled sample.)

AutoRun=x x=**N**: Wait for a command when power is applied.
x=**Y**: Start continuous sampling automatically when power is applied.

Note:

The SBE 38's baud (set with **Baud=**) must be the same as Seaterm's baud rate (set in Configure menu).

Notes:

- The SBE 38 transmits data **after** it has completed the previous sample and before it starts the next sample.
- For continuous sampling with an RS-485 interface, set **NAvg** ≥ 30. See *Appendix III: RS-485 Interface*.

Note:

After you send **AutoRun=Y**, to start sampling immediately:

- Turn power off and then on again, or
- Send **Go**.

Notes:

- To capture real-time data to a file, do this *before* starting sampling:
 - Click Toolbar's Capture button.
 - Enter desired file name in dialog box. *Capture* status displays in status bar at bottom of screen.
- If the SBE 38 is sampling data and the voltage is less than 6.5 volts for ten consecutive scans, the SBE 38 halts sampling and sets the status to `low battery`.

Note:

You may need to send **Stop** several times to get the SBE 38 to respond.

Sampling Commands

These commands are used to request data from the SBE 38.

For all sampling commands:

- Output format is determined by **Format=** and **Digits=**.
- Number of A/D cycles per sample is defined by **NAvg**.

Go	Start sampling data continuously, and transmit data real-time. Time between samples (seconds) $= (0.133 * \text{NAvg}) + 0.339$
Stop	Stop continuous sampling. Press Enter key to get <code>S></code> prompt before entering Stop .
TS	Take 1 sample and transmit data.
TH	Take 1 sample and hold data in SBE 38 buffer.
SH	Transmit data that was held in SBE 38 buffer.
SL	Transmit data from last sample from SBE 38 buffer.
SLT	Transmit data from last sample from SBE 38 buffer, and then take 1 new sample and hold data in buffer.

Calibration Coefficients Commands

DC	Display calibration coefficients. Equivalent to Coefficients on Toolbar.
-----------	---

Notes:

- Date shown is when calibration was performed. Calibration coefficients are initially factory-set and should agree with Calibration Certificate shipped with SBE 38.
- See individual Coefficient Commands below for definitions of the data in the example.

Example: Display coefficients for SBE 38 (user input in bold).

```
S>DC
SBE 38  V 1.4   S/N = 0090
Cal Date:    08-apr-96
A0 = -9.420702e-05
A1 =  2.937924e-04
A2 = -3.739471e-06
A3 =  1.909551e-07
Slope = 1.000000
Offset = 0.0000
```

The individual Coefficient Commands listed below modify a particular coefficient or date:

T CalDate= S	S =Temperature calibration date
A0 = F	F =Temperature A0
A1 = F	F =Temperature A1
A2 = F	F =Temperature A2
A3 = F	F =Temperature A3
Slope = F	F =Temperature slope (default 1.0)
Offset = F	F =Temperature offset (°C) (default 0.0)

Note:

F = floating point number
S = string with no spaces

Data Formats

Notes:

- Each line of output is followed by a carriage return and line feed.
- For converted data, leading zeros for temperature output are suppressed, except for one zero to the left of the decimal point (for example, 0.1034).
- See *Appendix III: RS-485 Interface* for data output format for an SBE 38 with RS-485 interface.

Converted Data (Format=C)

ttt.ttt

where:

t = temperature (degrees Celsius, ITS-90)

Number of digits to right of decimal point is defined by **Digits=**.

Raw Data (Format=R)

nnnnnn.n

where:

n= counts

Deployment

CAUTIONS:

- **Do not use WD-40** or other petroleum-based lubricants, as they will damage the connectors.
- For wet-pluggable MCBH connectors: **Silicone lubricants in a spray can** may contain ketones, esters, ethers, alcohols, or glycols in their propellant. **Do not use these sprays, as they will damage the connector.**

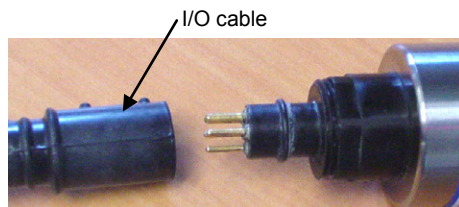

1. Install the I/O cable:
 - A. Lightly lubricate the inside of the cable connector with silicone grease (DC-4 or equivalent).
 - B. **XSG Connector** (shown in photo) - Install the cable connector, aligning the raised bump on the side of the connector with the large pin (pin 1 - ground) on the SBE 38. Remove any trapped air by *burping* or gently squeezing the connector near the top and moving your fingers toward the end cap. **OR**
MCBH Connector – Install the cable connector, aligning the pins.
 - C. Place the locking sleeve over the connector. Tighten the locking sleeve finger tight only. **Do not overtighten the locking sleeve and do not use a wrench or pliers.**
2. Mount the SBE 38.
3. Verify that the hardware and external fittings are secure.
4. Use **one** of the following sequences to start sampling:
 - If **AutoRun=N**: Send **Go** to start sampling continuously now, or **TS** or **TH** to take a single sample.
 - If **AutoRun=Y**: Apply power to start sampling continuously now.
5. Deploy the SBE 38.

Recovery

WARNING!

If the SBE 38 stops working while underwater, is unresponsive to commands, or shows other signs of flooding or damage, carefully secure it away from people until you have determined that abnormal internal pressure does not exist or has been relieved. Pressure housings may flood under pressure due to dirty or damaged o-rings, or other failed seals. When a sealed pressure housing floods at great depths and is subsequently raised to the surface, water may be trapped at the pressure at which it entered the housing, presenting a danger if the housing is opened before relieving the internal pressure. Instances of such flooding are rare. However, a housing that floods at 5000 meters depth holds an internal pressure of more than 7000 psia, and has the potential to eject the end cap with lethal force. A housing that floods at 50 meters holds an internal pressure of more than 85 psia; this force could still cause injury.

If you suspect the SBE 38 is flooded, point it in a safe direction away from people, and loosen the bulkhead connector very slowly, at least 1 turn. This opens an o-ring seal under the connector. Look for signs of internal pressure (hissing or water leak). If internal pressure is detected, let it bleed off slowly past the connector o-ring. Then, you can safely remove the end cap.

1. Use **one** of the following sequences to stop sampling:
 - Press Enter key to get S> prompt, and then send **Stop** to stop sampling continuously. **OR**
 - Remove power.
2. Rinse the SBE 38 with fresh water, and dry thoroughly.

Section 5: Routine Maintenance and Calibration

This section reviews corrosion precautions, connector mating and maintenance, O-ring maintenance, and sensor calibration. The SBE 38's accuracy is sustained by the care and calibration of the sensor and by establishing proper handling practices.

Corrosion Precautions

All exposed materials are titanium or plastic. No corrosion precautions are required, but direct electrical connection of the SBE 38 housing to mooring or other dissimilar metal hardware should be avoided. Rinse the SBE 38 with fresh water after use and prior to storage.

Connector Mating and Maintenance

Note:

See *Application Note 57: Connector Care and Cable Installation*.

Clean and inspect the connectors, cable, and dummy plug before every deployment and as part of your yearly equipment maintenance. Inspect connectors that are unmated for signs of corrosion product around the pins, and for cuts, nicks or other flaws that may compromise the seal.

CAUTIONS:

- **Do not use WD-40** or other petroleum-based lubricants, as they will damage the connectors.
- For wet-pluggable MCBH connectors: **Silicone lubricants in a spray can** may contain ketones, esters, ethers, alcohols, or glycols in their propellant. **Do not use these sprays, as they will damage the connector.**

When remating:

1. Lightly lubricate the inside of the cable connector with silicone grease (DC-4 or equivalent).
2. **XSG Connector** - Install the cable connector, aligning the raised bump on the side of the plug/cable connector with the large pin (pin 1 - ground) on the SBE 38. Remove any trapped air by *burping* or gently squeezing the connector near the top and moving your fingers toward the end cap. **OR MCBH Connector** - Install the cable connector, aligning the pins.
3. Place the locking sleeve over the cable connector. Tighten the locking sleeve finger tight only. **Do not overtighten the locking sleeve and do not use a wrench or pliers.**

Verify that a cable is installed on the SBE 38 before deployment.

O-Ring Maintenance

Note:

For details on recommended practices for cleaning, handling, lubricating, and installing O-rings, see the *Basic Maintenance of Sea-Bird Equipment* module in the Sea-Bird training materials on our website.

Recommended inspection and replacement schedule for O-rings that are not normally disturbed (for example, on the electronics end cap) - approximately every 3 to 5 years.

Remove any water from the O-rings and mating surfaces in the housing with a lint-free cloth or tissue. Inspect O-rings and mating surfaces for dirt, nicks, and cuts. Clean or replace as necessary. Apply a light coat of O-ring lubricant (Parker Super O Lube) to O-rings and mating surfaces.

CAUTION:

Do not use Parker O-Lube, which is petroleum based; use only Super O-Lube.

Sensor Calibration

Sea-Bird sensors are calibrated by subjecting them to known physical conditions and measuring the sensor responses. Coefficients are then computed, which may be used with appropriate algorithms to obtain engineering units. The temperature sensor on the SBE 38 is supplied fully calibrated, with coefficients printed on the Calibration Certificate (see back of manual). These coefficients have been stored in the SBE 38's EEPROM.

We recommend that the SBE 38 be returned to Sea-Bird for calibration.

The primary source of temperature sensor calibration drift is the aging of the thermistor element. Sensor drift is not substantially dependent upon the environmental conditions of use, and — unlike platinum or copper elements — the thermistor is insensitive to shock.

Sea-Bird's Calibration Methodology

The SBE 38 is calibrated in Sea-Bird's state-of-the-art calibration laboratory, which maintains primary temperature standards (water triple point [TPW] and gallium melting point [GaMP] cells), ITS-90 certified and standards-grade platinum resistance thermometers, and a low-gradient temperature bath.

Temperature is computed using the Steinhart-Hart polynomial for thermistors (Steinhart and Hart, 1968; Bennett, 1972), which is based on thermistor physics. The equation characterizes the non-linear temperature versus resistance response of the sensor. Note that thermistors require individualized coefficients to the Steinhart-Hart equation, because the thermistor material is an individualized mix of dopants:

$$t_{90} = \left[\frac{1.0}{a_0 + a_1 * [\ln(n)] + a_2 * [\ln^2(n)] + a_3 * [\ln^3(n)]} - 273.15 \right] * \text{Slope} + \text{Offset } [^{\circ}\text{C}]$$

where

n = SBE 38 raw output (counts).

Glossary

PCB – Printed Circuit Board.

SBE 38 – High-accuracy digital oceanographic thermometer.

SBE Data Processing – Sea-Bird’s Windows data processing software, which calculates and plots measured and derived variables. SBE Data Processing can be used to view and process the entire data stream, including data from the SBE 38, *when the SBE 38 is integrated with one of the following:*

- SBE 21 or 45 thermosalinograph,
- SBE 16*plus*, 16*plus* V2, or 16*plus* -IM V2 SeaCAT C-T Recorder
- SBE 19*plus* V2 SeaCAT CTD Profiler
- SBE 25*plus* Sealogger CTD

Scan – One data sample.

Seasave V7 – Sea-Bird’s Windows software used to acquire, convert, and display real-time or archived raw data. Seasave V7 can be used to view and process the entire data stream, including data from the SBE 38, *when the SBE 38 is integrated with one of the following:*

- SBE 21 or 45 thermosalinograph,
- SBE 16*plus*, 16*plus* V2, or 16*plus* -IM V2 C-T Recorder
- SBE 19*plus* V2 CTD Profiler
- SBE 25*plus* Sealogger CTD (Seasave can acquire SBE 38 data with this CTD, but SBE 38 data cannot be viewed in real-time)

Seasoft V2 – Sea-Bird’s complete Windows software package, which includes software for communication, real-time data acquisition, and data analysis and display. Seasoft V2 includes *Seaterm*, *SeatermAF*, *SeatermV2*, *Seasave V7*, *SBE Data Processing*, and *Plot39*.

Seaterm – Sea-Bird’s Windows terminal program used to communicate with the SBE 38.

Super O-Lube – Silicone lubricant used to lubricate O-rings and O-ring mating surfaces. Super O-Lube can be ordered from Sea-Bird, but should also be available locally from distributors. Super O-Lube is manufactured by Parker Hannifin (www.parker.com/ead/cm2.asp?cmid=3956).

Note:

All Sea-Bird software listed was designed to work with a computer running Windows XP service pack 2 or later, Windows Vista, or Windows 7 (32-bit or 64-bit).

CAUTION:

Do not use Parker O-Lube, which is petroleum based; use only Super O-Lube.

Appendix I: Functional Description

Sensor Interface

Temperature is acquired by applying an AC excitation to a hermetically sealed VISHAY reference resistor and an ultra-stable aged thermistor with a drift rate of less than 0.002°C per year. A 24-bit A/D converter digitizes the outputs of the reference resistor and thermistor. AC excitation and ratiometric comparison using a common processing channel avoids errors caused by parasitic thermocouples, offset voltages, leakage currents, and reference errors. Maximum power dissipated in the thermistor is 0.5 microwatts, and contributes less than 200 µK of overheat error.

A raw count (ratio) is related to resistance measurements:

$$\text{raw counts} = 1048576 * (NT) / (NR)$$

where

NR = output from reference resistor

NT = thermistor output

The SBE 38's output is computed from the raw count and the calibration coefficients that are stored in EEPROM.

The number of acquisition cycles (raw counts) averaged per measurement is user-programmable (**NAvg**; see *Section 4: Deploying and Operating RS-232 SBE 38*). Increasing the number of cycles per measurement increases the time to acquire the measurement and the interval between measurements, while reducing the RMS temperature noise from the sensor. The interval between measurements is:

$$\text{interval [seconds]} = (0.133 * \text{NAvg}) + 0.339$$

where

NAvg = number of acquisition cycles per measurement

The SBE 38 transmits data **after** it has completed the previous sample and before it starts the next sample.

Time to transmit data = (number of characters * 10 bits/character) / baud rate

where

number of characters is dependent on the output format. Include the decimal point when counting characters; add 2 to the number of characters output, to account for the carriage return and line feed at the end of each scan.

Settings

Calibration coefficients and setup parameters (**Baud**, **NAvg**, **Interface**, etc.) are written to EEPROM and are non-volatile. These settings do not change if power is removed.

Appendix II: Electronics Disassembly/Reassembly

Note:

Before delivery, a desiccant bag is placed in the housing, and the electronics chamber is filled with dry Argon gas. These measures help prevent condensation.

To ensure proper functioning:

1. **Install a new desiccant bag each time you open the housing.** If a new bag is not available, see *Application Note 71: Desiccant Use and Regeneration (drying)*.
2. If possible, dry gas backfill each time you open the housing. If you cannot, wait at least 24 hours before redeploying, to allow the desiccant to remove any moisture from the chamber.

CAUTION:

Do not use Parker O-Lube, which is petroleum based; use only Super O-Lube.

1. Remove the titanium end cap and electronics from the housing as follows:
 - A. Wipe the outside of the end cap and housing dry, being careful to remove any water at the seam between them.
 - B. Unscrew the end cap.
 - C. Pull the end cap and attached electronics out of the housing. Note that the PCB is electrically connected to the I/O connector.
 - D. Remove any water from the end cap O-ring and mating surfaces inside the housing with a lint-free cloth or tissue.
 - E. Be careful to protect the O-ring from damage or contamination.
2. Reinstall the end cap and electronics in the housing as follows:
 - A. Remove any water from the O-ring and mating surfaces in the housing with a lint-free cloth or tissue. Inspect the O-ring and mating surfaces for dirt, nicks, and cuts. Clean as necessary. Apply a light coat of O-ring lubricant (Parker Super O Lube) to O-ring and mating surfaces.
 - B. Carefully fit the electronics into the housing.
 - C. Screw the end cap into the housing.

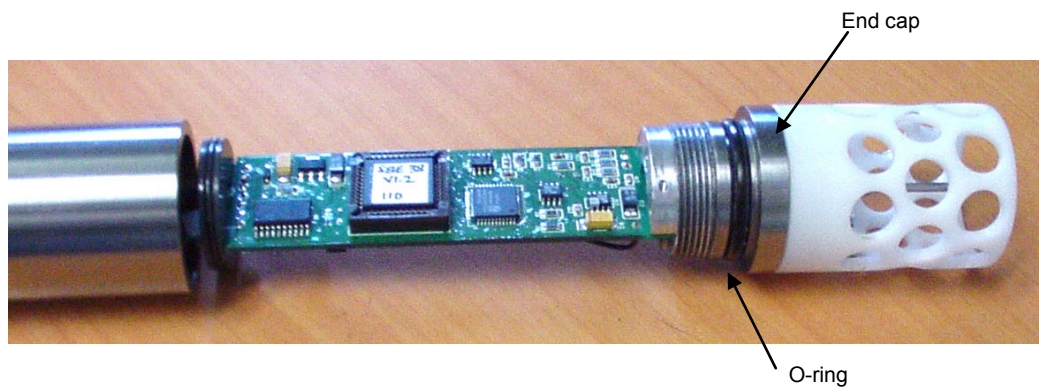

Appendix III: RS-485 Interface

Operation Description

Notes:

- **IDReq=Y** does **not** require a **#ii** prefix. **IDReq=N** **does** require a **#ii** prefix (**#iiIDReq=N**).
- For customers using their own terminal program software: Terminate all commands with CR only, not CRLF.
- See *Application Note 56: Interfacing to RS-485 Sensors* for information on RS-485 adapters and converters.

Commands can be directed to one SBE 38 or globally to all SBE 38s. If **IDReq=Y**, a command prefix (**#ii**) is used to direct commands to an SBE 38 with the same ID (**ii = ID**). Global commands do not use a prefix, regardless of the setting for **IDReq=**, and are recognized by all SBE 38s attached to the RS-485 interface.

An example follows for a system with two SBE 38s (IDs 01 and 02) online. Note that the SBE 38's response to each command is not shown in the example. Review the commands described in *Command Descriptions* and the example below before setting up your system.

Example: Wake up all SBE 38s. Set up all SBE 38s to average 40 measurements per sample and output converted data with 3 digits to the right of the decimal place. Command all SBE 38s to take a sample and hold data in buffer, and then command each SBE 38 to transmit data from buffer. Repeat sampling sequence a number of times. (user input in bold)

(Apply power and click Connect on Toolbar to wake up all SBE 38s.)

```
S>IDREQ=Y           (command to require ID prefix)
S>#01NAVG=40       (set number of measurements per sample to 40 for SBE 38 with ID=01)
S>#02NAVG=40       (set number of measurements per sample to 40 for SBE 38 with ID=02)
S>#01FORMAT=C     (set output format to converted data for SBE 38 with ID=01)
S>#02FORMAT=C     (set output format to converted data for SBE 38 with ID=02)
S>#01DIGITS=3     (set number of digits to right of decimal point to 3 for SBE 38 with ID=01)
S>#02DIGITS=3     (set number of digits to right of decimal point to 3 for SBE 38 with ID=02)
S>#01DS           (verify setup with status command for SBE 38 with ID=01)
S>#02DS           (verify setup with status command for SBE 38 with ID=02)
S>GDATA           (global command to all SBE 38s to take sample and hold data in buffer)
S>DATA01          (get data from buffer of SBE 38 with ID=01)
S>DATA02          (get data from buffer of SBE 38 with ID=02)
```

(Repeat **GDATA** through **DATA02** as desired)

Command Descriptions

Note:

For reliable operation, all commands **may** need to be preceded with two @ characters to clear the buffers.

Example (status command for SBE 38 with ID=01):

S>@@#01DS

Note:

GData and **AData** perform the same function in the SBE 38. Both are included here to provide compatibility with RS-485 MicroCATs.

Note:

IDReq=Y does **not** require a #ii prefix. **IDReq=N** does require a #ii prefix (#iiIDReq=N).

RS-485 Commands

Global Commands

Global commands are recognized by **all** SBE 38s attached to the RS-485 interface.

TxDelay=x x= delay after SBE 38 transmits a reply until SBE 38 transmitter is disabled (1 – 500 milliseconds). Default 25 milliseconds.

RxDelay=x x= delay after SBE 38 receives a command until SBE 38 transmitter is enabled (1 – 500 milliseconds). Default 25 milliseconds.

GData Command **all** SBE 38s to take 1 sample and hold data in SBE 38 buffer until receiving:
- **DATAii**;
- **SH, SL, or SLT** (if #iiIDReq=N); or
- **#iiSH, #iiSL, or #iiSLT** (if IDReq=Y).

AData Command **all** SBE 38s to take 1 sample and hold data in SBE 38 buffer until receiving:
- **DATAii**;
- **SH, SL, or SLT** (if #iiIDReq=N); or
- **#iiSH, #iiSL, or #iiSLT** (if IDReq=Y).

Get Data Command

DATAii Get data obtained with **GData** or **AData** from SBE 38 with ID = ii (ii = 0 -99).

ID Required Command

IDReq=Y Precede commands to individual SBE 38s with #ii, where ii= ID (ii = 0 -99). Use this setting for systems with multiple RS-485 instruments on 1 pair of wires. Note that the use of a prefix does not apply to Global, Get Data, or ID commands.

#iiIDReq=N Do not precede commands to individual SBE 38s with #ii. Use this setting for systems with only 1 SBE 38.

Example 1: Multiple RS-485 instruments on 1 pair of wires (user input in bold)

```
S>IDREQ=Y (command to require ID prefix)
S>#01NAVG=40 (set number of A/D cycles to average for SBE 38 with ID=01)
S>#02NAVG=40 (set number of A/D cycles to average for SBE 38 with ID=02)
S>#01DS (verify setup with status command for SBE 38 with ID=01)
S>#02DS (verify setup with status command for SBE 38 with ID=02)
```

Example 2: Only 1 SBE 38 on 1 pair of wires, with ID=01 (user input in bold)

```
S>#01IDREQ=N (command to not require ID prefix; note that #ii prefix is required)
S>NAVG=40 (set number of A/D cycles to average for SBE 38, no ID required as part of command)
S>DS (verify setup with status command for SBE 38, no ID required as part of command)
```

ID Commands

Only one SBE 38 can be online when sending these commands.

ID? Display SBE 38 ID (ID = ii, where ii= 0-99) and whether ID is required as a prefix for commands to individual SBE 38s (see **IDReq=**).

***ID=ii** Set SBE 38 ID to ii, where ii= 0-99. ***ID=** must be sent twice, because the SBE 38 requests verification. **If more than one RS-485 instrument is online when sending this command, all instruments online will be set to same ID.**

All Other Commands

All other commands (status, setup, sampling, and coefficients) are listed in *Section 4: Deploying and Operating RS-232 SBE 38* and in *Appendix IV: RS-232 Command Summary*.

Notes on use of these commands for an SBE 38 with RS-485 interface:

Note:

IDReq=Y does not require a **#ii** prefix.
IDReq=N does require a **#ii** prefix (**#iiIDReq=N**).

- Effect of **IDReq=**:
If **IDReq=Y**, precede these commands with **#ii** (ii = 0 – 99) to direct a command to a particular SBE 38.
If **#iiIDReq=N**, do not precede these commands with **#ii**. This setting works only for a system with one SBE 38.
- The RS-485 interface cannot accommodate multiple instruments transmitting real-time data at the same time. Therefore, do not set **AutoRun=Y** (start sampling continuously when power is applied) for a system with more than one RS-485 instrument on a pair of wires. Similarly, do not attempt to send **Go** to multiple SBE 38s on a pair of wires, as the system cannot transmit a command to one instrument while another instrument is transmitting real-time data.
- **If planning to sample continuously:** If **AutoRun=Y** (sample continuously when power is applied) or using the **Go** command to start sampling continuously, set **NAvg= (A/D cycles to average per sample) to a value greater than or equal to 30.**

Data Formats**Notes:**

- Each line of output is followed by a carriage return and line feed.
- For converted data, leading zeros for temperature output are suppressed, except for one zero to the left of the decimal point (for example, 0.1034).

Converted Data (Format=C)

Output from continuous sampling: ttt.ttt

Output from DATAii, #iiTS, TS, #iiSH, SH, #iiSL, SL, #iiSLT, or SLT:

ii, sssss, ttt.ttt

where:

- t = temperature (°C, ITS-90)
(number of digits to right of decimal point is defined by **Digits=**)
- ii = ID (0 – 99)
- sssss = SBE 38 serial number

Raw Data (Format=R)

nnnnnn.n

where:

- n = counts

Wiring

Note:

See *Power and Cable Length* in *Section 4: Deploying and Operating RS-232 SBE 38* for cable limitations related to the supply of power.

When configured with the RS-485 interface, the SBE 38 can transmit data over up to 1200 meters of 26 AWG twisted pair wire cable.

The MAX1483 transceivers used in the SBE 38 are designed for bi-directional data communications on multi-point bus transmission lines. To minimize reflections, terminate the line at both ends in its characteristic impedance. Also, keep stub lengths off the main line as short as possible (although the slew-rate-limited MAX1483 is more tolerant of imperfect termination than standard RS-485 ICs).

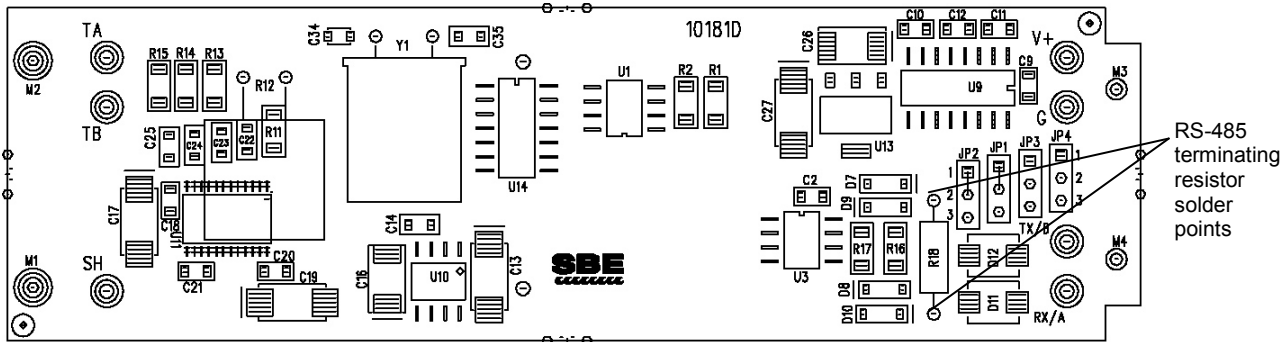

Conversion of RS-232 to RS-485 or RS-485 to RS-232

Notes:

- See *Appendix II: Electronics Disassembly / Reassembly* to access the PCB.
- Send **Interface=232** or **Interface=485** to program the SBE 38 to match the wired configuration.

Sea-Bird supplies the SBE 38 with the correct jumper settings on the Printed Circuit Board (PCB) for your ordered configuration (RS-232 or RS-485). If desired, you can modify the jumper settings to change the configuration:

Wiring: connect -

- Pin 2 (black) to RS-232 RX / RS-485 'A'
- Pin 3 (green) to RS-232 TX / RS-485 'B'

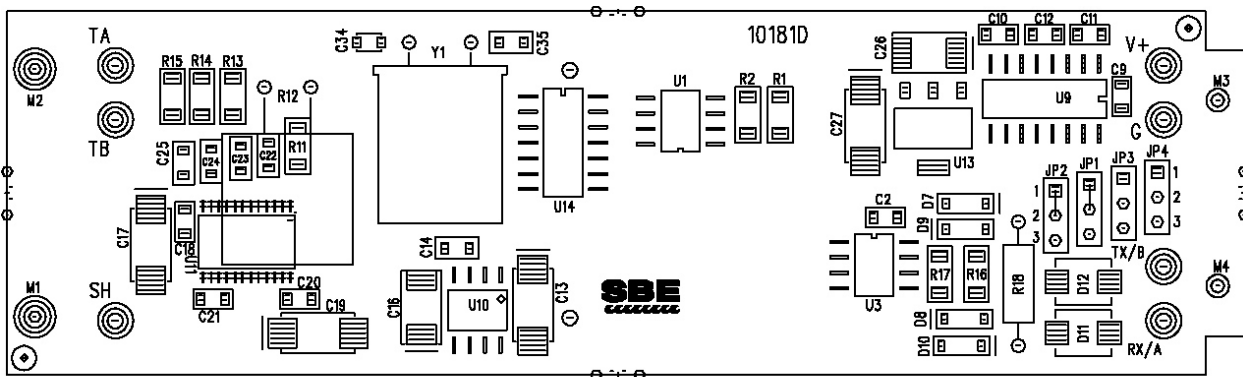

JUMPER CONFIGURATION: TRANSMIT/RECEIVE

JP1/JP2 NOTE: PCB TRACE CONNECTION ACROSS PINS 1-2 MUST BE CUT BEFORE JUMPING PINS 2-3
X = DON'T CARE

	JP1	JP2	JP3	JP4
RS-232	1-2	1-2	1-2	1-2
RS-485	X	X	2-3	2-3

Appendix IV: RS-232 Command Summary

Notes:

- See *Command Descriptions* in Section 4: *Deploying and Operating RS-232 SBE 38* for detailed information and examples.
- See *Appendix III: RS-485 Interface* for details on deploying and operating an SBE 38 with RS-485 interface.

CATEGORY	COMMAND	DESCRIPTION
Status	DS	Display status and setup parameters.
Setup	Interface=x	x=232 : RS-232 interface. x=485 : RS-485 interface.
	Baud=x	x = baud rate (1200, 2400, 4800, 9600). Default 9600.
	Format=x	x=C : Output converted data (°C). x=R : Output raw data (counts).
	Digits=x	x = number of digits (0 – 6) to right of decimal point for converted temperature (°C). Applicable only if Format=C .
	NAvg=x	x = A/D cycles to average per sample (1 – 127).
	AutoRun=x	x=N : Wait for a command when power applied. x=Y : Start continuous sampling automatically when power applied.
Sampling	Go	Start continuous sampling now.
	Stop	Stop continuous sampling. Press Enter key to get S> prompt before entering Stop .
	TS	Take 1 sample and transmit data.
	TH	Take 1 sample and hold data in buffer.
	SH	Transmit data that was held in buffer.
	SL	Transmit data from last sample from buffer.
Coefficients (F=floating point number; S=string with no spaces) Date shown is when calibration was performed. Calibration coefficients are initially factory-set and should agree with Calibration Certificate shipped with SBE 38.	DC	Display calibration coefficients; all coefficients and dates listed below are included. Use individual commands below to modify a particular coefficient or date.
	CalDate=S	S =Temperature calibration date.
	A0=F	F =Temperature A0.
	A1=F	F =Temperature A1.
	A2=F	F =Temperature A2.
	A3=F	F =Temperature A3.
	Slope=F	F =Temperature slope (default 1.0).
Offset=F	F =Temperature offset (default 0.0).	

Appendix V: Replacement Parts

Part Number	Part	Application Description	Quantity in SBE 38
231361	Plastic temperature sensor guard	Screws to end cap to protect temperature sensor	1
30931	O-ring, Parker 2-214 N674-70	Placed in end cap groove for watertight seal	1
801376	4-pin RMG-4FS to 9-pin DB-9S I/O cable with battery snap, 2.4 m (8 ft) long	From SBE 38 (XSG) to computer	1
801263	4-pin MCIL-4FS to 9-pin DB-9S I/O cable with battery snap, 2.4 m (8 ft) long	From SBE 38 (wet-pluggable) to computer	1
17046.1	4-pin RMG-4SD-LP dummy plug with locking sleeve	For SBE 38 (XSG) connector	1
171398.1	4-pin MCIL-4FS dummy plug with locking sleeve	For SBE 38 (wet-pluggable) connector	1

Appendix VI: Manual Revision History

Manual Version	Date	Description
006	03/03	Major rewrite: Remove DOS terminal program information and replace with Seaterm, add wet-pluggable connector option, correct calibration range to -1 to +32 (from -1 to +35 in old manual), correct calibration equation information.
007	03/04	<ul style="list-style-type: none"> • Correct available bauds in command summary (remove 19200 & 3840). • Add power vs cable length information. • Update cable list to 9-pin cable. • Update Seaterm screens.
008	01/05	<ul style="list-style-type: none"> • Firmware 1.3 added 3 commands: slope= (default 1.0), offset=(default 0). • Temperature calculation has slope & offset included in equation: t = t * slope + offset
009	05/06	<ul style="list-style-type: none"> • Remove high range temperature calibration option (removed from price list). • Update wet-pluggable connector information. • Add more information to Recovery Warning.
010	01/09	<ul style="list-style-type: none"> • PCB changed, connections and jumpers changed for conversion between RS-232 & RS-485. • Update for V2 SeaCATs –integration with 16plus V2, 16plus-IM V2, 19plus V2. • Add information about compatibility with Vista. • Remove information about DOS software. • Update connector maintenance information for consistency with application note 57.
011	04/09	<ul style="list-style-type: none"> • Change spec for current to 15 mA for RS-232 version. Also change current for RS-485 to 10 mA.
012	01/10	<ul style="list-style-type: none"> • Change Seasoft-Win32 to Seasoft V2, update file name to SeasoftV2_date.exe. • Add information required for CE certification, and add CE mark. • Update SBE address.
013	03/11	<ul style="list-style-type: none"> • Add more information on RS-485 operation: <ul style="list-style-type: none"> - Set NAvg \geq 30 for continuous sampling (using Go to start sampling, or if AutoRun=Y). - IDReq=Y does not require #ii prefix, but IDReq=N does require #ii prefix (#iiIDReq=N). - For customers using their own terminal program: terminate commands with CR (not CRLF) • Add information about compatibility with Windows 7
014	04/13	<ul style="list-style-type: none"> • Add Declaration of Conformity. • Add cable wiring drawing. • Update software compatibility information. • Add information on use with SBE 25plus CTD. • Add reference to Application Note 56 for information onRS-485 adapters and converters. • Fix typos.
015	02/15	<ul style="list-style-type: none"> • Update Declaration of Conformity. • Add information on O-ring maintenance. • Add caution regarding using spray can lubricants on MCBH connectors. • Add caution regarding using Parker Super O Lube, not Parker O Lube (which is petroleum based). • Remove <i>standard</i> and <i>optional</i> language related to SBE 38 features. • Update language on where to find software on website. • Switch to Sea-Bird Scientific cover.

Index

B

Baud rate · 16, 18

C

Cable length · 16
 Cables · 9
 Calibration · 23
 Calibration coefficients · 19
 CE certification · 3
 Command summary · 31
 Commands
 baud · 18
 calibration coefficients · 19
 data format · 18
 descriptions · 18
 get data · 28
 global · 28
 ID · 28, 29
 ID required · 28
 RS-485 · 28
 sampling · 19
 setup · 18
 status · 18
 Communication defaults · 12
 Connector · 9, 22
 Continuous sampling · 15
 Corrosion precautions · 22

D

Data acquisition · 10
 Data format · 18, 20, 29
 Data processing · 10
 Declaration of Conformity · 3
 Deployment
 installation · 20
 preparing for · 10
 Description · 7
 Desiccant · 26
 Dimensions · 9
 Disassembly / reassembly · 26

E

Electronics · 26

F

Flooded instrument · 21
 Format · 18
 data · 20, 29
 Functional description · 25

G

Get data · 28
 Global commands · 28
 Glossary · 24

I

ID commands · 28, 29

L

Limited liability statement · 2

M

Maintenance · 22
 Manual revision history · 33
 Modes · *See* Sampling modes

O

Operation description · 27
 O-ring
 maintenance · 22

P

Parts
 replacement · 32
 Polled sampling · 14
 Power · 16

Q

Quick start · 5

R

Real-time data acquisition · 10
 Recovery · 21
 Replacement parts · 32
 Revision history · 33
 RS-232 · 14, 18
 conversion to RS-485 · 30
 RS-485 · 18, 27
 conversion to RS-232 · 30
 wiring · 30
 RS-485 commands · 28

S

Sampling · 19
 Sampling modes · 14
 continuous · 15
 polled · 14
 SBE Data Processing · 7, 10
 Seasave · 7, 10
 Seasoft · 7, 10
 Seaterm · 7, 10, 11
 main screen · 11
 toolbar buttons · 12
 Sensor · 8
 Serial interface · 18, 27
 Settings · 25
 Setup commands · 18
 Software · 7
 installation · 10
 Specifications · 8
 Status commands · 18
 System description · 7

T

Terminal program · 10
 Testing · 10
 Thermistor · 25

U

Unpacking SBE 38 · 6

V

Versions · 33

W

Wiring · 9